

Customer Code: _____

DATASHEET

DAPU P/N : **O55A-A369-10.00MHz**

Customer P/N: _____

| DAPU | | | Customer Approval |
|------------------|---------|----------|------------------------|
| Drew | Audited | Approved | Stamp, please! Thanks! |
| | | | |
| Date: 2017.04.06 | | | |

Guangdong Dapu Telecom Technology Co.,Ltd

Bldg13-16,.N.Ind.Zone,SSL Industry Park, Dongguan City, Guangdong Province, China

TEL: 0086-0769-88010888 FAX: 0086-0769-81800098



Table of amendment

| Version | Revision contents | Prepared by | Revised date |
|---------|-------------------|--------------|--------------|
| 1.0 | The first issued | <i>Amway</i> | 2017.04.06 |
| | | | |
| | | | |
| | | | |
| | | | |
| | | | |
| | | | |
| | | | |
| | | | |
| | | | |
| | | | |
| | | | |
| | | | |
| | | | |
| | | | |
| | | | |
| | | | |
| | | | |
| | | | |
| | | | |
| | | | |



1. Electrical Parameters

| MODEL: O55A-A369-10.00MHz | | | | | | |
|---------------------------|---|------------|------|-------|------------------|--|
| Item | Description | Parameters | | | Unit | Test Condition |
| | | Min. | Typ. | Max. | | |
| Output | Frequency | 10.00 | | | MHz | |
| | Output Waveform | HCMOS | | | | |
| | Output Low Voltage | | | 0.4 | V | $V_{cc}=13.0V, O_{load}=15pF$ |
| | Output High Voltage | 2.7 | | | V | $V_{cc}=13.0V, O_{load}=15pF$ |
| | Duty Cycle | 45 | 50 | 55 | % | @50% |
| | Rise / Fall Time (10%~90%) | | 2 | 3 | ns | @25°C |
| | Load | 15 | | | pF | |
| Frequency Stabilities | Frequency Tolerance vs. Operating Temperature Range | -0.01 | | +0.01 | $\times 10^{-9}$ | T_A varied from -20°C to 70°C, measurement referenced to frequency observed with $f_{ref}=(f_{max}+f_{min})/2, V_{cc}=13.0V, O_{load}=15pF$, temperature variable speed less than 2°C per minute. |
| | Initial Frequency Tolerance | -0.05 | | +0.05 | $\times 10^{-6}$ | Measurement referenced to frequency observed with $T_A=25^\circ C, V_{cc}=13.0V$, and after 15 minutes of operation, within 30 days after ex-works. |
| | Frequency Tolerance vs. Supply Voltage | -0.01 | | +0.01 | $\times 10^{-9}$ | measurement referenced to frequency observed $T_A=25^\circ C, V_{cc}$ varied from 12.35V to 13.65V and $O_{Load}=15pF$. |
| | Frequency Tolerance vs. Load | -0.01 | | +0.01 | $\times 10^{-9}$ | 5% load change measurement referenced to frequency observed with $T_A=25^\circ C, V_{cc}=13.0V$, and $O_{Load}=15pF$. |
| | Short-Term Stability : Allan Variance | | | 0.005 | $\times 10^{-9}$ | Temperature stability, no EMI\EMC or other interference, test after power for 1hour ref. to 25°C; 1s, using PN9000 equipment. |
| | Aging Tolerance Per Day | -0.05 | | +0.05 | $\times 10^{-9}$ | V_{cc}, T_A constant measurement referenced to frequency observed with $T_A=25^\circ C, V_{cc}=13.0V$, and after 30 days of operation. |
| | Aging Tolerance 1 Year | -0.01 | | +0.01 | $\times 10^{-6}$ | |
| | Stratum type II compliant per G.812 teleconcordia | | | | | |
| Power Supply | Supply Voltage | 12.35 | 13.0 | 13.65 | V | |
| | Steady Consumption | | | 500 | mA | @25°C |
| | Warm up current | | | 1100 | mA | |



| | | | | | | |
|--------------------------|--|---|------|------|--------|--------|
| Phase Noise | Phase Noise | | -130 | -120 | dBc/Hz | 10Hz |
| | | | -145 | -135 | | 100Hz |
| | | | -150 | -145 | | 1KHz |
| | | | -155 | -150 | | 10KHz |
| | | | -155 | -150 | | 100KHz |
| | | | -155 | -150 | | 1MHz |
| Environmental Conditions | Operable Temperature | -40 | | +85 | °C | |
| | Storage Temperature | -55 | | +105 | °C | |
| | ESD Level | Human Body Model, class2: 2000V to 4000V; ANSI/ESDA/JEDEC JS-001-2010. | | | | |
| | | Machine Model, class B: 200V to 400V; ANSI/ESDA/JEDEC JS-001-2010. | | | | |
| | Moisture Sensitivity Level | Not humidity sensitive. | | | | |
| | Vibration | Test Condition: 0.75mm ;acceleration:10g;10Hz~500Hz, one cycle per 30 min, test 2 hour. (3 times for each 3 directions X , Y , Z), IEC 68-2-06 Test Fc. | | | | |
| Shock | 50g; 11ms; half sine wave (3 times for each 3 directions X ,Y, Z),IEC 68-2-27 Test Ea/Severity 50A. | | | | | |
| Full Package Storage | Relative humidity (%) | 20%~70% | | | | |
| | Temperature (°C) | -10~35°C | | | | |



2. Mechanical Structure (mm)

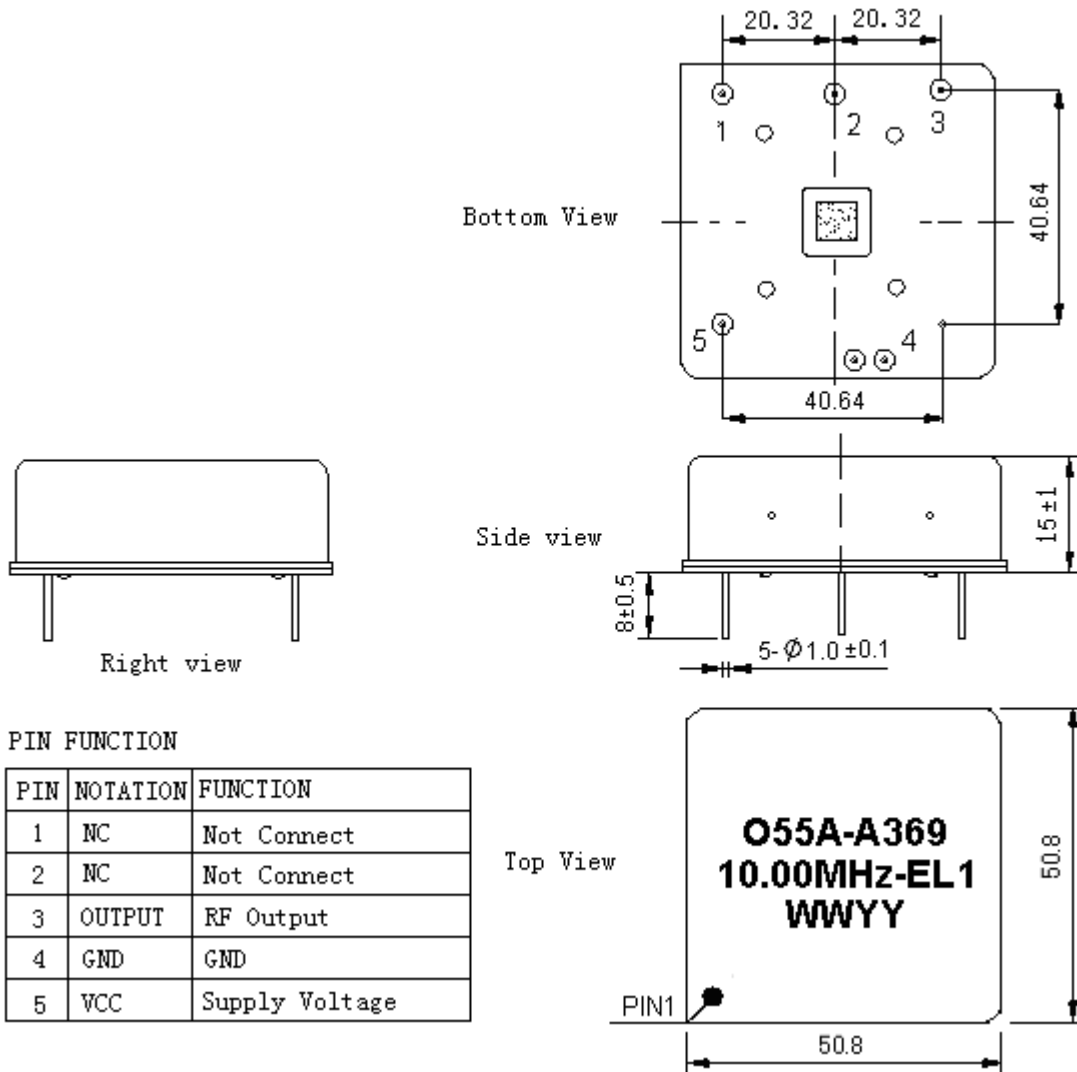

Note1: Tolerance ±0.2mm without mark

Note2: The ww representative: week
The yy representative: year

Note3: Referential weight 56.1g

Note4: NC is not connect



3. Test Circuit

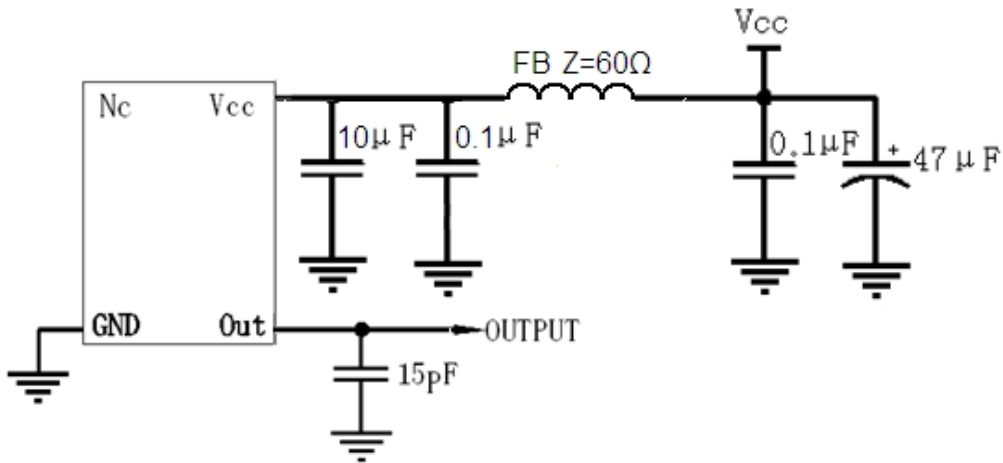

4. Reflow Soldering Curve (RoHS)

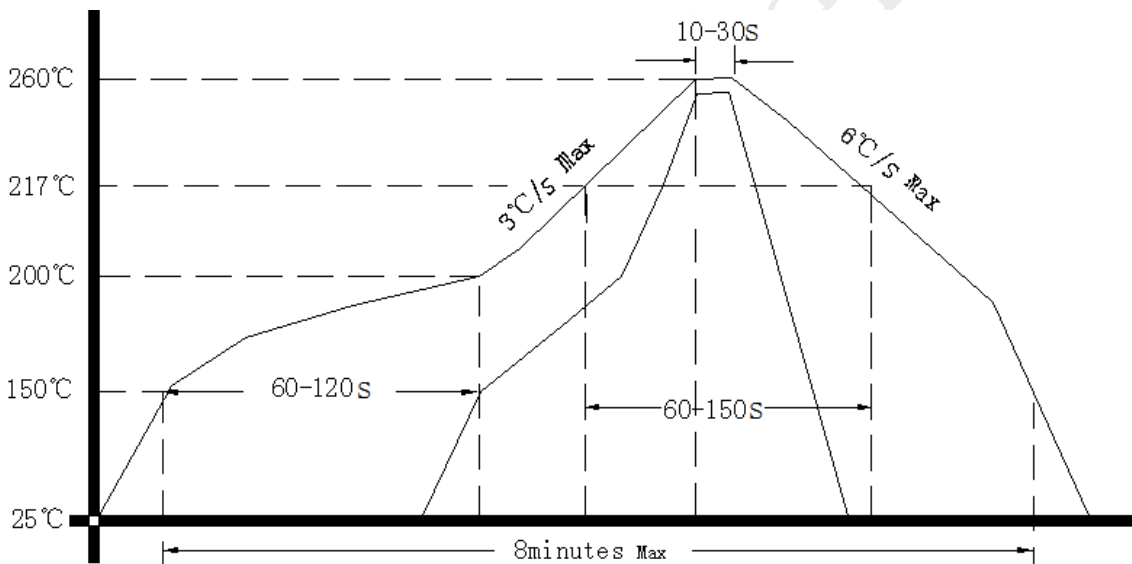

5. Package (mm)

