



1. Electrical Parameters

MODEL: T11A-0801-12.80MHz						
Item	Description	Parameters			Unit	Test Condition
		Min.	Typ.	Max.		
Output	Frequency	12.80			MHz	
	Output Waveform	LVCMOS				
	Output Low Voltage			0.4	V	$V_{cc}=3.3V, O_{load}=30\text{ pF}$
	Output High Voltage	2.8			V	$V_{cc}=3.3V, O_{load}=30\text{ pF}$
	Duty Cycle	45	50	55	%	@50%
	Rise / Fall Time (10%~90%)			5	ns	@25°C
	Load	30			pF	
Frequency Stabilities	Frequency Tolerance vs. Operating Temperature Range	-0.5		+0.5	$\times 10^{-6}$	T_A varied from -40°C to -20°C, measurement referenced to frequency observed with $T_A=25^\circ\text{C}, V_{cc}=3.3V, O_{load}=30\text{pF}$, temperature variable speed less than 2°C per minute.
		-0.28		+0.28	$\times 10^{-6}$	T_A varied from -20°C to 70°C, measurement referenced to frequency observed with $T_A=25^\circ\text{C}, V_{cc}=3.3V, O_{load}=30\text{pF}$, temperature variable speed less than 2°C per minute.
		-0.5		+0.5	$\times 10^{-6}$	T_A varied from 70°C to 85°C, measurement referenced to frequency observed with $T_A=25^\circ\text{C}, V_{cc}=3.3V, O_{load}=30\text{pF}$, temperature variable speed less than 2°C per minute.
	Initial Frequency Tolerance	-1		+1	$\times 10^{-6}$	Measurement referenced to frequency observed with $T_A=25^\circ\text{C} \pm 2^\circ\text{C}$, 10% load change and V_{cc} varied from 3.13V to 3.47V, within 30 days after ex-works.
	Frequency Tolerance vs. Supply Voltage	-0.2		+0.2	$\times 10^{-6}$	measurement referenced to frequency observed $T_A=25^\circ\text{C}, V_{cc}$ varied from 3.13V to 3.47V, and $O_{Load}=30\text{pF}$.
	Frequency Tolerance vs. Load	-0.2		+0.2	$\times 10^{-6}$	10% load change measurement referenced to frequency observed with $T_A=25^\circ\text{C}, V_{cc}=3.3V, O_{Load}=30\text{pF}$.
	Short-Term Stability: Allan Variance		-0.1		+0.1	$\times 10^{-9}$
		-0.3		+0.3	$\times 10^{-9}$	Temperature stability, no EMI\EMC or other interference, test after power for 30 mins ref. to 25°C; 10s, using PN9000 equipment.



	Aging Tolerance Per Day	-0.02		+0.02	$\times 10^{-6}$	$T_A=25^\circ\text{C}$, $V_{cc}=3.3\text{V}$, and after 1h of operation.
	Aging Tolerance 1 Year	-1		+1	$\times 10^{-6}$	
	Aging Tolerance 10 Years	-4.6		+4.6	$\times 10^{-6}$	
Power Supply	Current Consumption			5	mA	@ 25°C , $V_{cc}=3.3\text{V}$, $O_{load}=30\text{pF}$.
	Supply Voltage	3.13	3.3	3.47	V	
	Absolute Supply Voltage	2.64	3.3	3.96	V	
Phase Noise	Phase Noise @ 25°C			-90	dBc/Hz	10Hz
				-110		100Hz
				-130		1KHz
				-140		10KHz
				-145		100KHz
Environmental Conditions	Operable Temperature	-40		+85	$^\circ\text{C}$	
	Storage Temperature	-55		+105	$^\circ\text{C}$	
	ESD Level	Human Body Model,class2: 2000V to 4000V; ANSI/ESDA/JEDEC JS-001-2010.				
		Machine Model, class B: 200V to 400V; ANSI/ESDA/JEDEC JS-001-2010.				
	Moisture Sensitivity Level	Not humidity sensitive.				
	Bump	400m/s ² ; 6ms; (4000±10 times for each 3 directions X , Y , Z) .IEC 60068-2-29 Test Eb.				
	Vibration	Test Condition: 0.75mm ; 10Hz~55Hz, one cycle per 30 min. (each 3 directions X , Y , Z) .IEC 60068-2-06 Test Fc.				
Shock	1000 m/s ² ; 6ms; half sine wave (3 times for each 6 directions X , Y , Z),IEC 60068-2-27 Test Ea.					
Producibility	Solderability	IEC 600679-1 1997 4.6.3.1 Solderability ; GB/T2423.28-2005.				
	Resistant To Soldering Heat	IEC 600679-1 1997 4.6.3.2 Resistance to soldering heat ; GB/T2423.28-2005.				
	Inner Technology	IPCA-610D (Acceptability of Electronic Assemblies) .				
	Tensile Strength Of Leads	IEC 600679-1 1997 4.6.1.1 Tensile and thrust tests on terminations.				
Full Package Storage	Relative humidity (%)	20% ~ 70%				
	Temperature ($^\circ\text{C}$)	-10~35 $^\circ\text{C}$				



2. Mechanical Structure(mm)

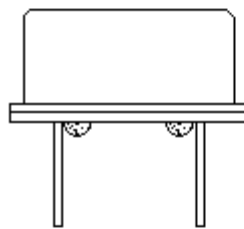
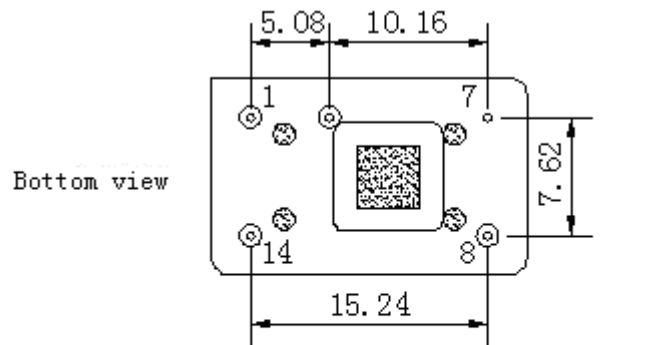

Right view

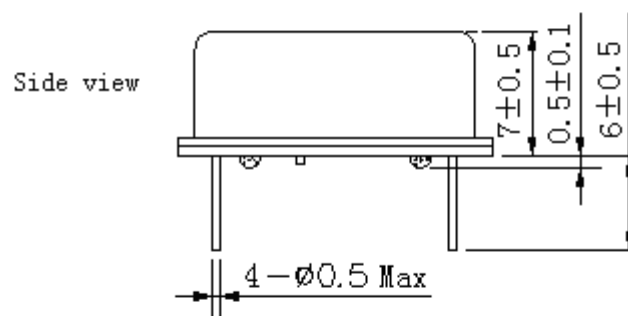

PIN FUNCTION

PIN	NOTATION	FUNCTION
1	NC	Not Connect
7	GND	GND
8	OUTPUT	RF Output
14	VCC	Supply Voltage

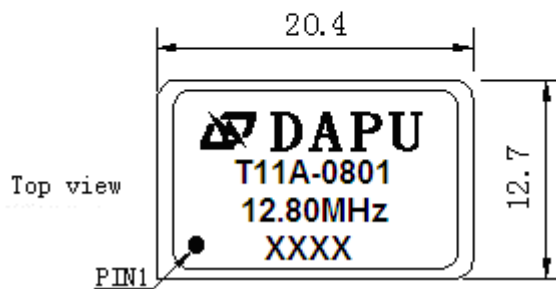

- Note1:** Tolerance $\pm 0.20\text{mm}$ without mark
- Note2:** The first two xx representative: week
After two xx representative: year
- Note3:** Referential Weight 3.8g
- Note4:** NC is not connect
- Note5:** Material composition and coating :
Pad/terminals: Fe-Co-Ni Alloy; Nickel Plating
Base: Fe
Cover: Stainless steel; Nickel Plating



3. Test circuit

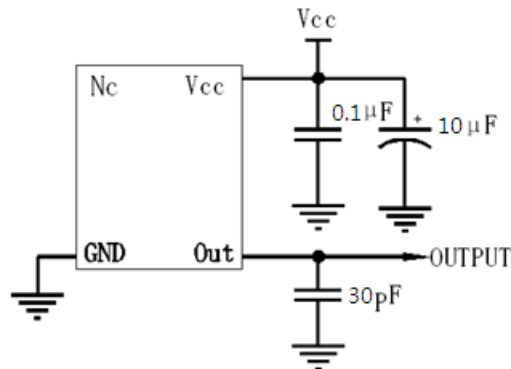

4. Reflow Soldering Curve (RoHS)



5. Package: PVC Tube,10pcs (mm)

