



1. Electrical Parameters

MODEL: O11M-2102-20.00MHz						
Item	Description	Parameters			Unit	Test Condition
		Min.	Typ.	Max.		
Output	Frequency	20.00			MHz	
	Output Waveform	HCMOS				
	Output Low Voltage			0.4	V	$V_{cc}=3.3V, O_{load}=15pF$
	Output High Voltage	2.4			V	$V_{cc}=3.3V, O_{load}=15pF$
	Duty Cycle	45	50	55	%	@50%
	Rise / Fall Time (10%~90%)			4	ns	
	Load	15			pF	
Frequency Stabilities	Frequency Tolerance vs. Operating Temperature Range	-0.02		+0.02	$\times 10^{-6}$	In still air, T_A varied from $-40^{\circ}C$ to $85^{\circ}C$, Measurement referenced $(F_{MAX}+F_{MIN})/2$, temperature variable speed less than $2^{\circ}C$ per minute.
	Initial Frequency Tolerance	-0.5		+0.5	$\times 10^{-6}$	Measurement referenced to frequency observed with $T_A=25^{\circ}C$, $V_{cc}=3.3V$, and after 15 minutes of operation, within 30 days after ex-works.
	Reflow Shift	-1		+1	$\times 10^{-6}$	After 1 hour recovery.
	Slope	-1		+1	$\times 10^{-9}/^{\circ}C$	In still air, temperature ramp $0.5^{\circ}C$ /minute.
	Frequency Tolerance vs. Supply Voltage	-0.01		+0.01	$\times 10^{-6}$	Measurement referenced to frequency observed $T_A=25^{\circ}C$, V_{cc} varied from 3.13V to 3.47V, and $O_{Load}=15pF$.
	Frequency Tolerance vs. Load	-0.01		+0.01	$\times 10^{-6}$	5% load change measurement referenced to frequency observed with $T_A=25^{\circ}C$, $V_{cc}=3.3V, O_{Load}=15pF$.
	Short-Term Stability: Allan Variance				1	$\times 10^{-9}$
				0.1	$\times 10^{-9}$	Temperature stability, no EMI/EMC or other interference, test after power for 1hour ref. to $25^{\circ}C$; 1s, using PN9000 equipment.



				0.05	$\times 10^{-9}$	Temperature stability, no EMI\EMC or other interference, test after power for 1hour ref. to 25°C; 10s , using PN9000 equipment.
				0.05	$\times 10^{-9}$	Temperature stability, no EMI\EMC or other interference, test after power for 1hour ref. to 25°C; 100s , using PN9000 equipment.
				0.05	$\times 10^{-9}$	Temperature stability, no EMI\EMC or other interference, test after power for 1hour ref. to 25°C; 1000s , using PN9000 equipment.
	Aging Tolerance Per Day	-3		+3	$\times 10^{-9}$	V _{cc} , T _A constant measurement referenced to frequency observed with T _A = 25°C, V _{cc} = 3.3V, and after 30 days of operation.
	Aging Tolerance First Year	-1		+1	$\times 10^{-6}$	
	Aging Tolerance 20 Years	-3		+3	$\times 10^{-6}$	
	Holdover 24 hours Drift	-3		+3	$\times 10^{-9}$	In still air , at constant temperature, temperature variation $\leq \pm 1^\circ\text{C}$, after 30 days of operation.
Overall Stability	-4.6		+4.6	$\times 10^{-6}$	Inclusive of the following: - operating temperature -40°C to 85°C - 3.3V $\pm 5\%$ - 15pF load $\pm 5\%$ - 2 times reflow soldering - 20 years aging reference to nominal frequency.	
Power Supply	Supply Voltage	3.13	3.3	3.47	V	
	Steady Consumption			150	mA	@25°C in still air
	Warm-up Time			3	minute	@25°C within $\pm 0.02 \times 10^{-6}$ of final frequency with reference after 1 hour on.
	Warm up current		300		mA	
Phase Noise	Phase Noise @25°C		-95		dBc/Hz	10Hz
			-120			100Hz
			-140			1KHz
			-147			10KHz
			-153			100KHz
			-153			1MHz



Environmental Conditions	Operable Temperature	-40		+85	°C	
	Storage Temperature	-55		+105	°C	
	ESD Level	Human Body Model,class2: 2000V to 4000V; ANSI/ESDA/JEDEC JS-001-2010.				
		Machine Model, class B: 200V to 400V; ANSI/ESDA/JEDEC JS-001-2010.				
	Moisture Sensitivity Level	Level 1.				
	Vibration	Test Condition: 0.75mm ;acceleration:10g;10Hz~500Hz, one cycle per 30 min, test 2 hour. (3 times for each 3 directions X ,Y , Z), IEC 68-2-06 Test Fc.				
Shock	50g; 11ms; half sine wave (3 times for each 3 directions X ,Y, Z),IEC 68-2-27 Test Ea/Severity 50A.					
Full Package Storage	Relative humidity (%)	20%~70%				
	Temperature (°C)	-10~35°C				



2. Mechanical Structure(mm)

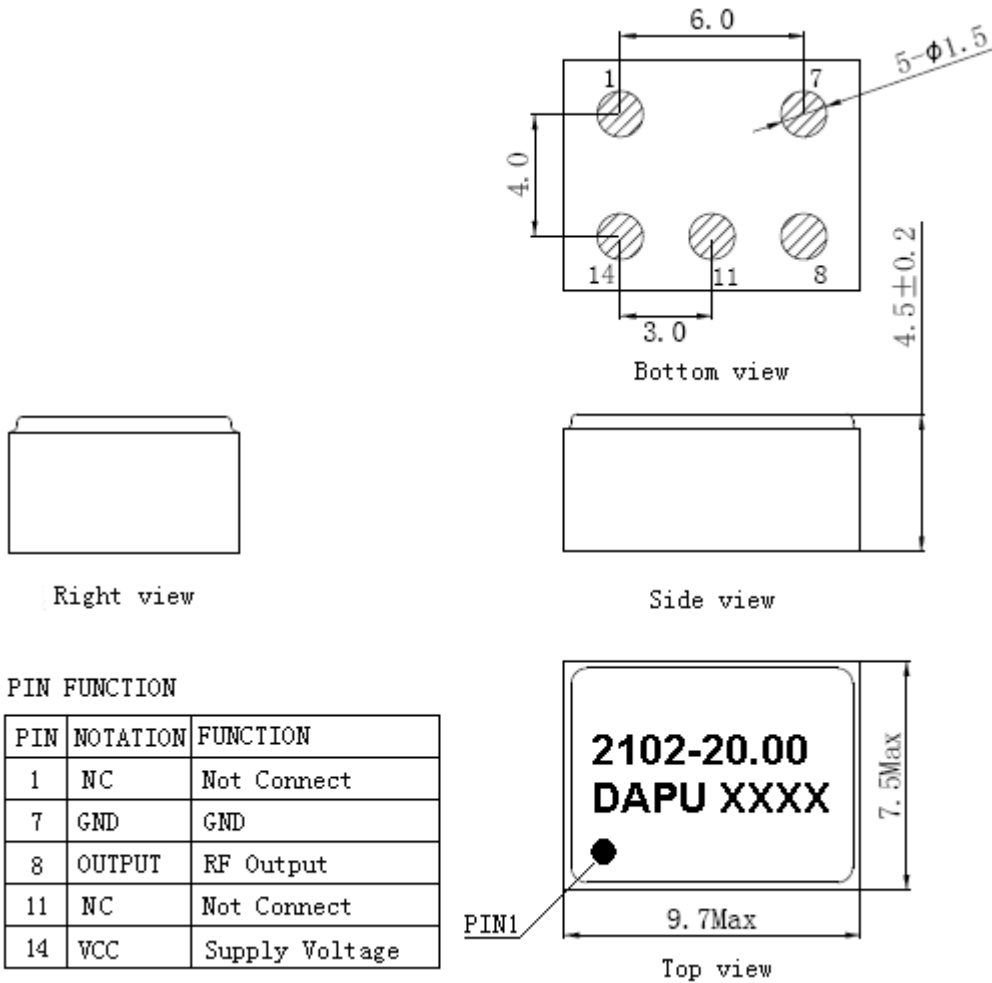

Note1: Tolerance $\pm 0.20\text{mm}$ without mark

Note2: The first two xx representative: week
After two xx representative: year

Note3: NC is not connect

Note4: Material composition :
Pad/terminals: Cu (Surface plating: Ni 3-6um, Au 0.1~0.5um)
Base: Al_2O_3
Cover: Zinc-copper-nickel alloy



3. Test Circuit

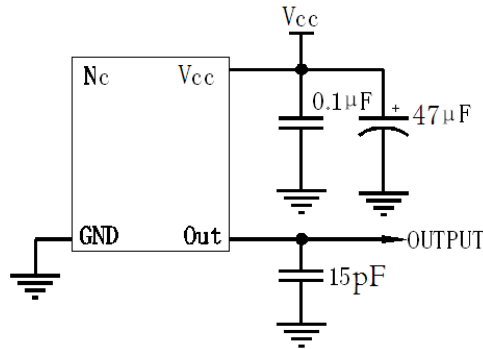

4. Reflow Soldering Curve (RoHS)

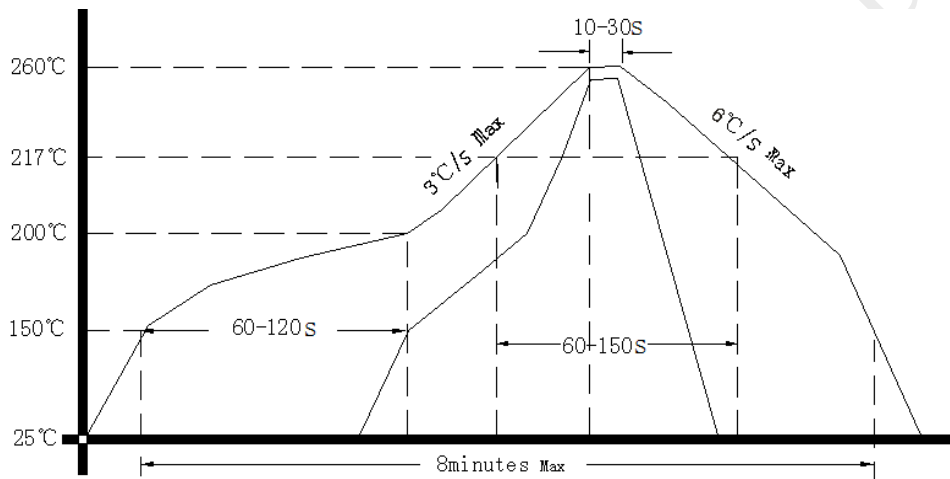

5. Package: Tape & Reel (mm)

