

Travelling Merchant: _____

DATASHEET

Standard: **O23B-R146-10.00MHz**

Plot			The Label
Drew	Audited	Approved	Stamp, please! Thanks!
Date: _____			

Guangdong Dapu Telecom Technology Co.,Ltd

Bldg13,.N.Ind.Zone,SSL Industry Park, Dongguan City, Guangdong Province, China

TEL: 0086-0769-88010888 FAX: 0086-0769-81800098



1、Electrical Parameters

MODEL: O23B-R146-10.00MHz						
Item	Description	Parameters			Unit	Test Condition
		Min.	Typ.	Max.		
Output	Frequency	10.00			MHz	
	Output Waveform	LV-TTL				
	Output Low Voltage			+0.4	V	V _{cc} =12.0V, O _{load} =15pF
	Output High Voltage	+2.4			V	V _{cc} =12.0V, O _{load} =15pF
	Duty Cycle	45	50	55	%	@50%
	Rise / Fall Time			6	ns	10%~90%
	Load	15			pF	
	Spurious Suppression			-60	dBc	
Frequency Stabilities	Frequency Tolerance vs. Operating Temperature Range			+0.05	ppb	T _A varied from 0°C to 50°C, measurement referenced to frequency observed with T _A = 25°C, V _{cc} =12.0V, V _C =2.5V, O _{load} =15pF, temperature rise speed less than 2°C per minute.
				+0.1	ppb	T _A varied from -10°C to 70°C, measurement referenced to frequency observed with T _A = 25°C, V _{cc} =12.0V, V _C =2.5V, V _{Oload} =15pF, temperature rise speed less than 2°C per minute.
	Initial Frequency Tolerance	-0.08		+0.08	ppm	after power on 30 minutes, 25°C, at control voltage, at 2.5V(after retrace).
	Frequency Tolerance vs. Supply Voltage	-0.1		+0.1	ppb	measurement referenced to frequency observed T _A =25°C, V _{cc} varied from 11.4V to 12.6V, V _C =2.5V.
	Frequency Tolerance vs. Load	-0.1		+0.1	ppb	10% load change measurement referenced to frequency observed with T _A = 25°C, V _{cc} =12V, V _C =2.5V. O _{Load} =15pF.
	Retrace after stabilization	-0.01		+0.01	ppm	after 15 minutes power on at ±25°C, reference to the frequency after 48 hours power on, prior to 24 hours turn off.
	Daily fluctuation	-0.5		+0.5	ppb	
Short-Term Stability: Allan Variance				0.01	ppb	Temperature stability, no EMI\EMC or other interference, test after power for 1hour ref. to 25°C; 1s, using PN9000 equipment.
				0.05	ppb	Temperature stability, no EMI\EMC or other interference, test after power for 1hour ref. to 25°C; 100s, using PN9000 equipment.



	Aging Tolerance Per Day	-0.2		+0.2	ppb	V _{cc} , V _C , T _A constant measurement referenced to frequency observed with T _A = 25°C, V _{cc} = 12.0V, V _C =2.5V, and after 30 days of operation.
	Aging Tolerance 1 Year	-0.03		+0.03	ppm	
	Aging Tolerance 10 Years	-0.3		+0.3	ppm	
	Aging Tolerance 15 Years	-0.4		+0.4	ppm	
Power Supply	Supply Voltage	11.4	12	12.6	V	
	Current Consumption			200	mA	@25°C
	Current Consumption during warm up			600	mA	
Voltage Control Characteristics	Frequency Tuning Range	-0.8		-0.4	ppm	V _C = 0 V. measurement referenced to V _C =2.5V
		-0.08		+0.08	ppm	V _C =2.5V. measurement referenced to exactly 10.00MHz
		+0.4		+0.8	ppm	V _C =5.0V. measurement referenced to V _C =2.5V
	Linearity			10	%	
	Slope	Positive				
	Input Impedance	100			K Ohm	
Phase Noise	Phase Noise		-95		dBc/Hz	1Hz
			-120			10Hz
			-140			100Hz
			-145			1KHz
			-150			10KHz
			-150			100KHz
Environmental Conditions	Operable Temperature	-10		+70	°C	
	Storage Temperature	-40		+85	°C	
	Vibration	Test Condition: 0.75mm ;acceleration:10g;10Hz~500Hz, one cycle per 30 min, test 2 hour. (3 times for each 3 directions X ,Y , Z), IEC 68-2-06 Test Fc.				
	Shock	50g; 11ms; half sine wave (3 times for each 3 directions X ,Y , Z),IEC 68-2-27 Test Ea/Severity 50A.				



2、Mechanical Structure(mm)

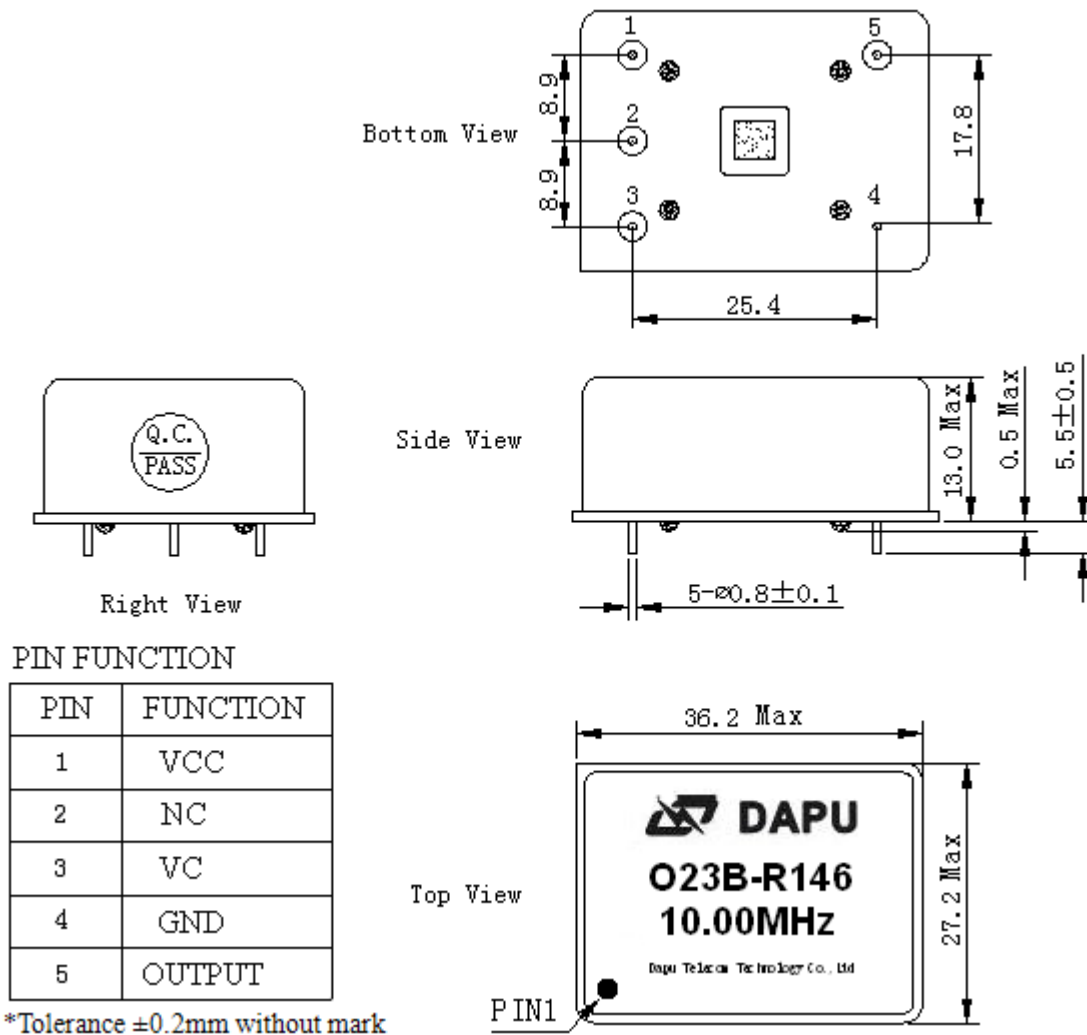

Note1: Referential Weight 21.0g

3、Test Circuit

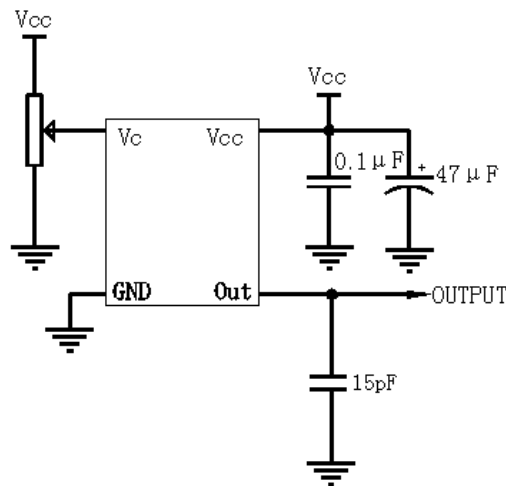



4、 Wave Soldering Curve (RoHS)

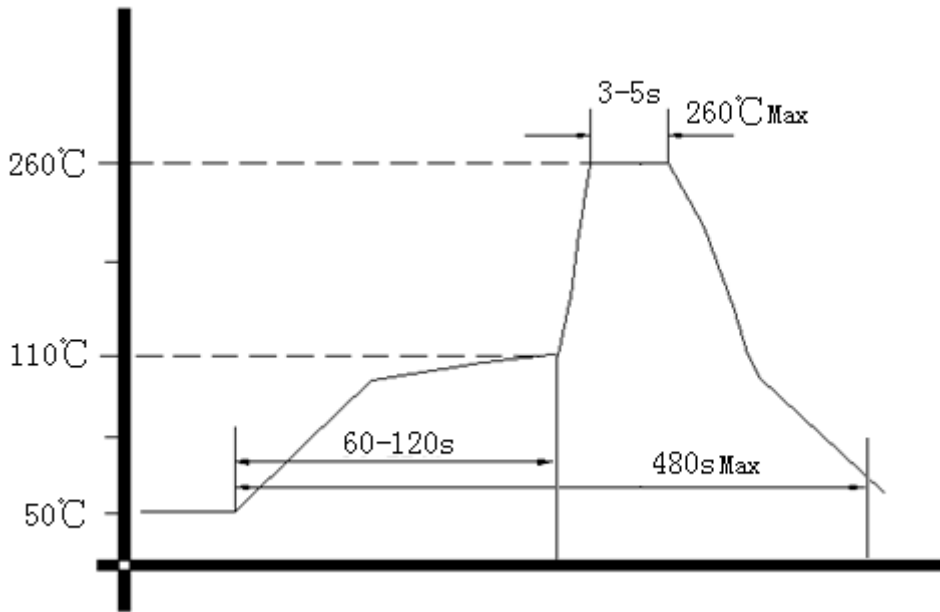

5、 Package: PVC Tube,8pcs (mm)

