







## 1. Electrical Parameters

MODEL: O22A-1801-38.88MHz						
Item	Description	Parameters			Unit	Test Condition
		Min.	Typ.	Max.		
Output	Frequency	38.88			MHz	
	Output Waveform	HCMOS				
	Output Low Voltage			0.5	V	$V_{cc}=5.0V, O_{load}=15pF$
	Output High Voltage	4.3			V	$V_{cc}=5.0V, O_{load}=15pF$
	Duty Cycle	45	50	55	%	@50%
	Rise / Fall Time (10%~90%)			5	ns	
	Load	15			pF	
Frequency Stabilities	Frequency Tolerance vs. Operating Temperature Range	-0.2		+0.2	$\times 10^{-6}$	$T_A$ varied from $-40^{\circ}C$ to $75^{\circ}C$ , measurement referenced to frequency observed with $T_A=25^{\circ}C, V_{cc}=5.0V, O_{load}=15pF$ , temperature rise speed less than $2^{\circ}C$ per minute.
	Frequency Accuracy	-0.5		+0.5	$\times 10^{-6}$	Within 90 days after shipment and 15 minutes warm up time, Measurement referenced to exactly 38.88MHz
	Initial Frequency Tolerance	-0.5		+0.5	$\times 10^{-6}$	Measurement referenced to frequency observed with $T_A=25^{\circ}C, V_{cc}=5.0V$ , and after 15 minutes of operation referenced to 1 hour of operation.
	Frequency Tolerance vs. Supply Voltage	-0.05		+0.05	$\times 10^{-6}$	measurement referenced to frequency observed $T_A=25^{\circ}C, V_{cc}$ varied from 4.75V to 5.25V, and $O_{Load}=15pF$ .
	Frequency Tolerance vs. Load	-0.05		+0.05	$\times 10^{-6}$	10% load change measurement referenced to frequency observed with $T_A=25^{\circ}C, V_{cc}=5.0V$ , and $O_{Load}=15pF$ .
	Short-Term Stability: Allan Variance			0.1	$\times 10^{-9}$	Temperature stability, no EMI/EMC or other interference, test after power for 1hour at $25^{\circ}C$ ; 1s, using PN9000 equipment.
	Aging Tolerance Per Day	-0.01		+0.01	$\times 10^{-6}$	$V_{cc}, T_A$ constant measurement referenced to frequency observed with $T_A=25^{\circ}C, V_{cc}=5.0V$ , and after 30 days of operation.
	Aging Tolerance 1 Year	-0.5		+0.5	$\times 10^{-6}$	
	Aging Tolerance 10 Year	-3		+3	$\times 10^{-6}$	



Power Supply	Supply Voltage	4.75	5.0	5.25	V	
	Steady Consumption			300	mA	@25°C
	Warm up current			600	mA	
	Warm-Up Time			5	minutes	
Phase Noise	Phase Noise			-60	dBc/Hz	1Hz
				-115		100Hz
				-145		10KHz
Environmental Conditions	Operable Temperature	-40		+75	°C	
	Storage Temperature	-40		+85	°C	
	ESD Level	Human Body Model, class2: 2000V to 4000V; ANSI/ESDA/JEDEC JS-001-2010.				
		Machine Model, class B: 200V to 400V; ANSI/ESDA/JEDEC JS-001-2010.				
	Moisture Sensitivity Level	Not humidity sensitive.				
	Vibration	Test Condition: 0.75mm ;acceleration:10g;10Hz~500Hz, one cycle per 30 min, test 2 hour. (3 times for each 3 directions X , Y , Z), IEC 68-2-06 Test Fc.				
Shock	50g; 11ms; half sine wave (3 times for each 3 directions X, Y, Z), IEC 68-2-27 Test Ea/Severity 50A.					



## 2. Mechanical Structure (mm)

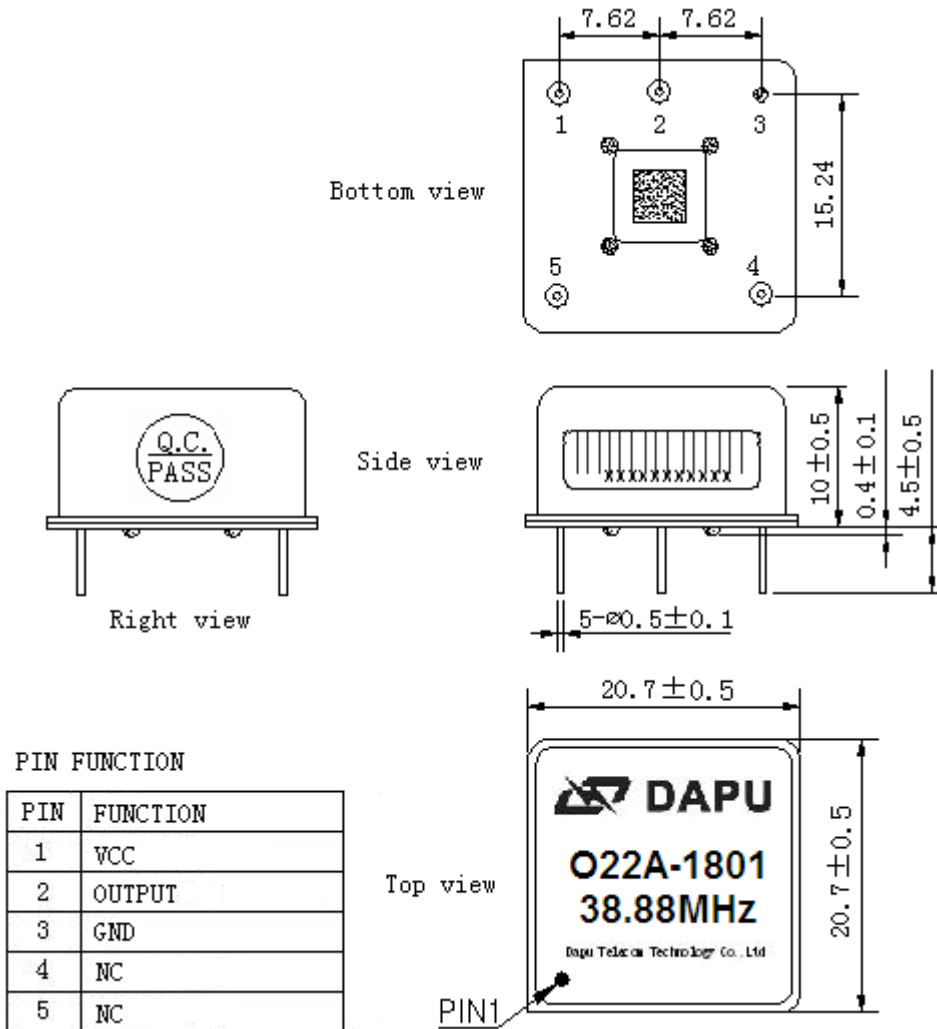

**Note1:** Tolerance  $\pm 0.2\text{mm}$  without mark

**Note2:** Referential Weight 8.0g

**Note3:** NC is not connect

## 3. Test Circuit

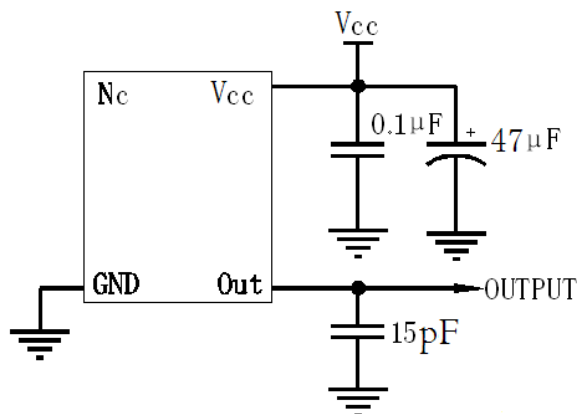



#### 4. Reflow Soldering Curve (RoHS)



#### 5. Package (mm)

