

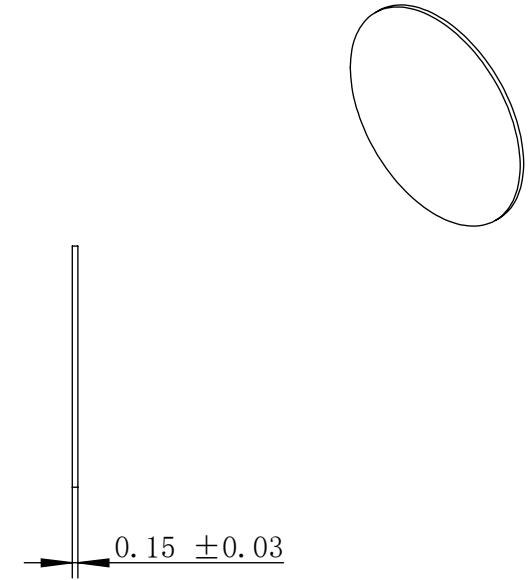

RoHS COMPLIANT

REVISIONS				
REV.	ECN NO.	DESCRIPTION	DATE	REVISOR
A	-	Producing release	2022/3/22	ZC.Wu

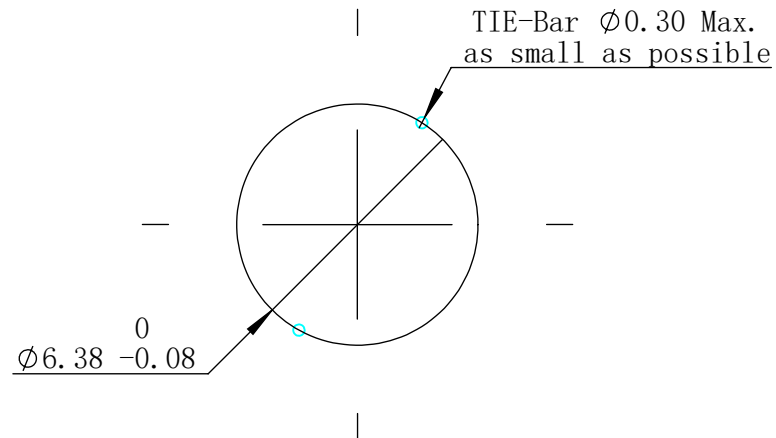

NOTES:

1. MATERIAL:COLD ROLL STEEL
2. FINISH:SILVER, PER DP PLATING STANDARDS FILE PSF-00001(LATEST RVE.)
3. ANY UNDIMENSIONED FEATURES TO MEET CAD FILE
4. UNLESS OTHERWISE SPECIFIED, REMOVE ALL BURRS VISIBLE WITHOUT MAGNIFICATION
5. ALL DIMENSIONAL LIMITS APPLY AFTER FINISH
6. ALL THE DIMENSION MUST BE INSPECTED BY IQC.

PART NAME: 匀磁片	Designed:	ZC. Wu	
	Checked:		
DRAWING NO. : PPF-00166	Approval:		TOLERANCES ON
	The first angle projection: 		
DESCRIPTION: POLE PIECE	Sheet 1 of 1		.x ± 0.10
	Scale:	Unit:	.xx ± 0.05
	1:1	mm	$\pm 0.5^\circ$
		-	.xxx ± 0.02