

Customer Code: _____

DATASHEET

DAPU P/N: JC2520C-B5A9CD-26.00MHz-D0

DAPU			Customer Approval
Drew	Audited	Approved	Stamp, please! Thanks!
Jieshu ZHENG	Jianhua LIN	Gangtao FENG	
Date:	2024/7/9		

Guangdong Dapu Telecom Technology Co.,Ltd

Bldg 5, SSL Modern Enterprise Accelerator Zone, Dongguan City, Guangdong Province, PRC China
TEL: 0086-0769-88010888 FAX: 0086-0769-81800098

1、Electrical Parameter

MODEL:		JC2520C-B5A9CD-26.00MHz-D0				
No.	Description	Parameters			Units	Test Condition
		Min.	Typ.	Max.		
Output	Frequency	26.000			MHz	
	Output Waveform	Clipped Sine Wave				
	Output Level	0.8			V _{p-p}	
	Spurious Suppression			-8	dBc	
	Load	10KΩ//10pF			-	
Frequency Stabilities	Frequency Tolerance	-1.5		1.5	×10 ⁻⁶	@25±2°C, 2H, after 2 times reflow soldering, base on nominal frequency.
	vs. Temperature	-0.5		0.5	×10 ⁻⁶	T _A varied from -40°C to 85°C, measurement referenced to frequency observed with f _{ref} =(f _{max} +f _{min})/2, V _{CC} =1.8V, O _{load} =10KΩ//10pF, temperature variable speed less than 2°C per minute.
	vs. Supply Voltage	-0.1		0.1	×10 ⁻⁶	measurement referenced to frequency observed T _A =25°C, V _{cc} =1.8±5%, and O _{Load} =10KΩ//10pF.
	vs. Load	-0.1		0.1	×10 ⁻⁶	10% load change measurement referenced to frequency observed with T _A =25°C, V _{cc} =1.8V, and O _{Load} =10KΩ//10pF.
	Aging Tolerance 1 Year	-1		1	×10 ⁻⁶	T _A =25°C, V _{cc} =1.8V, and after 1h of operation.
	Frequency Slope	-0.1		0.1	ppm/°C	T _A varied from -40°C to 85°C
	Power Supply	Current consumption			2.5	mA
Start up Time				2	ms	More than 90% of final output voltage
Supply Voltage		1.71	1.80	3.63	V	
SSB Phase Noise	Phase Noise@25±2°C			-45	dBc/Hz	1Hz
				-83		10Hz
				-111		100Hz
				-135		1KHz
				-151		10KHz
				-153		100KHz
				-154		1MHz

Environmental Conditions	Operable Temperature	-40		85	°C	
	Storage Temperature	-55		105	°C	
	ESD Level	Human Body Model, class 2: 2000V to 4000V; ANSI/ESDA/JEDEC JS-001-2010.				
		Machine Model, class B: 200V to 400V; JEDEC JESD22-A115C.				
	Moisture Sensitivity Level	Level 3.				
	Vibration	Test Condition: 0.75mm ;acceleration:10g;10Hz~2000Hz, one cycle per 30 min, test 2 hour. (3 times for each 3 directions X ,Y, Z) .IEC 68-2-06 Test Fc.				
Shock	100g; 6ms; half sine wave (3 times for each 3 direction s X ,Y, Z), IEC 68-2-27 Test Ea/Severity 50A.					
Full Package Storage	Relative humidity (%)	20%~70%				
	Temperature (°C)	-10~35°C				

2 Test Circuit

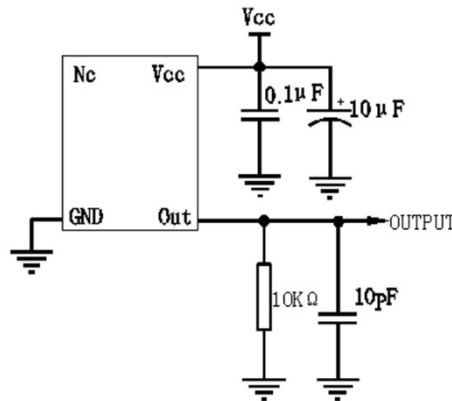

3. Reflow Soldering Curve (RoHS)

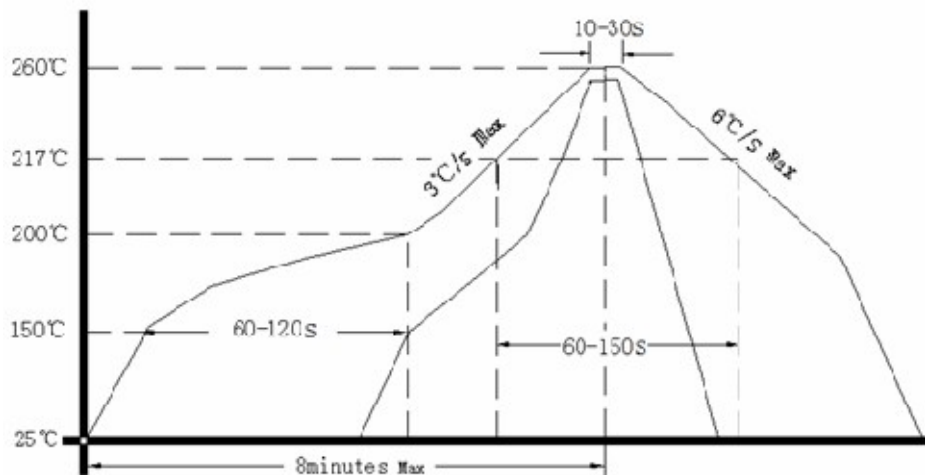

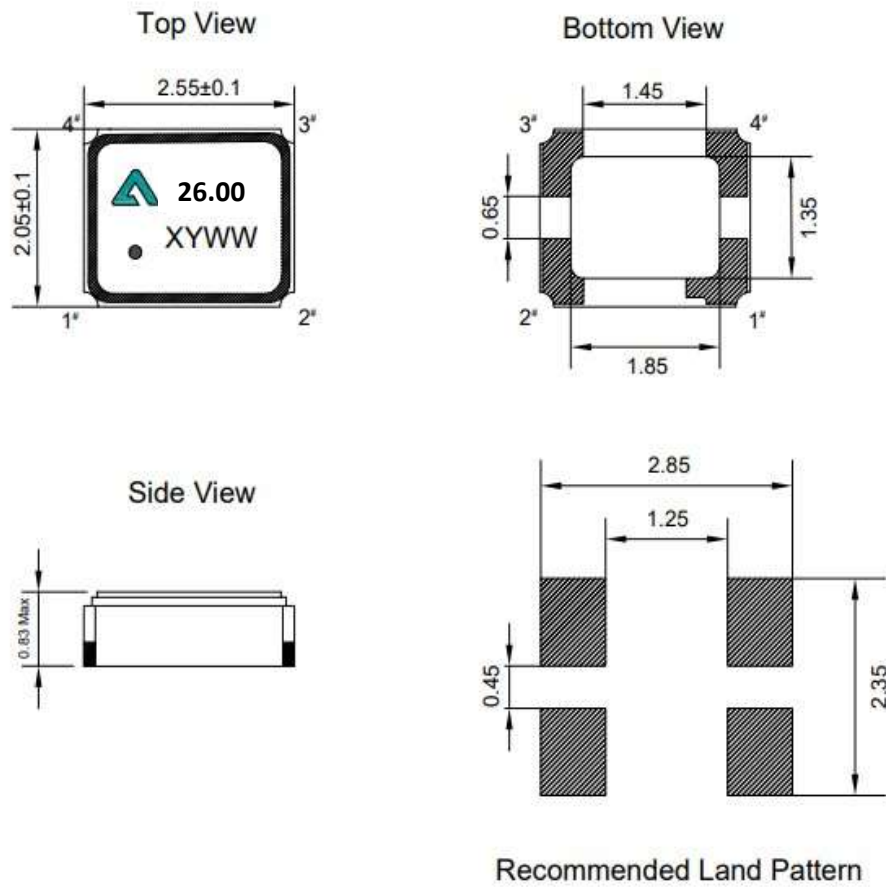

4、 Mechanical Structure(mm)



PIN NAME	CONNECTION
PIN1	OE
PIN2	GND
PIN3	OUTPUT
PIN4	VCC

5、 Marking Information

26.00:	Frequency 26.00MHz
 :	DAPU Logo
X:	Lot No.
Y:	Year
WW:	Week
 :	Pin1 Index



6、 Packing Information

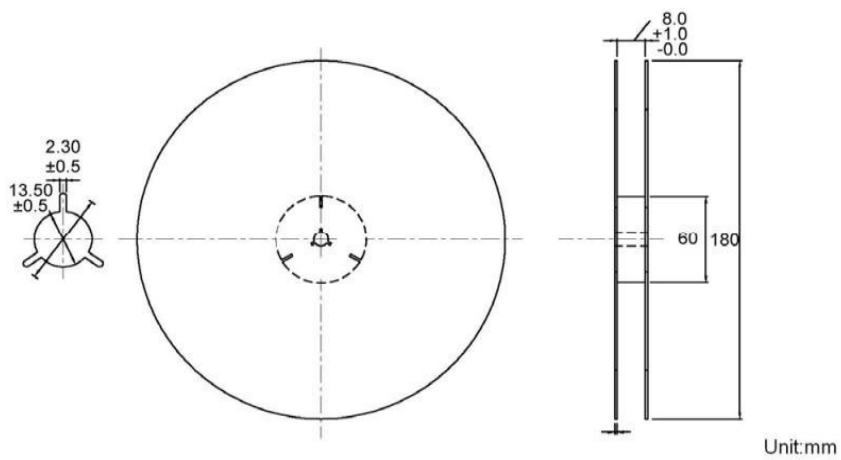
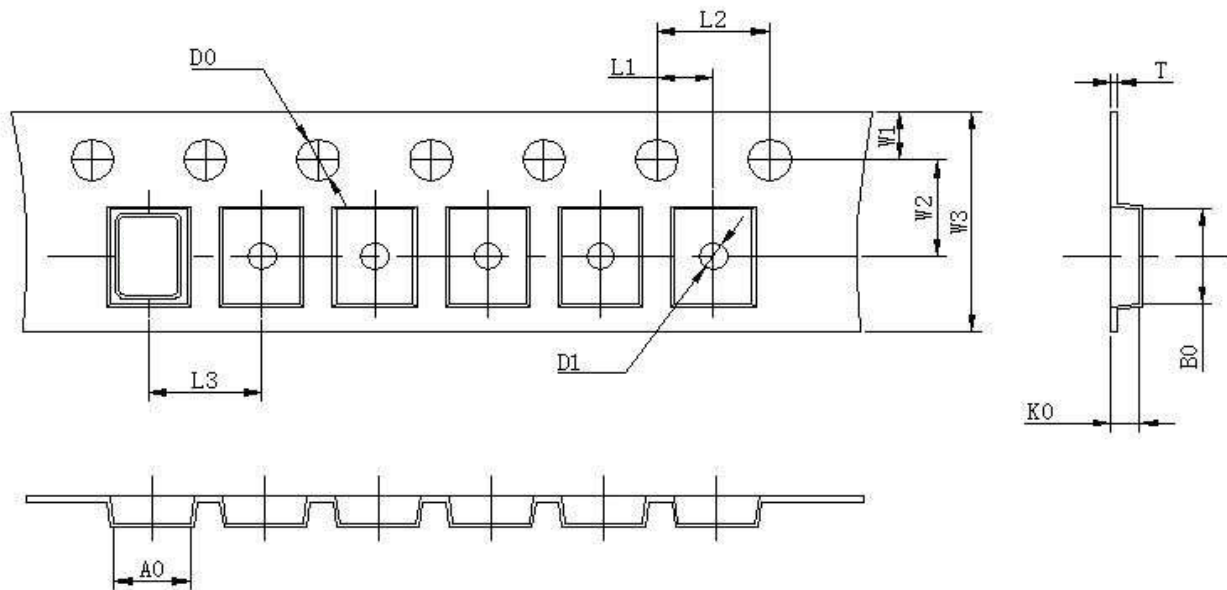

L1	2.00 ±0.1
L2	4.00 ±0.1
L3	4.00 ±0.1
D0	1.55 ±0.05
D1	1.20 ±0.5
W1	1.75 ±0.1
W2	3.50 ±0.1
W3	8.00 ±0.2
A0	2.25 ±0.1
B0	2.7 ±0.1
K0	1.45 ±0.1
T	0.25 ±0.05