

CUSTOMER: _____

DATASHEET

PRODUCT TYPE: DPTC2016

DAPU P/N: T2016C-A579-52.00MHz-X337

Plot			The Label
Drew	Audited	Approved	Stamp, please! Thanks!
Jieshu ZHENG	Jianhua LIN	Gangtao FENG	
Date: 2024.10.8			

Guangdong Dapu Telecom Technology Co.,Ltd

Building 5, No.24, Industrial East Road, Songshanhu Park, Dongguan, Guangdong, P.R. China

TEL: 0086-0769-88010888 FAX: 0086-0769-81800098



1. Electrical Parameters

MODEL: T2016C-A579-52.00MHz-X337						
Item	Description	Parameters			Unit	Test Condition
		Min.	Typ.	Max.		
Output	Frequency	52.00			MHz	
	Output Waveform	Clipped Sine Wave				
	Vp-p	0.8			V	
	Load	10KΩ//10pF				
	Harmonic	-	-	-8	dBc	
Frequency Stabilities	Frequency Tolerance	-1.5		+1.5	$\times 10^{-6}$	@25±2°C, 2H, after 2 times reflow soldering, base on nominal frequency.
	vs. Temperature	-0.5		+0.5	$\times 10^{-6}$	T _A varied from -40°C to 85°C, measurement referenced to frequency observed with f _{ref} =(f _{max} +f _{min})/2, V _{cc} =1.8V, O _{load} =10KΩ//10pF, temperature variable speed less than 2°C per minute.
	vs. Supply Voltage	-0.1		+0.1	$\times 10^{-6}$	measurement referenced to frequency observed T _A =25°C, V _{cc} = 1.8±5%, and O _{Load} =10KΩ//10pF.
	vs. Load	-0.1		+0.1	$\times 10^{-6}$	10% load change measurement referenced to frequency observed with T _A =25°C, V _{cc} =1.8V, and O _{Load} =10KΩ//10pF .
	Aging Tolerance 1 Year	-1		+1	$\times 10^{-6}$	T _A =25°C, V _{cc} =1.8V, and after 1h of operation.
	Frequency Slope	-0.1		0.1	ppm/°C	T _A varied from -40°C to 85°C
Power Supply	Current consumption			3	mA	@25°C, V _{cc} =1.8V, O _{Load} =10KΩ//10pF.
	Start up Time			2	ms	More than 90% of final output voltage
	Supply Voltage	1.71	1.8	1.89	V	
				-105	dBc/Hz	100Hz
				-127		1KHz
				-145		10KHz
				-150		100KHz
			-150	1MHz		



Environmental Conditions	Operable Temperature	-40		+85	°C	
	Storage Temperature	-40		+85	°C	
	ESD Level	Human Body Model, class2: 2000V; ANSI/ESDA/JEDEC JS-001-2010.				
		Machine Model, class B: 200V; JEDEC JESD22-A115C.				
	Moisture Sensitivity Level	Level 1.				
	Vibration	Test Condition: 0.75mm ;acceleration:10g;10Hz~2000Hz, one cycle per 30 min, test 2 hour. (3 times for each 3 directions X ,Y , Z) .IEC 68-2-06 Test Fc.				
Shock	100g; 6ms; half sine wave (3 times for each 3 directions X ,Y, Z),IEC 68-2-27 Test Ea/Severity 50A.					
Full Package Storage	Relative humidity (%)	20%~70%				
	Temperature (°C)	-10~35°C				

2. Mechanical Structure(mm)

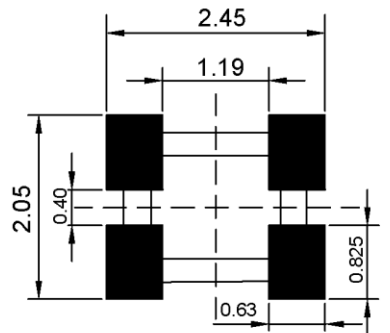
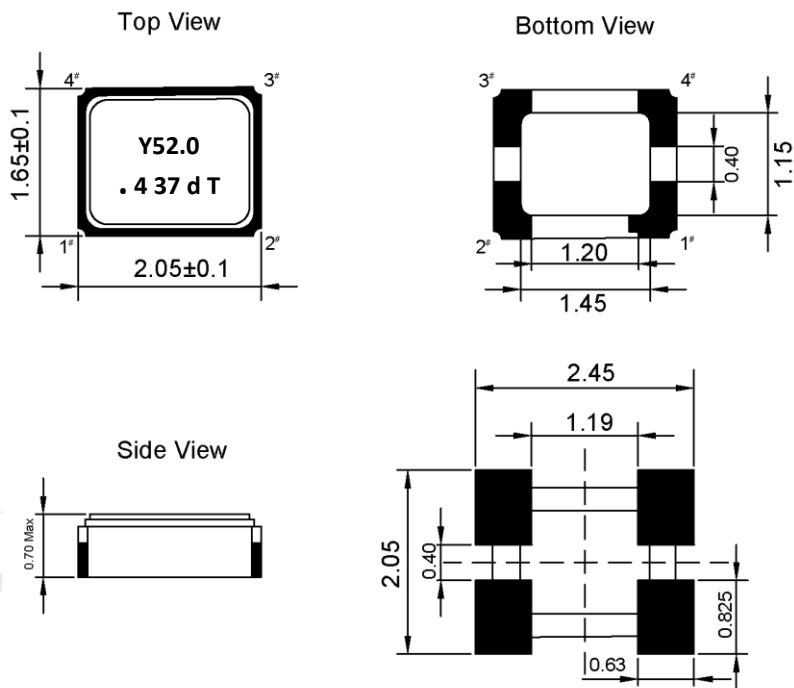

Recommended Land Pattern

PIN NAME	CONNECTION
PIN1	NC
PIN2	GND
PIN3	OUTPUT
PIN4	VCC

Note1: N/C is not connected



3. Marking Information

<p>Y: Fixed characters 52.0: Frequency 4: Year. 37: Week. d: Fixed characters T: Fixed characters ● : Pin1 Index</p>	
--	--

4. Test Circuit

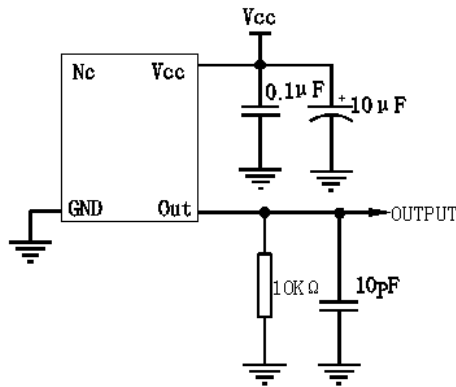

5. Reflow Soldering Curve (RoHS)

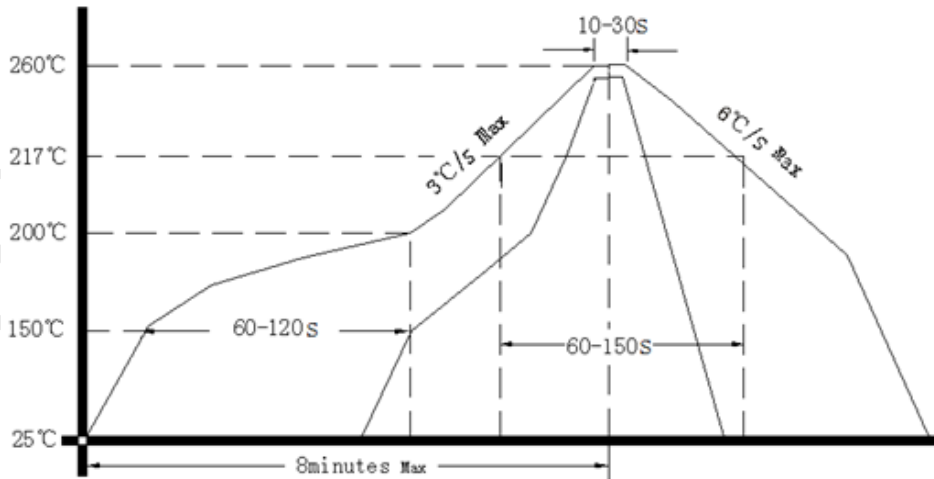



6. Packing Information

1) Carrier tape and taping reel sizes (Unit: mm)

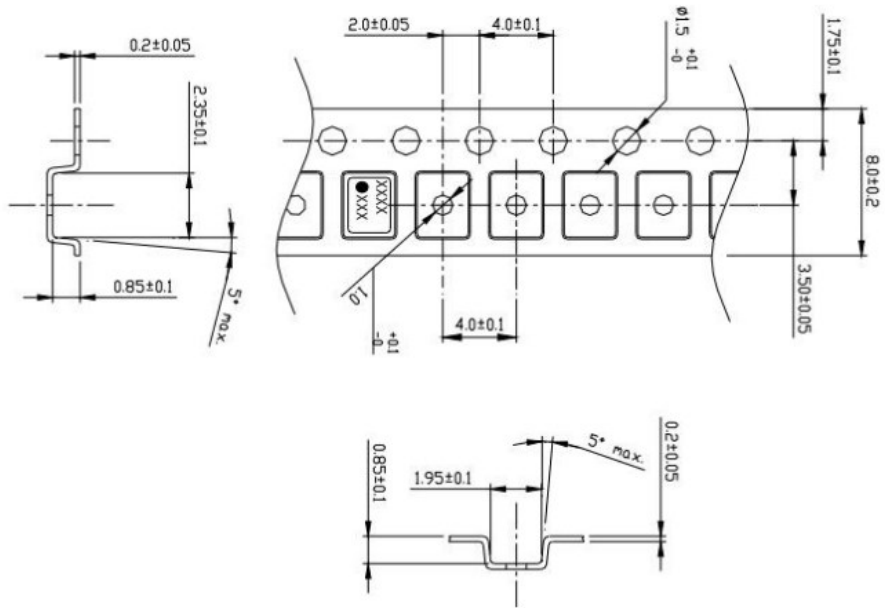

1. Clearance of an embossing tape, and a product unit: mm

Direction	Pocket size	TCXO size	Clearance
L	2.35±0.10	2.00±0.15	0.35±0.25
W	1.95±0.10	1.60±0.15	0.35±0.25
H	0.85±0.05	0.70±0.10	0.15±0.15

2. Quality : Polystyrene (Conductivity)

3. Tensile strength of an embossing tape : more than 14N

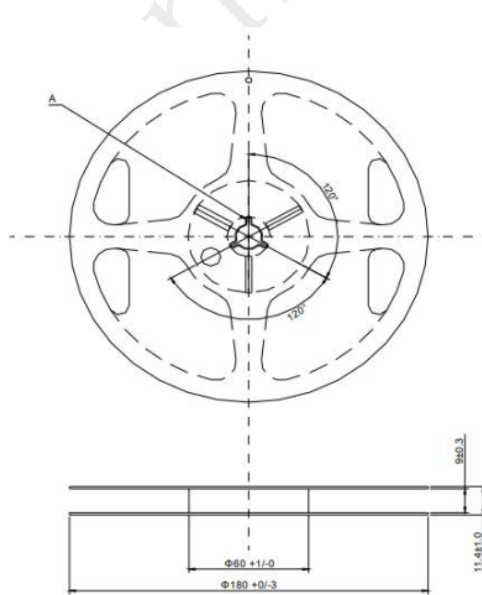

Material: Polystyrene (Conductivity)
unit: mm

Section A

