

Customer Code : _____

DATASHEET

DAPU P/N: CM21Z-O118-100.00MHz

Customer P/N: _____

DAPU			Customer Approval
Drew	Audited	Approved	Stamp, please! Thanks!
Date: 2024.12.11			

Guangdong Dapu Telecom Technology Co.,Ltd

Building 5, No.24, Industrial East Road, Songshanhu Park, Dongguan, Guangdong, P.R. China

TEL: 0086-0769-88010888 FAX: 0086-0769-81800098



1. Electrical Parameters

MODEL: CM21Z-O118-100.00MHz						
Item	Description	Parameters			Unit	Test Condition
		Min.	Typ.	Max.		
Input	Frequency	10.00			MHz	
	Input Waveform	Sine Wave				
	Level	1		8	dBm	
	Harmonics Suppression			-40	dBc	
	Spurious Suppression			-70	dBc	
	Input Impedance	50			Ω	
Output	Frequency	100.00			MHz	
	Output Waveform	Sine Wave				
	Level	5			dBm	
	Harmonics Suppression			-30	dBc	
	Spurious Suppression			-65	dBc	
	Load	50			Ω	
Power Supply	Supply Voltage	4.75	5	5.25	V	
	Steady Consumption			150	mA	@25°C
	Warm up current			380	mA	
Phase Noise	Phase Noise			-87	dBc/Hz	10Hz
				-120		100Hz
				-148		1KHz
				-158		10KHz
				-165		100KHz
				-165		1MHz
Environmental Conditions	Operable Temperature	-40		+85	°C	
	Storage Temperature	-55		+105	°C	
	ESD Level	Human Body Model, class2: 2000V to 4000V; ANSI/ESDA/JEDEC JS-001-2010.				
		Machine Model, class B: 200V to 400V; ANSI/ESDA/JEDEC JS-001-2010.				
	Moisture Sensitivity Level	Not humidity sensitive.				
	Vibration	Test Condition: 0.75mm ;acceleration:10g;10Hz~500Hz~10Hz, test 1 hour. (in 3 directions X , Y , Z), GJB 360B-2009 Test Ea 204.				
	Shock	100g; 6ms; half sine wave (3 times for each 3 directions X , Y , Z), GJB 360B-2009 Test Ea 213				
Full Package Storage	Relative humidity (%)	20%~70%				
	Temperature (°C)	-10~35°C				



2. Mechanical Structure(mm)

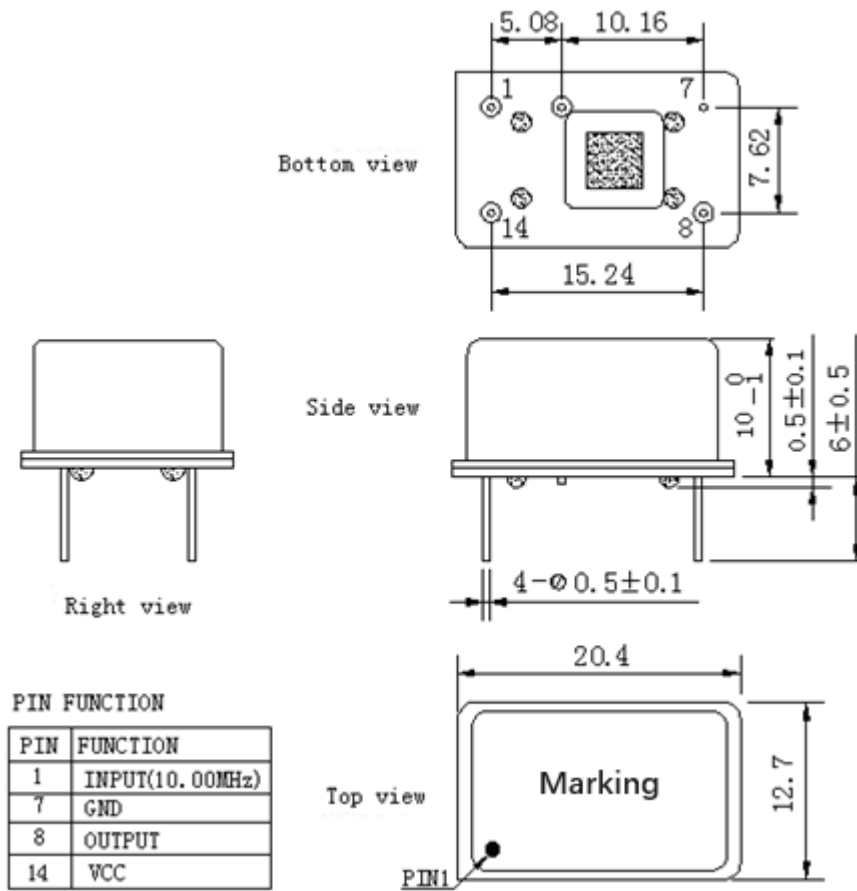

Marking:



Note1: Tolerance $\pm 0.2\text{mm}$ without mark

Note2: The first two xx representative: year
After two xx representative: week

Note3: Referential Weight 4.2g



3. Test circuit

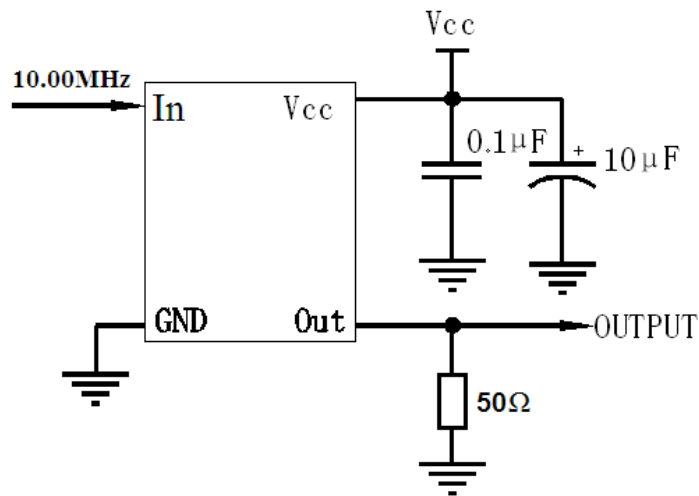

4. Reflow Soldering Curve

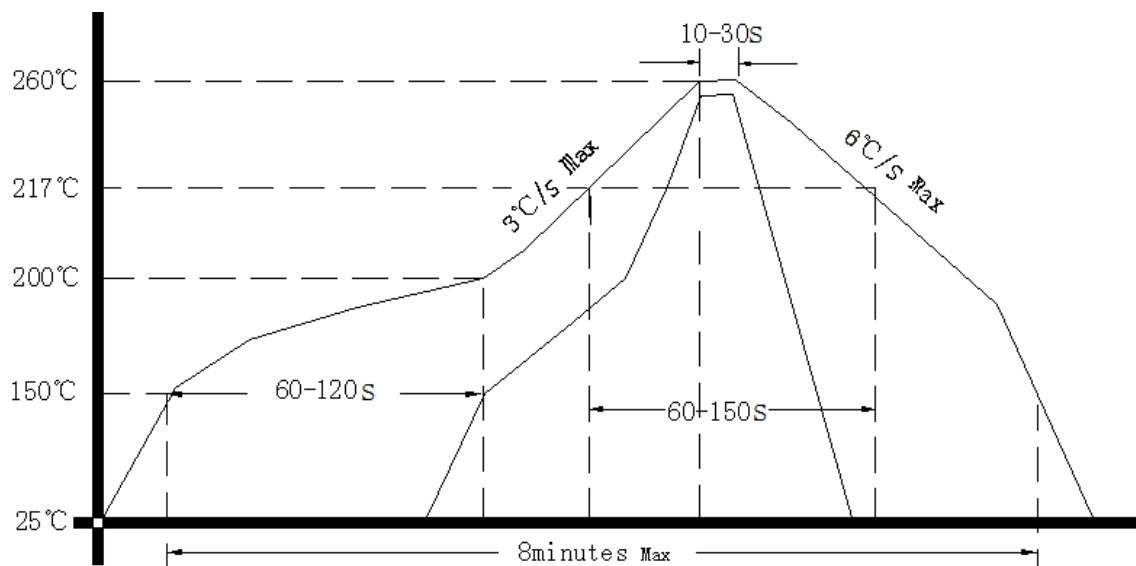

5. Package: PVC Tube,10pcs (mm)

