

Customer Code : _____

DATASHEET

DAPU P/N : **T32-B513-40.00MHz-Y**

Customer P/N: _____

DAPU			Customer Approval
Drew	Audited	Approved	Stamp, please! Thanks!
Date: 2022.02.20			

Guangdong Dapu Telecom Technology Co.,Ltd

Building 5, No.24, Industrial East Road, Songshanhu Park, Dongguan, Guangdong, P.R. China

TEL: 0086-0769-88010888 FAX: 0086-0769-81800098



1. Electrical Parameters

MODEL: T32-B513-40.00MHZ-Y						
Item	Description	Parameters			Unit	Test Condition
		Min.	Typ.	Max.		
Output	Frequency	40.00			MHz	
	Output Waveform	Clipped Sine Wave				
	V _{p-p}	0.8			V	
	Load	10KΩ//10pF				
Frequency Stabilities	Overall Stability	-4.6		+4.6	× 10 ⁻⁶	Inclusive of initial tolerance at 25°C, temperature, supply voltage ±5%, load ±5%, reflow soldering and ageing 15 years
	Frequency Tolerance vs. Operating Temperature Range	-0.28		+0.28	× 10 ⁻⁶	T _A varied from -40 to 85°C, measurement referenced to frequency observed with f _{ref} =(f _{max} +f _{min})/2, V _{cc} =3.3V, V _c =1.5V O _{load} =10KΩ//10pF, temperature variable speed less than 2°C per minute.
	Initial Frequency Tolerance	-1		+1	× 10 ⁻⁶	Measurement referenced to frequency observed with T _A =25°C, V _{cc} =3.3V, V _c =1.5V within 30 days after ex-works.
	Frequency Tolerance vs. Supply Voltage	-0.1		+0.1	× 10 ⁻⁶	measurement referenced to frequency observed T _A =25°C, V _{cc} varied from 3.13V to 3.47V, V _c =1.5V and O _{Load} =10KΩ//10pF.
	Frequency Tolerance vs. Load	-0.1		+0.1	× 10 ⁻⁶	5% load change measurement referenced to frequency observed with T _A =25°C, V _{cc} =3.3V, V _c =1.5V, O _{Load} =10KΩ//10pF.
	Aging Tolerance Per Day	-0.02		+0.02	× 10 ⁻⁶	T _A =25°C, V _{cc} =3.3V, V _c =1.5V and after 1h of operation.
	Aging Tolerance 1 Year	-1		+1	× 10 ⁻⁶	
	Power Supply	Current Consumption			3	mA
Supply Voltage		3.13	3.3	3.47	V	
Phase Noise	Phase Noise		-70	-65	dBc/Hz	10Hz
			-105	-100		100Hz
			-130	-125		1KHz
			-140	-135		10KHz
			-145	-140		100KHz



Voltage Control Characteristics	Frequency Tuning Range	-15		-10	$\times 10^{-6}$	$V_c=0.5V$. measurement referenced to $V_c=1.5V$
		-1		+1	$\times 10^{-6}$	$V_c=1.5V$. measurement referenced to exactly 40.00MHz
		+10		+15	$\times 10^{-6}$	$V_c=2.5$. measurement referenced to $V_c=1.5V$
	Linearity			10	%	
	Slope	Positive				
	Input Impedance	100			$K\Omega$	
Environmental Conditions	Operable Temperature	-40		+85	$^{\circ}C$	
	Storage Temperature	-55		+105	$^{\circ}C$	
	ESD Level	Human Body Model, class2: 2000V to 4000V; ANSI/ESDA/JEDEC JS-001-2010.				
		Machine Model, class B: 200V to 400V; JEDEC JESD22-A115C.				
	Vibration	Test Condition: 0.75mm ;acceleration:10g;10Hz~2000Hz, one cycle per 30 min, test 2 hour. (3 times for each 3 directions X , Y , Z) .IEC 68-2-06 Test Fc.				
Shock	100g; 6ms; half sine wave (3 times for each 3 directions X , Y , Z),IEC 68-2-27 Test Ea/Severity 50A.					
Full Package Storage	Relative humidity (%)	20%~70%				
	Temperature ($^{\circ}C$)	-10~35 $^{\circ}C$				



2. Mechanical Structure(mm)

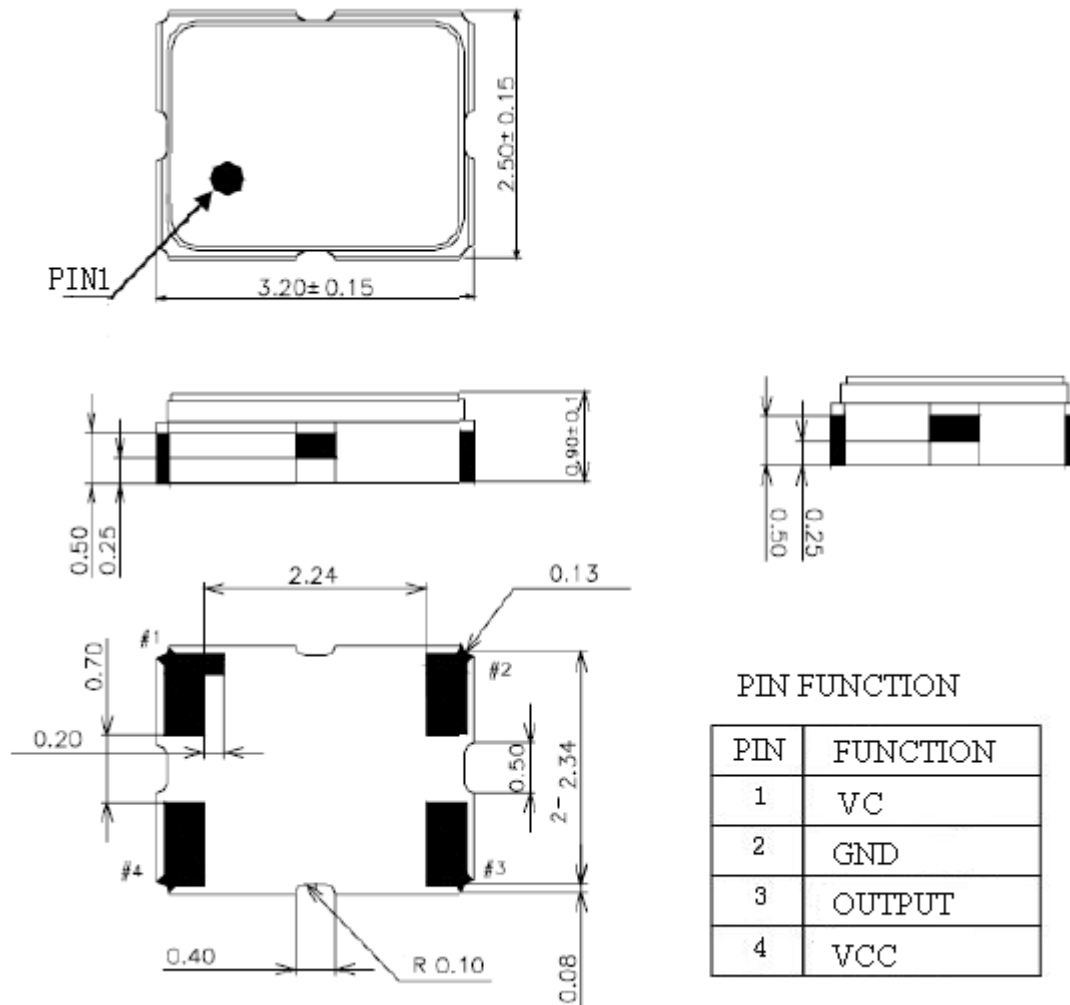

Note1: Tolerance $\pm 0.1\text{mm}$ without mark

Note2: Referential weight 0.02g

3. Test circuit

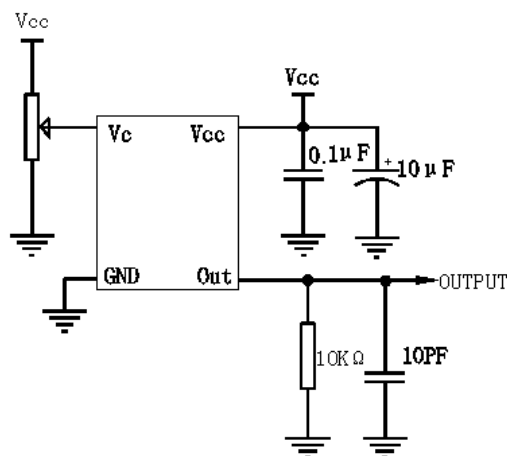



4. Reflow Soldering Curve (RoHS)

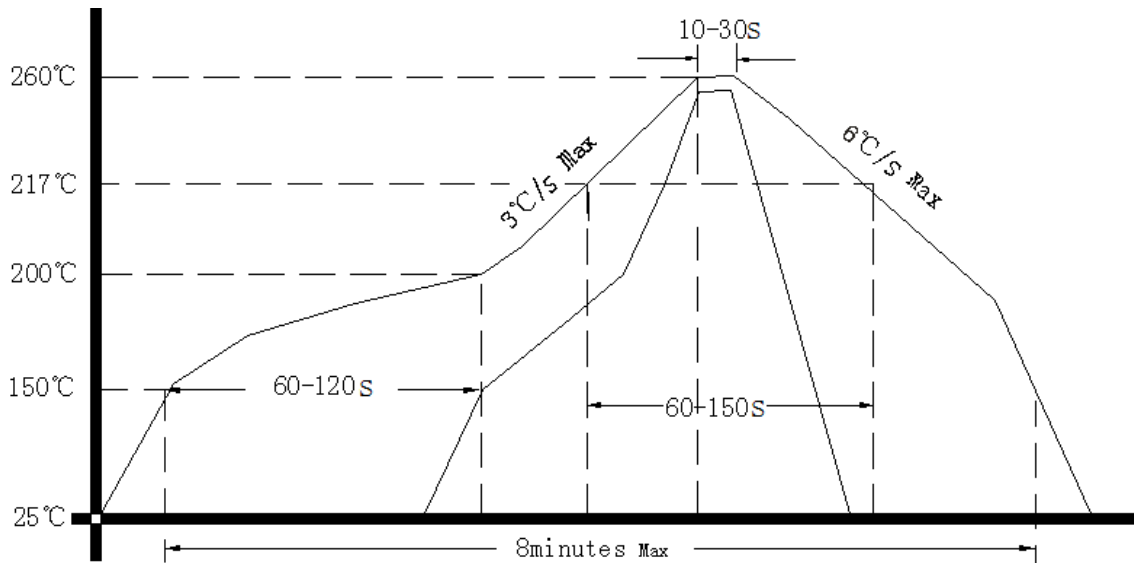

Note: If soldering with a hot air gun, ensure the temperature < 320°C , soldering time < 15 seconds.

5. Package: Tape & Reel (mm)

