

Customer Code : _____

DATASHEET

DAPU P/N: **T936-I313-38.40MHz**

Customer P/N: _____

DAPU			Customer Approval
Drew	Audited	Approved	Stamp, please! Thanks!
Date: 2024.11.21			

Guangdong Dapu Telecom Technology Co.,Ltd

Building 5, No.24, Industrial East Road, Songshanhu Park, Dongguan, Guangdong, P.R. China

TEL: 0086-0769-88010888 FAX: 0086-0769-81800098



1. Electrical Parameters

MODEL: T936-I313-38.40MHz						
Item	Description	Parameters			Unit	Test Condition
		Min.	Typ.	Max.		
Output	Frequency	38.40			MHz	
	Output Waveform	LVCMOS				
	Logic "1" Output Level	2.4			V	$V_{cc}=3.3V, O_{load}=15\text{ pF}$
	Logic "0" Output Level			0.4	V	$V_{cc}=3.3V, O_{load}=15\text{ pF}$
	Duty Cycle	48	50	52	%	@50%
	Start up time		2	3	s	
Frequency Stabilities	Frequency Tolerance vs. Operating Temperature Range	-0.28		+0.28	$\times 10^{-6}$	T_A varied from -40°C to 90°C , measurement referenced to frequency observed with $f_{ref}=(f_{max}+f_{min})/2, V_{cc}=3.3V, V_c=1.65V, O_{load}=15\text{ pF}$, temperature variable speed less than 2°C per minute.
	Initial Frequency Tolerance	-1.5		+1.5	$\times 10^{-6}$	Measurement referenced to frequency observed with $T_A=25^\circ\text{C}, V_{cc}=3.3V, V_c=1.65V$ within 30 days after ex-works.
	Frequency Tolerance vs. Supply Voltage	-0.1		+0.1	$\times 10^{-6}$	measurement referenced to frequency observed $T_A=25^\circ\text{C}, V_{cc}$ varied from 3.13V to 3.47V, $V_c=1.65V$ and $O_{Load}=15\text{ pF}$.
	Phase Jitter		600		fs	12Hz to 20MHz
	Aging Tolerance 1 Year	-1		+1	$\times 10^{-6}$	$T_A=25^\circ\text{C}, V_{cc}=3.3V, V_c=1.65V$ and after 1h of operation.
	Aging Tolerance 10 Year	-3		+3	$\times 10^{-6}$	
Power Supply	Input Current			50	mA	@ $25^\circ\text{C}, V_{cc}=3.3V, V_c=1.65V, O_{load}=15\text{ pF}$.
	Supply Voltage	3.13	3.3	3.47	V	



Voltage Control Characteristics	Frequency Tuning Range	-10		-5	$\times 10^{-6}$	$V_c=0V$. measurement referenced to $V_c=1.65V$
		-1.5		+1.5	$\times 10^{-6}$	$V_c=1.65V$. measurement referenced to exactly 38.40MHz
		+5		+10	$\times 10^{-6}$	$V_c=3.3V$. measurement referenced to $V_c=1.65V$
	Deviation Slope	Monotonic Positive				
	Input Impedance	10			K Ω	
Phase Noise	Phase Noise			-80	dBc/Hz	10Hz
				-108		100Hz
				-134		1KHz
				-149		10KHz
				-155		100KHz
				-155		1MHz
Environmental Conditions	Operable Temperature	-40		+90	$^{\circ}C$	
	Storage Temperature	-55		+105	$^{\circ}C$	
	ESD Level	Human Body Model, class2: 2000V to 4000V; ANSI/ESDA/JEDEC JS-001-2010.				
		Machine Model, class B: 200V to 400V; JEDEC JESD22-A115C.				
	Moisture Sensitivity Level	Level 3.				
	Vibration	Test Condition: 0.75mm ;acceleration:10g;10Hz~2000Hz, one cycle per 30 min, test 2 hour. (3 times for each 3 directions X , Y , Z) .IEC 68-2-06 Test Fc.				
Shock	100g; 6ms; half sine wave (3 times for each 3 directions X , Y, Z),IEC 68-2-27 Test Ea/Severity 50A.					
Full Package Storage	Relative humidity (%)	20% ~ 70%				
	Temperature ($^{\circ}C$)	-10~35 $^{\circ}C$				



2. Mechanical Structure(mm)

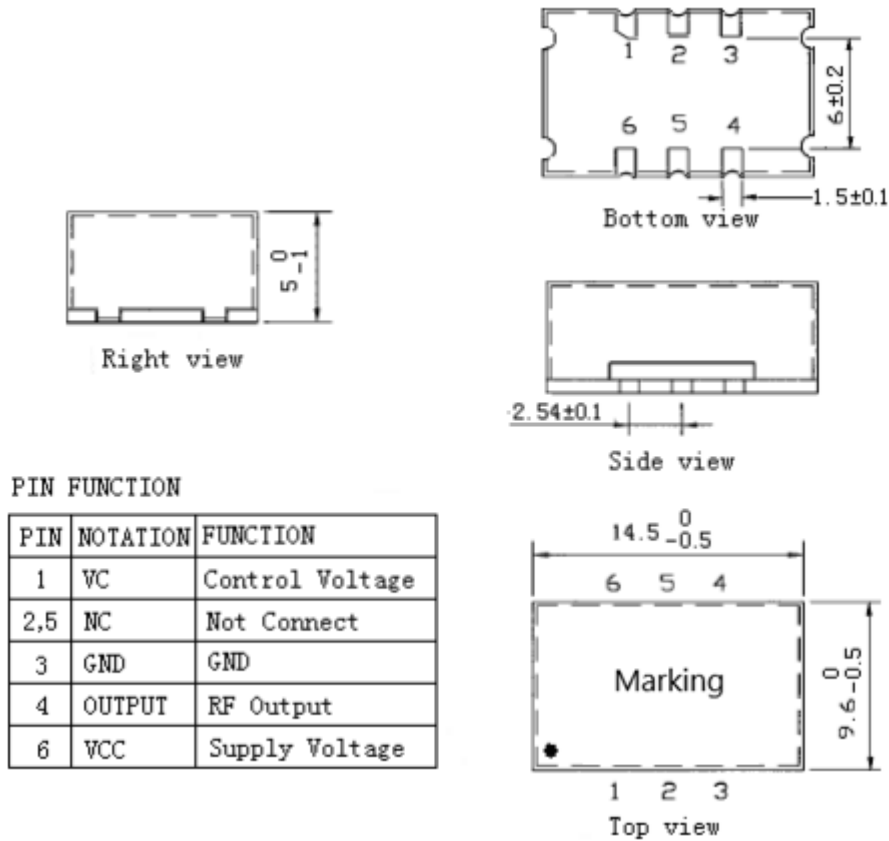

PIN FUNCTION

PIN	NOTATION	FUNCTION
1	VC	Control Voltage
2,5	NC	Not Connect
3	GND	GND
4	OUTPUT	RF Output
6	VCC	Supply Voltage

Marking:



- Note1:** Tolerance ± 0.2 mm without mark
- Note2:** The first two xx representative: year
After two xx representative: week
- Note3:** Referential weight 2.0g
- Note4:** NC is not connect



3. Test circuit

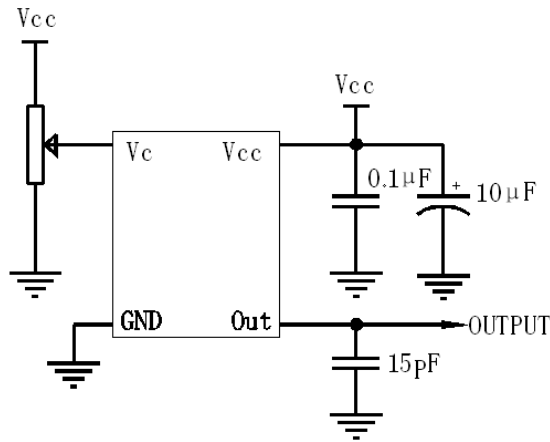

4. Reflow Soldering Curve (RoHS)

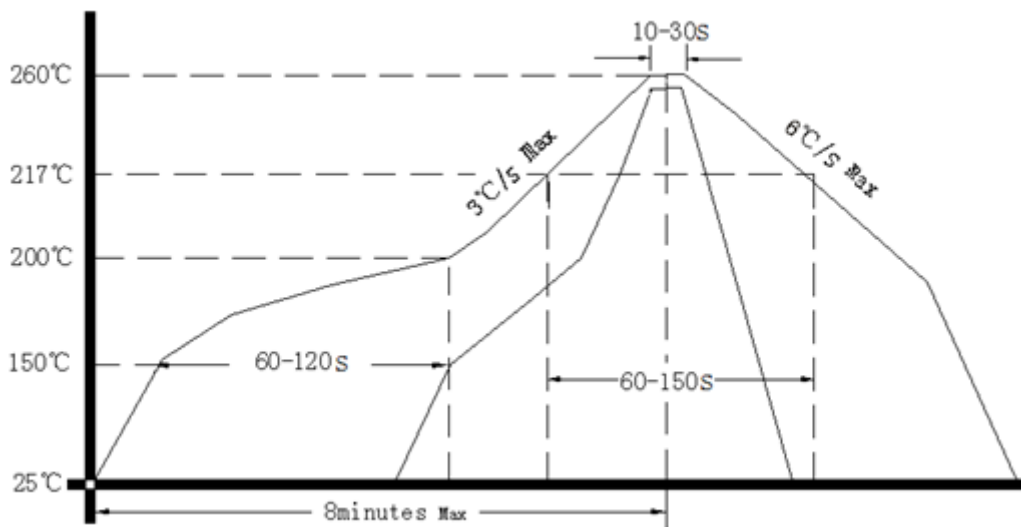

5. Package: Tape & Reel (mm)

