

Travelling Merchant: _____

DATASHEET

Standard: CM55F-K119-10.00MHzP/N: CM-0024

Plot			The Label
Drew	Audited	Approved	Stamp, please! Thanks!
Date: 2024.08.28			

Guangdong Dapu Telecom Technology Co.,Ltd

Building 5, No.24, Industrial East Road, Songshanhu Park, Dongguan, Guangdong, P.R. China

TEL: 0086-0769-88010888 FAX: 0086-0769-81800098



Table of amendment

Version	Revision contents	Prepared by	Revised date
1.0	The first issued	<i>Amway</i>	2011.06.22
1.1	Added "Aplication Information"	<i>Amway</i>	2012.04.06
1.2	Supplement Pin definitions	<i>Amway</i>	2013.05.17
1.3	"Holdover Capability-Test Condition", "Pulse Width", "Phase Noise", "Environmental Conditions", "Mechanical Structure", "Coding Rules" change	<i>Amway</i>	2014.04.19
1.4	Add "Frequency Tolerance vs. Operating Temperature Range" The "Marking" changed	<i>Amway</i>	2024.06.12
1.5	"Mechanical Structure" changed	<i>Amway</i>	2024.07.01
1.6	"Frequency Tolerance vs. Operating Temperature Range" changed	<i>Amway</i>	2024.08.28



1. Electrical Parameters

Parameters	Min.	Typ.	Max.	Unit.	Test Condition	
	HCMOS					
1 PPS Reference Input	Waveform	HCMOS				50Ω
	High-Level Input Voltage (V _{IH})	2.7			V	
	Low-Level Input Voltage (V _{IL})			0.4	V	
	Pulse Width	10			μs	
	Connector	Pin 10				
State Input	Parameters	Min.	Typ.	Max.	Unit.	Test Condition
	Lock	2.7			V	<5mA Load
	Holdover			0.4	V	<5mA Load
	Connector	Pin 8				
RF Output	Parameters	Min.	Typ.	Max.	Unit.	Test Condition
	Nominal Frequency	10.00			MHz	
	Waveform	Sine wave				
	Level	6		10	dBm	
	Load	50			Ω	
	Harmonics Suppression			-30	dBc	
	Spurious Suppression			-60	dBc	
	Frequency Tolerance vs. Operating Temperature Range	-0.2		+0.2	×10 ⁻⁹	TA varied from -40°C to 85°C, measurement referenced to frequency observed with f _{ref} =(f _{max} +f _{min})/2, V _{cc} =3.3V, O _{load} =50Ω, temperature variable speed less than 2°C per minute.
	Accuracy	-1		+1	×10 ⁻¹²	24 hours average when locked to 1 PPS
	Short-term Stability			0.02	×10 ⁻⁹	Temperature stability, no EMI\EMC or other interference, test after power for 1 hour ref. to 25°C; 1s.
	Aging Tolerance Per Day	-0.2		+0.2	×10 ⁻⁹	V _{cc} , T _A constant measurement referenced to frequency observed with T _A =25°C, V _{cc} =5.0V, in FREE RUN condition and after 30 days of operation.
	Aging Tolerance 1 Year	-0.01		+0.01	×10 ⁻⁶	
	Phase Noise (All conditions)		-118	-108	dBc/Hz	10Hz
		-138	-128	100Hz		



			-148	-143		1KHz
			-150	-145		10KHz
			-150	-145		100KHz
			-150	-145		1MHz
	Connector	Pin 14				
Holdover Capability	Holdover Time	Min.	Typ.	Max.	Unit.	Test Condition
	24 Hours	-1.5		+1.5	μs	ΔT=±2°C, 24 hours holdover after turn on 7days and lock 3days. Temperature variable speed less than 1°C per minute
Supply Voltage	Parameters	Min.	Typ.	Max.	Unit.	Test Condition
	Supply Voltage	4.75	5.0	5.25	V	
	Current Consumption			1400	mA	During Warm-up
				600	mA	During steady state operation @25°C
	AC Ripple			50	mVpk-pk	10Hz to 1MHz
	Connector	Pin 3				
1 PPS Output Waveform Characteristics	Parameters	Min.	Typ.	Max.	Unit.	Test Condition
	Waveform	HCMOS				
	High-Level Output Voltage(V _{OH})	2.7			V	50Ω
	Low-level Output voltage (V _{OL})			0.4	V	
	Pulse Width	10			μs	
	Connector	Pin 12				
State Output	Parameters	Min.	Typ.	Max.	Unit.	Test Condition
	Lock	2.7			V	<5mA Load
	Holdover			0.4	V	<5mA Load
		Connector	Pin 5			
Serial Interfaces	Parameters	Min.	Typ.	Max.	Unit.	Test Condition
	Rx high-level Input Voltage (V _H)	2.7			V	
	Rx low-level Input Voltage (V _L)			0.4	V	
	Tx high-level Output Voltage (V _H)	2.7			V	
	Tx low-level Output Voltage (V _L)			0.4	V	
	Serial Protocol	9600-N-8-1				



	Connector	Pin6 and Pin7	
Environmental Conditions	Parameter	Conditions	
	Operating Temperature	-40°C to 85°C	
	Storage Temperature	-55°C to 105°C	
	Storage Humidity	30%~80%	
	ESD Level	Human Body Model, class2: 2000V to 4000V; ANSI/ESDA/JEDEC JS-001-2010.	
		Machine Model, class B: 200V to 400V; ANSI/ESDA/JEDEC JS-001-2010.	
	Moisture Sensitivity Level	Not humidity sensitive.	
	Vibration	Test Condition: 0.75mm ;acceleration:10g;10Hz~500Hz, one cycle per 30 min, test 2 hours. (3 times for each 3 directions X , Y , Z), IEC 68-2-06 Test Fc.	
Shock	50g; 11ms; half sine wave (3 times for each 3 directions X , Y , Z),IEC 68-2-27 Test Ea/Severity 50A.		



2、Mechanical Structure(mm)

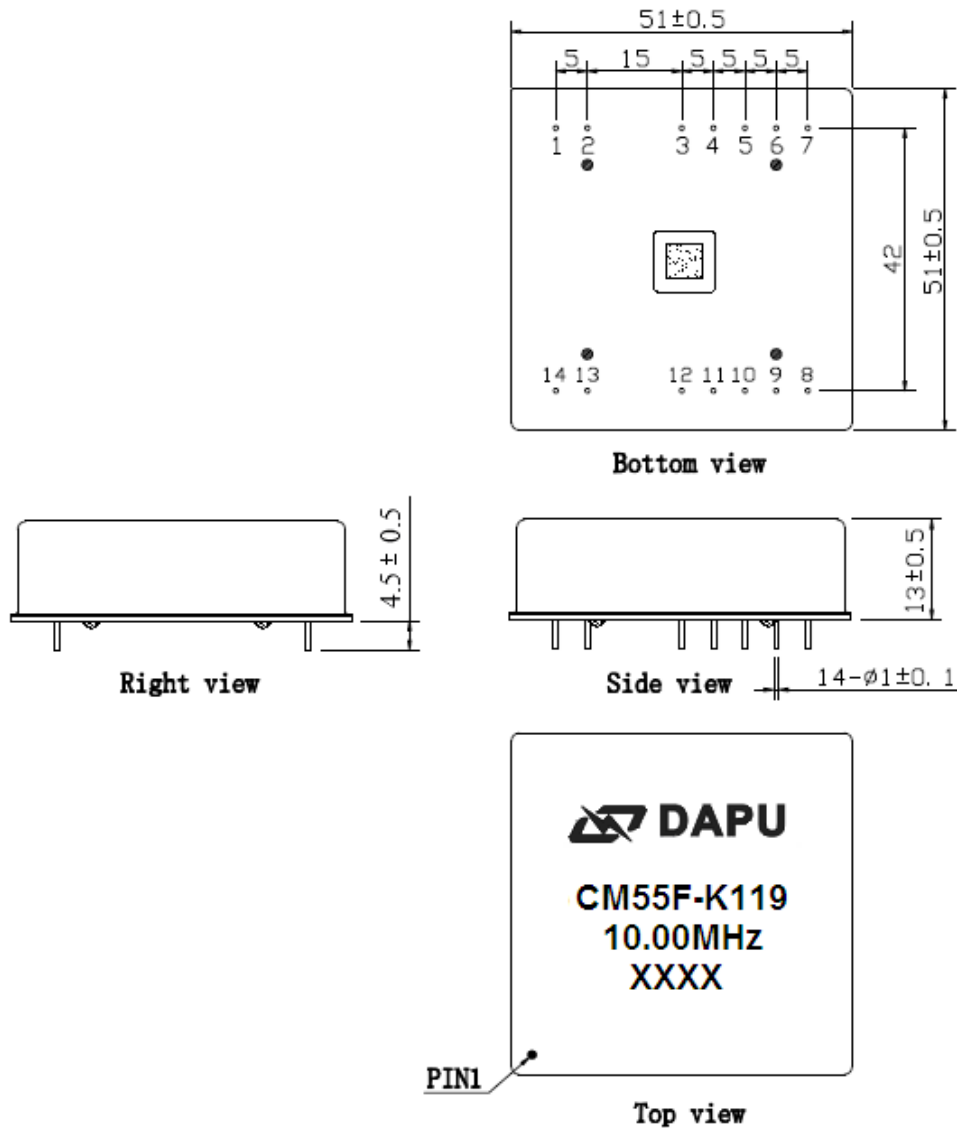

Note1: Tolerance ± 0.2 mm without mark

Note2: The first two xx representative: year
After two xx representative: week

Note3: Referential Weight 52 ± 5 g



PIN DEFINITION			
PIN	NAME	DESCRIPTION	
3	VCC	Power supply input, 4.75V to 5.25V.	
5	State OUTPUT	State output. Output high level when the CM is locked and stable, others low level.	
6	RX INPUT	Asynchronous serial data input. 9600-N-8-1.	
7	TX OUTPUT	Asynchronous serial data output.9600-N-8-1.	
8	State INPUT	H: Lock	The work state is set to normal operation when the state input is high.
		L: Holdover	The work state is set to hold over when the state input is low.
10	PP1S INPUT	PP1S reference input.	
12	PP1S OUTPUT	The clock module PP1S output .	
14	10MHz OUTPUT	10MHz OCXO frequency output .	
1、2、9	NC	Not connected.	
4、11、13	GND	GND	

3、 Functional Block Diagram

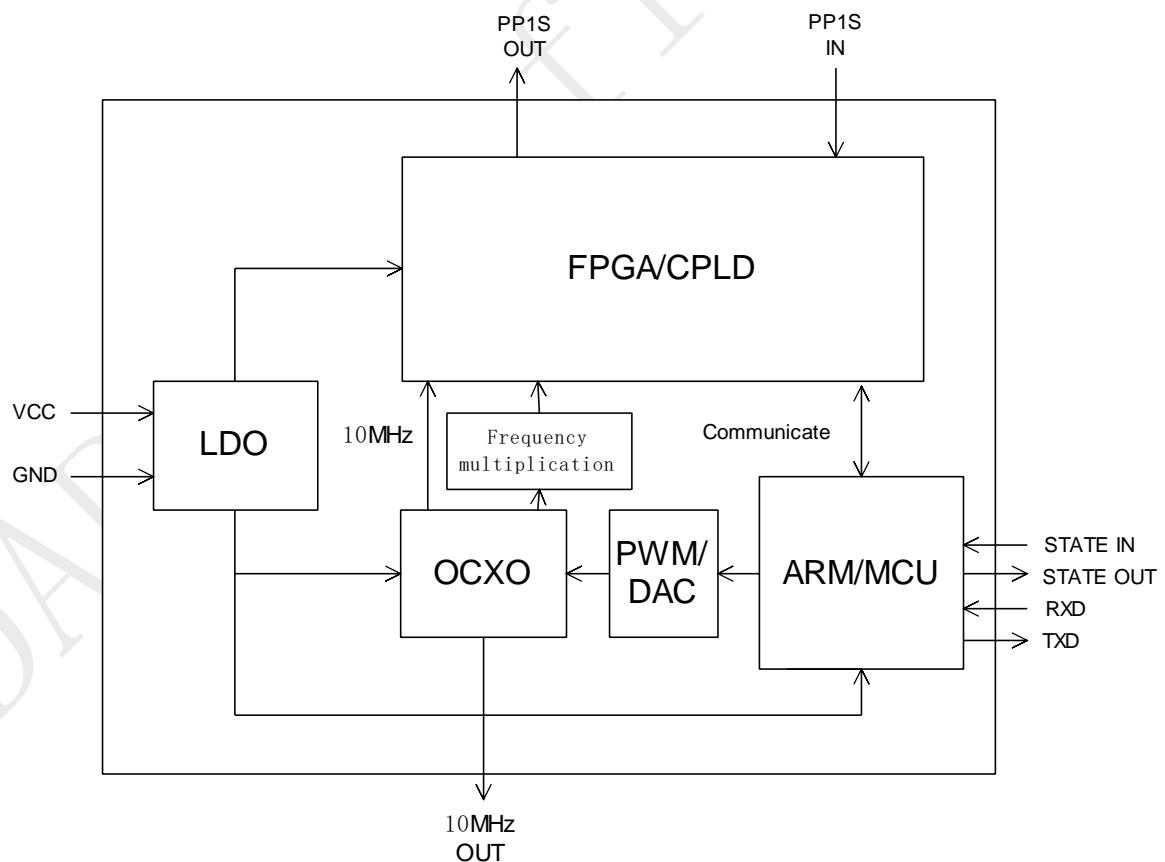



4、 Workflow Diagram

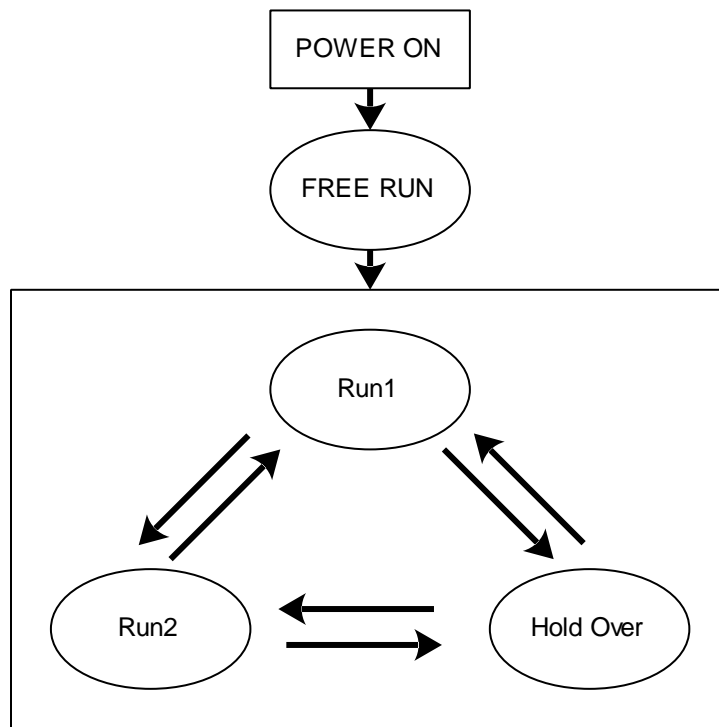

- Run1: Fast track. Adjust the OCXO 10MHz output frequency quickly to track the PP1S of 10MHz with PP1S reference.
- Run2: Slow track. Adjust the OCXO 10MHz output frequency slowly when the phase error is in the define range.
- Hold Over: GPS PP1S reference miss, an algorithm has been developed which enables adaptive modeling of the frequency stability of an OCXO with reference to a GPS timing signal.
- Free Run: Clock module power on without 1PPS reference anyway.



5、 The Product Test Output Message

Example:

\$PDP,00,0,F,Q,-3095,32768.0000,32768.0000,000,000,00000.0000,00000.0000,00000.0000,00000.0000,3-23,+000.0000,-000,www.dptel.com,1.1,2011-05-16*55

Notes:

In the Format column, c stand for char ,d stand for digit, s stand for sign.

Field No.	Name	Format	Description	Length (byte)
0	\$PDP	\$ccc	Message ID, DAPU Telecom Technology protocol header	4
1	No	dd	Message No.	2
2	TxRxFlag	d	The transmit and receive flag.(0: upper computer transmit; 1: upper computer receive)	1
3	CStatus	c	Current status.(F: warm-up; L: Lock; H: Hold over)	1
4	TrackStatus	d	Track status (Q: fast track;S: slow track)	1
5	cPHDiff	sdddd	Current phase difference	5
6	cPWM1	dddd.dddd	Current PWM1 (Voltage-controlled value1)	10
7	cPWM2	dddd.dddd	Current PWM2 (Voltage-controlled value2)	10
8	SYNCNT	ddd	The synchronous times	3
9	HCNT	ddd	Hours after enter slow track	3
10	HPAVG	dddd.dddd	The average of the PWM in the last 1 hour	10
11	VCH1	dddd.dddd	Voltage-controlled compensation value every 1 hour	10
12	HPMOD	dddd.dddd	The Module PWM Value	
13	VCM10	dddd.dddd	Voltage-controlled compensation value every 10 minutes	10
14	POS	d-dd	The position of the product.(Layer-No), just for the inner test.	4
15	inT	sddd.dddd	NA	9
16	TcPHDiff	sdddd	The product current phase difference	5
17	Website		www.dptel.com	13
18	Version	d.d	version	3
19	Date	dddd-dd-dd	Date	10
20		dd	55	2
21	END		<CR><LF>	2



6、Aplication Information

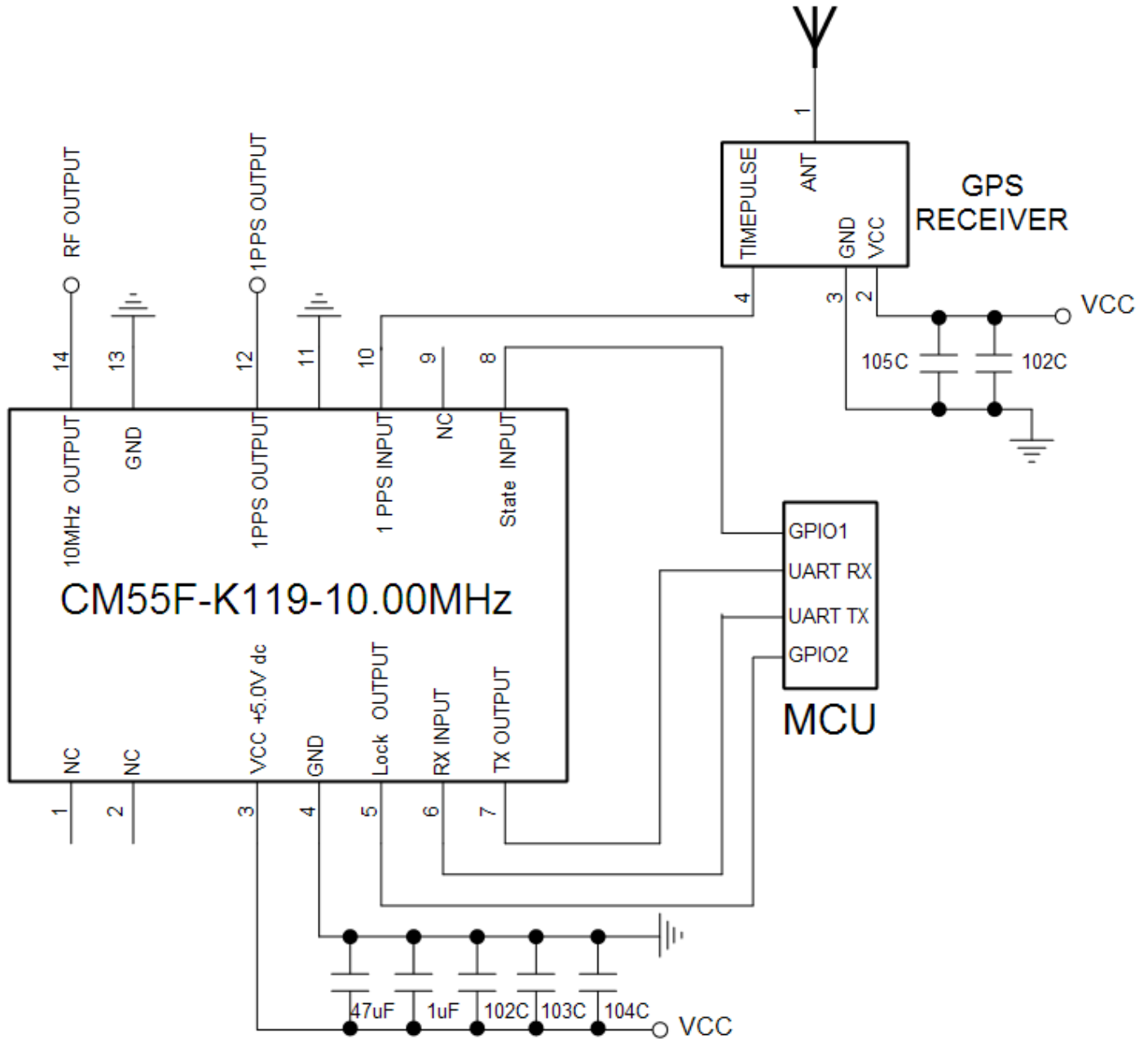

GPS RECEIVER supplies 1PPS signal to the clock module CM55F.

The MCU Monitors the work state of CM55F.

The CM55F is operated with a supply of 5V.

Note1: Power on more than seven days is necessary for the OCXO drift fast in the first four days.

Note2: The adptive model can be built with at least two days good GPS signal. Every time power off will lose the model.

Note3: The work state is set to hold over when the state input is low, no matter the GPS PP1S effective or not.



7、 Coding Rules

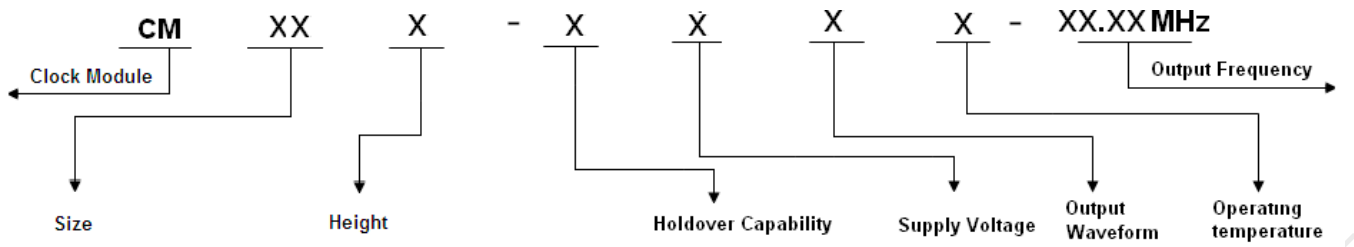

Size	Height	Holdover Capability	Supply Voltage	Output Waveform	Operating temperature
55 50×50 (mm)	A 19mm, single Freq, external GPS receiver	A ±1.5μs 0°C~60°C 24hours	1 5.0V	1 Sine Wave 2 HCMOS	1 0°C~80°C 2 -10°C~70°C 9 -20°C~75°C
66 60×60 (mm)	B 19mm, single Freq, internal GPS receiver	B ±3.0μs 0°C~60°C 24hours			
65 65×65 (mm)	C 19mm, single Freq, internal dual-mode receiver	C ±8.0μs 0°C~60°C 24hours	1 5.0V	1 Sine Wave 2 HCMOS	1 0°C~80°C 2 -10°C~70°C 9 -20°C~75°C
	D 13mm, single Freq, external GPS receiver	D ±1.5μs ΔT=±5°C 24hours			
	G 13mm, single Freq, internal GPS receiver	E ±3.0μs ΔT=±5°C 24hours			
	H 13mm, dual-Freqs, internal GPS receiver	F ±8.0μs ΔT=±5°C 24hours			
	K 13mm, single Freq, internal dual-mode receiver	G ±1.5μs ΔT=±5°C 8hours			
	L 13mm, dual-Freqs, internal dual-mode receiver	H ±3.0μs ΔT=±5°C 8hours			
		I ±8.0μs ΔT=±5°C 8hours			
		K ±1.5μs ΔT=±2°C 24hours			
	M ±3.0μs ΔT=±2°C 24hours				
	N ±8.0μs ΔT=±2°C 24hours				
	O ±1.5μs ΔT=±2°C 8hours				
	P ±3.0μs ΔT=±2°C 8hours				
	Q ±8.0μs ΔT=±2°C 8hours				

8、 Reflow Soldering Curve (RoHS)

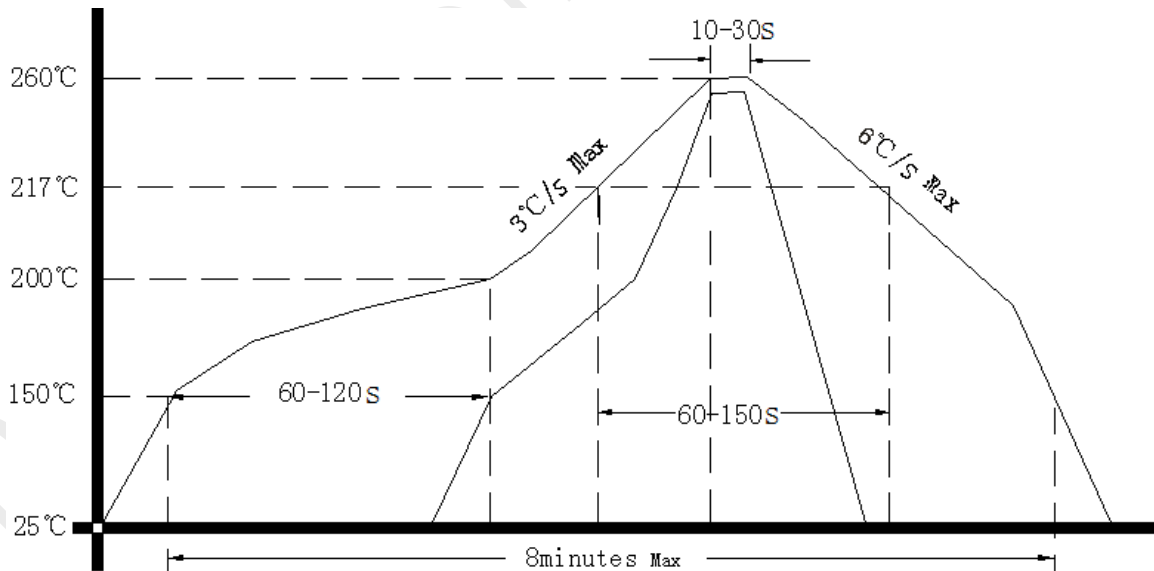



9、Package (mm)

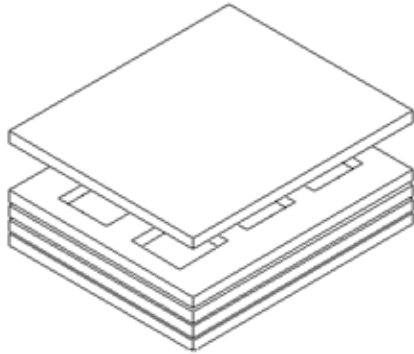

Buffer material

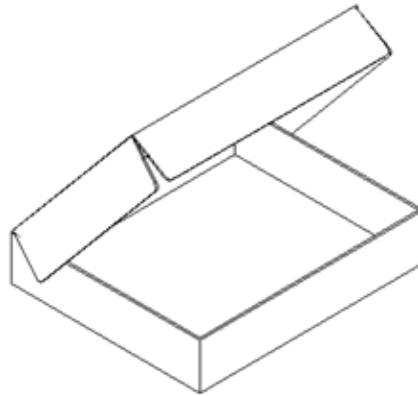

Cardboard
Max 6pcs. circulator

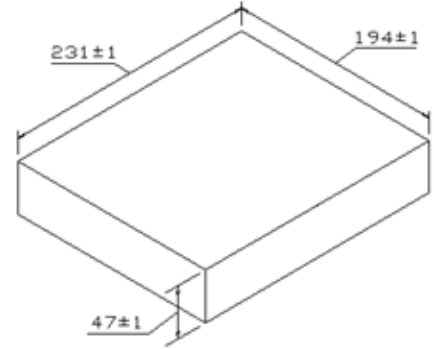

DAPU Confidential