

**Customer Code:** \_\_\_\_\_

# DATASHEET

**DAPU P/N:** DPX0232K7680125A101

<b>DAPU</b>			<b>Customer Approval</b>
Drew	Audited	Approved	
Jieshu ZHENG	Jianhua LIN	Gangtao FENG	
Date: 2024/7/2			
			Stamp, please! Thanks!

## Guangdong Dapu Telecom Technology Co.,Ltd

Bldg 5, SSL Modern Enterprise Accelerator Zone, Dongguan City, Guangdong Province, PRC China  
TEL: 0086-0769-88010888 FAX: 0086-0769-81800098



## 1、Electrical Parameter

MODEL :		DPX0232K7680125A101					
No.	Parameters	SYM.	Electrical Spec.				Notes
			Min.	Typ.	Max.	Units	
1	Specification	-	2012			-	
2	Nominal Frequency	FL	32.768			KHz	
3	Oscillation Mode	-	Fundamental			-	
4	Load Capacitance	CL	12.5			pF	
5	Frequency Tolerance	-	-20		20	$\times 10^{-6}$	At 25°C (Not include aging)
6	Turnover Temperature	-	25±5			°C	
7	Operating Temperature	Topr	-40		105	°C	
8	Storage Temperature	Tstg	-40		125	°C	
9	Drive Level	DL			0.5	$\mu$ W	
10	Equivalent Series Resistance	ESR			60	K $\Omega$	
11	Parabolic Coefficient	-			-0.040	ppm/°C <sup>2</sup>	
12	Insulation Resistance	IR	500			M $\Omega$	At DC 100V±15V
13	Shunt Capacitance	-		1.6		pF	
14	Standard	-				-	

## 2、 Dimension drawing (Unit: mm)

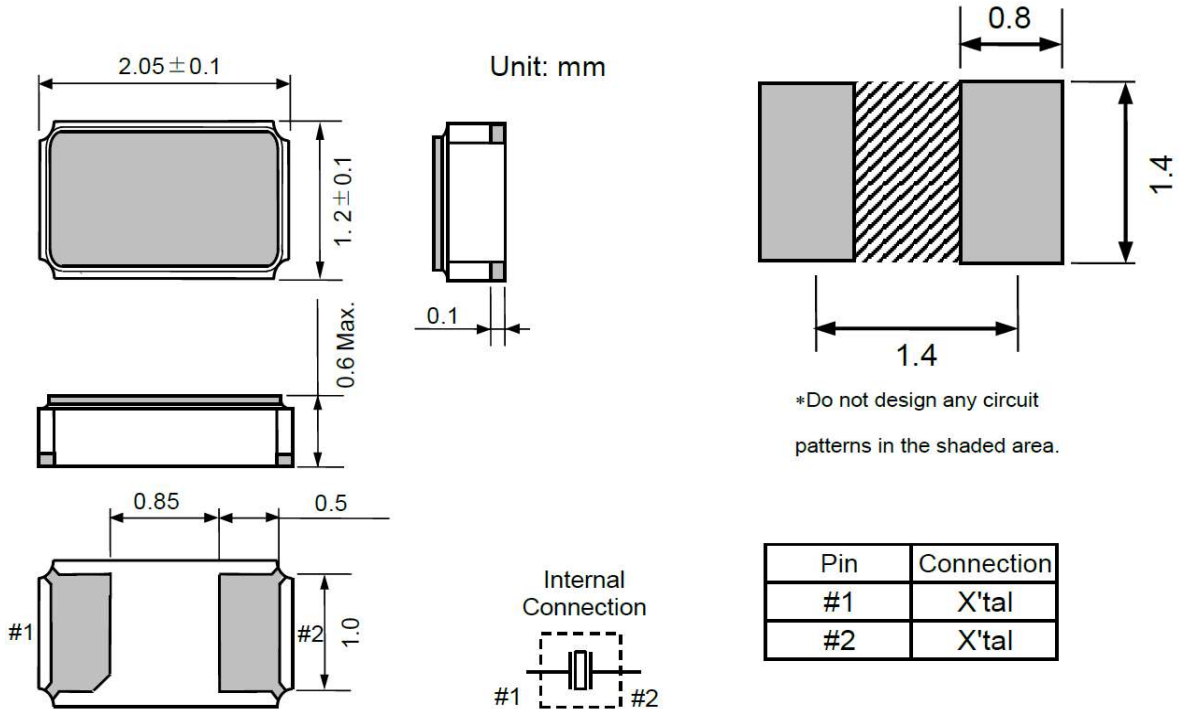

## 3、 Marking

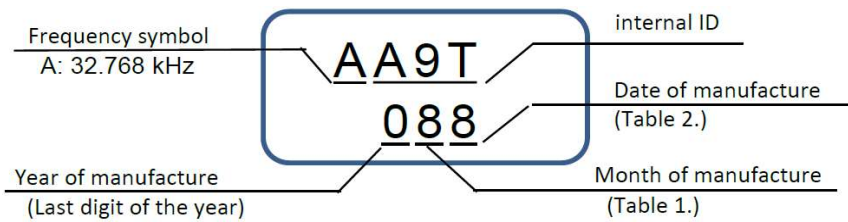

Table 1. Month of manufacture

Month	Jan	Feb	Mar	Apr	May	Jun	Jul	Aug	Sep	Oct	Nov	Dec
Code	1	2	3	4	5	6	7	8	9	X	Y	Z

Table 2. Date of manufacture

Date	1st	2nd	3rd	4th	5th	6th	7th	8th	9th	10th	11th	12th
Code	1	2	3	4	5	6	7	8	9	A	B	C
Date	13th	14th	15th	16th	17th	18th	19th	20th	21st	22nd	23rd	24th
Code	D	E	F	G	H	J	K	L	M	N	P	Q
Date	25th	26th	27th	28th	29th	30th	31st					
Code	R	S	T	U	V	W	X					

### 4、 Reflow soldering

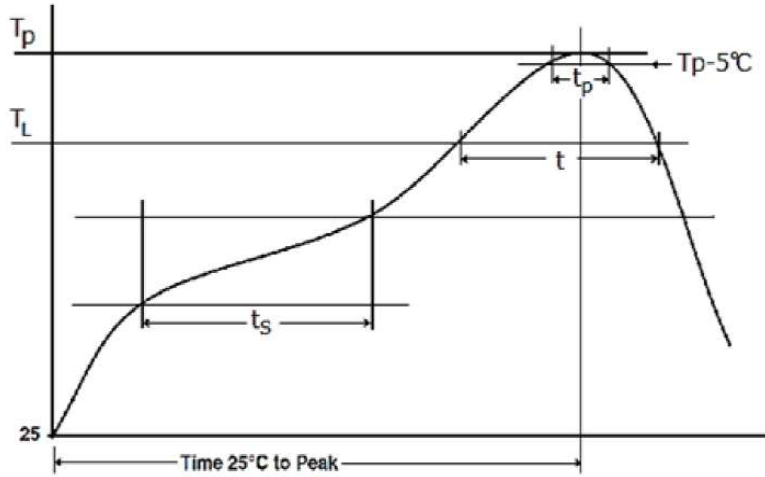

ts	(°C)	150~200
ts time	(s)	60~120
TL	(°C)	217
t time	(s)	60~150
Tp	(°C)	max. 260
tp	(s)	max. 30

### 5、 Package: Tape & Reel (mm)

