

Customer Code : \_\_\_\_\_

# DATASHEET

DAPU P/N: 022A-J425-40.00MHz

Customer P/N: \_\_\_\_\_

DAPU			Customer Approval
Drew	Audited	Approved	Stamp, please! Thanks!
Date: 2023.11.07			

## Guangdong Dapu Telecom Technology Co.,Ltd

Building 5, No.24, Industrial East Road, Songshanhu Park, Dongguan, Guangdong, P.R. China

TEL: 0086-0769-88010888 FAX: 0086-0769-81800098



### Table of amendment

Version	Revision contents	Prepared by	Revised date
1.0	The first issued	<i>Amway</i>	2023.10.16
1.1	The “Aging” “Reference Voltage” “Voltage Control” changed	<i>Amway</i>	2023.11.07



## 1. Electrical Parameters

MODEL: O22A-J425-40.00MHz						
Item	Description	Parameters			Unit	Test Condition
		Min.	Typ.	Max.		
Output	Frequency	40.00			MHz	
	Output Waveform	Sine wave				
	Level	5			dBm	
	Load	50			$\Omega$	
	Harmonics Suppression			-35	dBc	
	Spurious Suppression			-80	dBc	
Frequency Stabilities	Frequency Tolerance vs. Operating Temperature Range	-0.01		+0.01	$\times 10^{-6}$	$T_A$ varied from $-40^{\circ}\text{C}$ to $85^{\circ}\text{C}$ , measurement referenced to frequency observed with $f_{\text{ref}}=(f_{\text{max}}+f_{\text{min}})/2$ , $V_{\text{cc}}=5.0\text{V}$ , $O_{\text{load}}=50\Omega$ , temperature variable speed less than $2^{\circ}\text{C}$ per minute.
	Initial Frequency Tolerance	-0.5		+0.5	$\times 10^{-6}$	Measurement referenced to frequency observed with $T_A=25^{\circ}\text{C}$ , $V_{\text{cc}}=5.0\text{V}$ , $V_c=2.25\text{V}$ and after 30 minutes of operation, within 30 days after ex-works.
	Frequency Tolerance vs. supply voltage	-5		+5	$\times 10^{-9}$	measurement referenced to frequency observed $T_A=25^{\circ}\text{C}$ , $V_{\text{cc}}$ varied from 4.75V to 5.25V, $V_c=2.25\text{V}$ , $O_{\text{load}}=50\Omega$ .
	Frequency Tolerance vs. Load	-5		+5	$\times 10^{-9}$	5% Load Change Measurement referenced to frequency observed with $T_A=25^{\circ}\text{C}$ , $V_{\text{cc}}=5.0\text{V}$ , $V_c=2.25\text{V}$ , $O_{\text{load}}=50\Omega$ .
	Short Term Stability			0.05	$\times 10^{-9}$	Temperature stability, no EMI\EMC or other interference, test after power for 1hour ref. to $25^{\circ}\text{C}$ ; 1s.
	Aging Tolerance per day	-3		+3	$\times 10^{-9}$	$V_{\text{cc}}, V_c, T_A$ constant Measurement referenced to frequency observed with $T_A=25^{\circ}\text{C}$ ,
	Aging Tolerance 1Year	-0.1		+0.1	$\times 10^{-6}$	$V_{\text{cc}}=5.0\text{V}, V_c=2.25\text{V}, O_{\text{load}}=50\Omega$ and after 30 days of operation.
Power Supply	Supply Voltage	4.75	5.0	5.25	V	
	Reference Voltage	4.28	4.5	4.72	V	
	Current Consumption			250	mA	@ $25^{\circ}\text{C}$
	Current Consumption during warm up			700	mA	
	Warm-Up Time			5	minutes	@ $25^{\circ}\text{C}$ within $\pm 0.1 \times 10^{-6}$ of final frequency with reference after 1hour on.



Voltage Control Characteristics	Frequency Tuning Range			-1	$\times 10^{-6}$	$V_c=0V$ . measurement referenced to $V_c=2.25V$ .
		-0.5		+0.5	$\times 10^{-6}$	$V_c=2.25V$ . measurement referenced to exactly 40.00MHz.
		+1			$\times 10^{-6}$	$V_c=4.5V$ . measurement referenced to $V_c=2.25V$ .
	Linearity			10	%	
	Slope	Positive				
	Input Impedance	100				K $\Omega$
Phase Noise	Phase Noise @25°C			-105	dBc/Hz	10Hz
				-141		100Hz
				-160		1KHz
				-165		10KHz
				-165		100KHz
				-165		1MHz
Environmental Conditions	Operable Temperature	-40		+85	°C	
	Storage Temperature	-55		+105	°C	
	ESD Level	Human Body Model, class2: 2000V to 4000V; ANSI/ESDA/JEDEC JS-001-2010.				
		Machine Model, class B: 200V to 400V; JEDEC JESD22-A115C.				
	Moisture Sensitivity Level	Not humidity sensitive.				
	Vibration	Test Condition: 0.75mm ;acceleration:10g;10Hz~500Hz, one cycle per 30 min, test 2 hour. (3 times for each 3 directions X , Y , Z), IEC 68-2-06 Test Fc.				
Shock	50g; 11ms; half sine wave (3 times for each 3 directions X, Y, Z), IEC 68-2-27 Test Ea/Severity 50A.					
Full Package Storage	Relative humidity (%)	20% ~70%				
	Temperature (°C)	-10~35°C				



## 2. Mechanical Structure (mm)

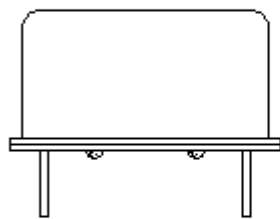
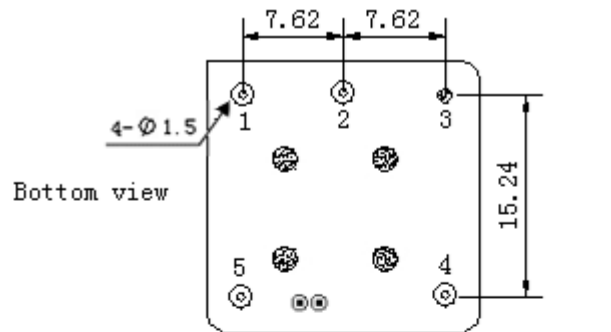

Right view

Side view

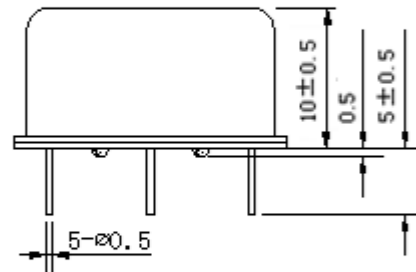

PIN FUNCTION

PIN	NOTATION	FUNCTION
1	VC	Control Voltage
2	VREF	Reference Voltage
3	GND	GND
4	OUTPUT	RF Output
5	VCC	Supply Voltage

Top view

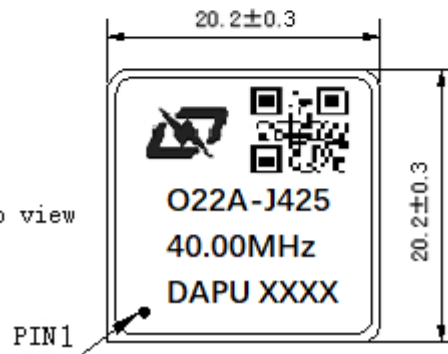

**Note1:** Tolerance  $\pm 0.2$ mm without mark

**Note2:** The first two xx representative: week  
After two xx representative: year

**Note3:** Referential Weight 8.0g



### 3. Test Circuit

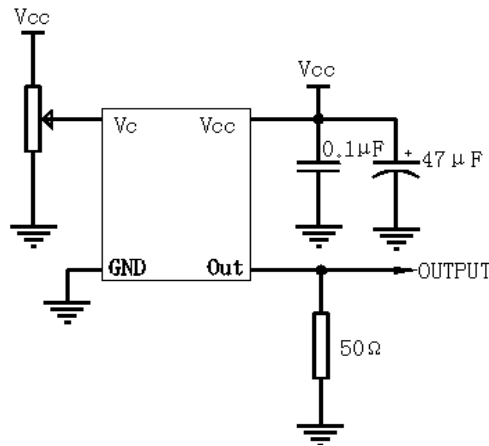

### 4. Reflow Soldering Curve (RoHS)

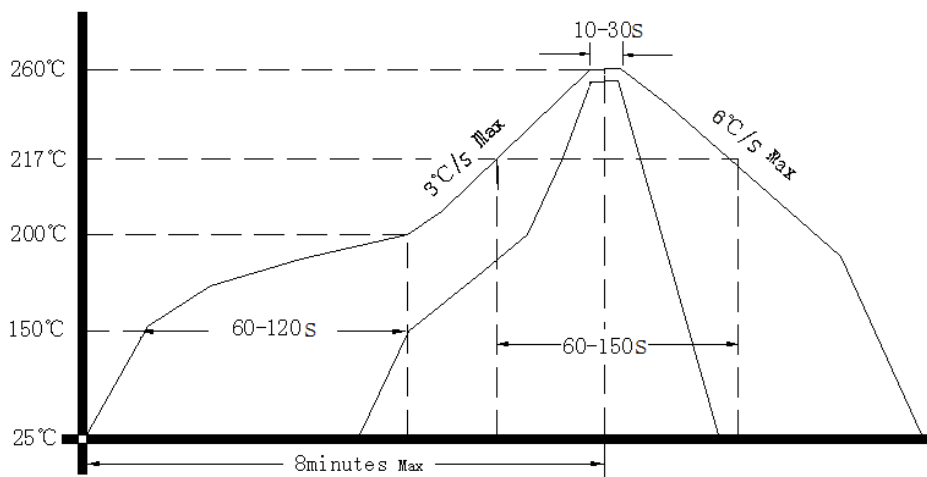

### 5. Package(mm)

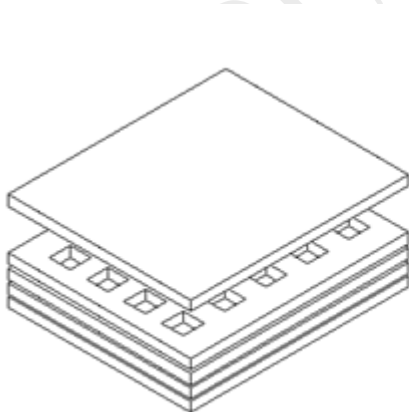

Buffer material

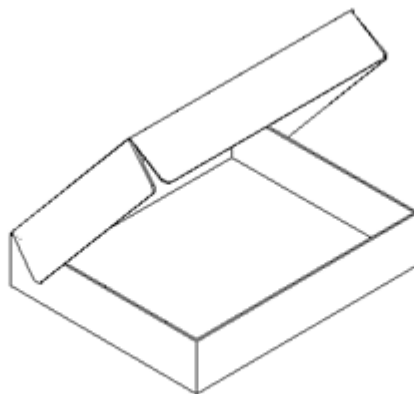

Cardboard  
Max 20pcs. circulator

