

Travelling Merchant: A008

# DATASHEET

Standard: T53-0802-20.00MHz

P/N: \_\_\_\_\_

Plot			The Label
Drew	Audited	Approved	Stamp, please! Thanks!
Date: 2023.09.11			

## Guangdong Dapu Telecom Technology Co.,Ltd

Building 5, No.24, Industrial East Road, Songshanhu Park, Dongguan, Guangdong, P.R. China

TEL: 0086-0769-88010888 FAX: 0086-0769-81800098



### Table of amendment

Version	Revision contents	Prepared by	Revised date
1.0	The first issued	<i>Amway</i>	2020.10.15
1.1	The “Mechanical Structure” changed	<i>Amway</i>	2020.12.01
1.2	The “ESD Level” “Mechanical Structure” “Reflow Soldering Curve” “Package: Tape & Reel” changed	<i>Amway</i>	2023.02.16
1.3	The “Mechanical Structure” “Phase Noise” changed	<i>Amway</i>	2023.04.11
1.4	The “Mechanical Structure” changed	<i>Amway</i>	2023.09.11



## 1. Electrical Parameters

MODEL: T53-0802-20.00MHz							
Item	Description	Parameters			Unit	Test Condition	
		Min.	Typ.	Max.			
Output	Frequency	20.00			MHz		
	Output Waveform	Clipped Sine Wave					
	Vp-p	0.8			V		
	Harmonics Level			-13		dBc	3 <sup>rd</sup>
				-20		dBc	5 <sup>th</sup>
	Start-up time			15	ms	90% amplitude	
Load	10KΩ//10pF						
Frequency Stabilities	Frequency Tolerance vs. Operating Temperature Range	-0.5		+0.5	$\times 10^{-6}$	T <sub>A</sub> varied from -40°C to 85°C, measurement referenced to frequency observed with T <sub>A</sub> =25°C, V <sub>cc</sub> =3.3V, O <sub>load</sub> =10KΩ//10pF, temperature variable speed less than 2°C per minute.	
	Nominal Frequency Tolerance	-1		+1	$\times 10^{-6}$	Measurement referenced to frequency observed with T <sub>A</sub> =25°C, V <sub>cc</sub> =3.3V within 30 days after ex-works.	
	Frequency Tolerance vs. Supply Voltage		±0.025		$\times 10^{-6}$	measurement referenced to frequency observed T <sub>A</sub> =25°C, V <sub>cc</sub> varied from 3.13V to 3.47V and O <sub>Load</sub> =10KΩ//10pF.	
	Frequency Tolerance vs. Load		±0.05		$\times 10^{-6}$	10% load change measurement referenced to frequency observed with T <sub>A</sub> =25°C, V <sub>cc</sub> =3.3V, and O <sub>Load</sub> =10KΩ//10pF.	
	Aging Tolerance 1 Year	-1		+1	$\times 10^{-6}$	T <sub>A</sub> =25 °C, V <sub>cc</sub> =3.3V and after 1h of operation.	
	Aging Tolerance 10 Year	-5		+5	$\times 10^{-6}$		
	Acceleration Sensitivity		2		$\times 10^{-9}/g$	Gamma vector,3-axes,30-1500Hz.	
	Solpe over temperature	-0.1		+0.1	$\times 10^{-6}/^{\circ}\text{C}$	ΔF/ΔT	
	Reflow Shift	-1		+1	$\times 10^{-6}$	Pre to post reflow ΔF(measured ≥ 60 minutes after reflow)	
Power Supply	Operating Current			4	mA	@25°C, V <sub>cc</sub> =3.3V, O <sub>Load</sub> =10KΩ//10pF.	
	Supply Voltage	3.13	3.3	3.47	V		



Phase Noise	Phase Noise @25°C		-68		dBc/Hz	1Hz
			-95			10Hz
			-122			100Hz
			-142			1KHz
			-152			10KHz
			-155			100KHz
			-155			1MHz
Environmental Conditions	Operable Temperature	-40		+85	°C	
	Storage Temperature	-55		+105	°C	
	ESD Level	Human Body Model,class2: 2000V to 4000V; ANSI/ESDA/JEDEC JS-001-2010.				
		Machine Model, class B: 200V to 400V; JEDEC JESD22-A115C.				
	Moisture Sensitivity Level	Level 2.				
	Vibration	Test Condition: 0.75mm ;acceleration:10g;10Hz~2000Hz, one cycle per 30 min, test 2 hour. (3 times for each 3 directions X ,Y , Z) .IEC 68-2-06 Test Fc.				
Shock	100g; 6ms; half sine wave (3 times for each 3 directions X ,Y, Z ),IEC 68-2-27 Test Ea/Severity 50A.					
Full Package Storage	Relative humidity (%)	20% ~70%				
	Temperature (°C)	-10~35°C				



## 2. Mechanical Structure(mm)

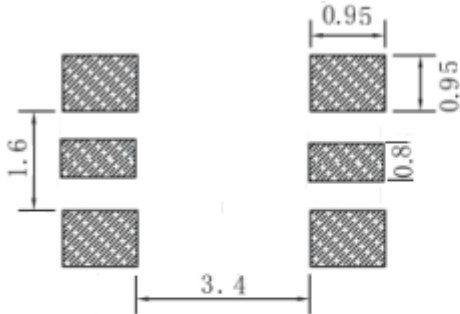

Solder pad layout

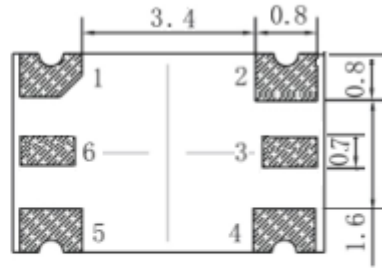

Bottom view



Right view



Side view

### PIN FUNCTION

PIN	NOTATION	FUNCTION
1	NC	Not Connect
2	GND	GND
3	NC	Not Connect
4	OUTPUT	RF Output
5	VCC	Supply Voltage
6	NC	Not Connect

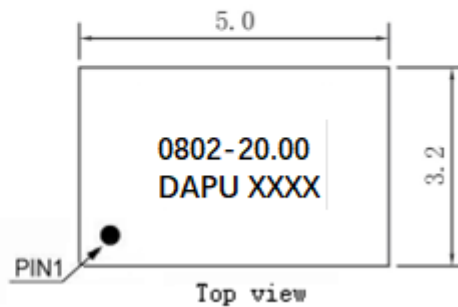

Top view

**Note1:** Tolerance  $\pm 0.2\text{mm}$  without mark

**Note2:** Referential weight 0.05g

**Note3:** The first two xx representative: week

After two xx representative: year



### 3. Test Circuit

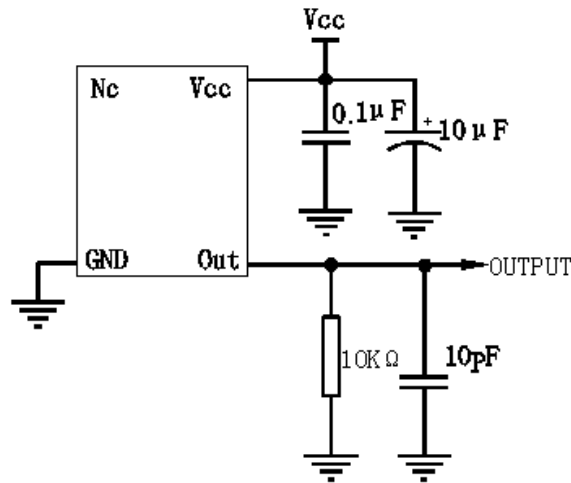

### 4. Reflow Soldering Curve (RoHS)

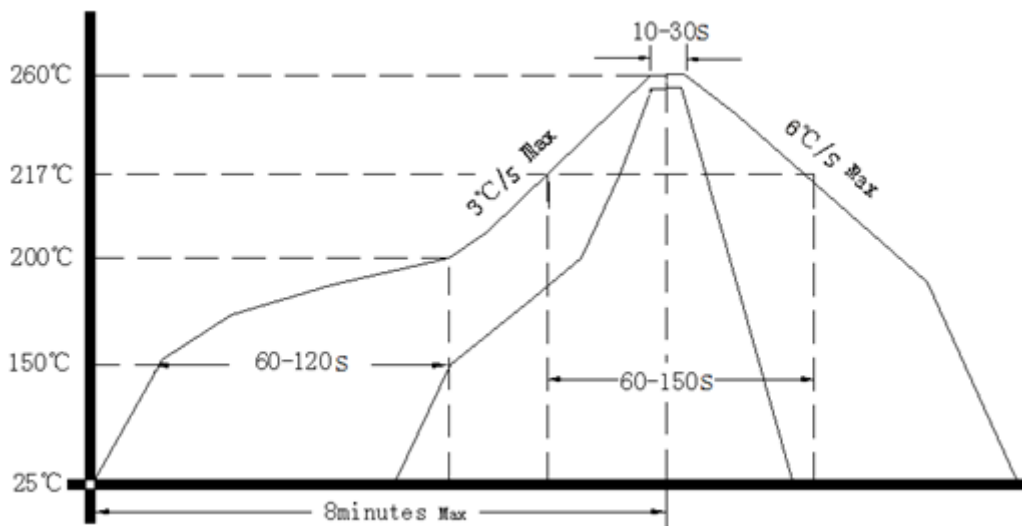

### 5. Package: Tape & Reel (mm)

