

Travelling Merchant: _____

DATASHEET

Standard: **O79A-K319-20.00MHz-S664**

P/N: _____

Plot			The Label
Drew	Audited	Approved	Stamp, please! Thanks!
Date: 2024.05.13			

Guangdong Dapu Telecom Technology Co.,Ltd

Building 5, No.24, Industrial East Road, Songshanhu Park, Dongguan, Guangdong, P.R. China

TEL: 0086-0769-88010888 FAX: 0086-0769-81800098



Table of amendment

Version	Revision contents	Prepared by	Revised date
1.0	The first issued	<i>Amway</i>	2024.05.13



1. Electrical Parameters

MODEL: O79A-K319-20.00MHz-S664						
Item	Description	Parameters			Unit	Test Condition
		Min.	Typ.	Max.		
Output	Frequency	20.00			MHz	
	Output Waveform	HCMOS				
	Output Low Voltage			0.4	V	$V_{cc}=3.3V, O_{load}=15\text{ pF}$
	Output High Voltage	2.4			V	$V_{cc}=3.3V, O_{load}=15\text{ pF}$
	Duty Cycle	45		55	%	@50%
	Rise / Fall Time			6	ns	10%~90%
	Startup time till valid waveform			50	ms	Time until RF output waveform is within output level, duty cycle and rise/fall time spec
	Load	15			pF	
Frequency Stabilities	Frequency Tolerance vs. Operating Temperature Range	-0.01		+0.01	$\times 10^{-6}$	T_A varied from -40°C to 95°C , measurement referenced to frequency observed with $f_{ref}=(f_{max}+f_{min})/2, V_{cc}=3.3V, O_{load}=15\text{ pF}$, temperature variable speed less than 2°C per minute.
	Initial Frequency Tolerance	-1		+1	$\times 10^{-6}$	Measurement referenced to frequency observed with $T_A=25^{\circ}\text{C}, V_{cc}=3.3V$ within 30 days after ex-works.
	Frequency Tolerance vs. Supply Voltage	-5		+5	$\times 10^{-9}$	measurement referenced to frequency observed $T_A= -40\sim 95^{\circ}\text{C}, V_{cc}$ varied from 3.135V to 3.465V, and $O_{Load}=15\text{ pF}$.
	Frequency Tolerance vs. Load	-5		+5	$\times 10^{-9}$	5% load change measurement referenced to frequency observed with $T_A=25^{\circ}\text{C}, V_{cc}=3.3V, O_{Load}=15\text{ pF}$.
	Frequency vs. Temperature Slope	-0.5		+0.5	$\times 10^{-9}/^{\circ}\text{C}$	T_{amb} slope $\pm 1^{\circ}\text{C}/\text{min}$ with any temperature window over operating temperature range. Includes also hysteresis effects. Slope measurement for device qualification as described in the related note.
	Aging Tolerance Per Day	-2		+2	$\times 10^{-9}$	$T_A=25^{\circ}\text{C}, V_{cc}=3.3V$, and after 30 days of operation.
	Aging Tolerance 1 Year	-0.5		+0.5	$\times 10^{-6}$	



	Warm up Time			3	minutes	Time until RF output is within $\pm 0.1\text{ppm}$ referenced to last frequency reading 1 h after startup, $T_A=25^\circ\text{C}$.	
	Steady Consumption			230	mA	@25°C	
	Warm up current			600	mA		
	Supply Voltage	3.135	3.3	3.465	V		
Phase Noise	Phase Noise -40~95°C		-75	-65	dBc/Hz	1Hz	
			-113	-108		10Hz	
			-146	-138		100Hz	
			-160	-154		1KHz	
			-163	-158		10KHz	
			-163	-158		100KHz	
			-163	-158		1MHz	
Environmental Conditions	Operating Temperature	-40		+95	°C		
	Operable Temperature	-45		+105	°C		
	Storage Temperature	-55		+105	°C		
	Relative Humidity Range	5		95	%		
	Absolute Humidity Range	1		29	g/m ³		
	Air Pressure Range	70		106	kPa		
	ESD Level	Human Body Model,class2: 2000V to 4000V; ANSI/ESDA/JEDEC JS-001-2010.					
		Machine Model, class B: 200V to 400V; JEDEC JESD22-A115C.					
	Moisture Sensitivity Level	Level 3.					
	Vibration	Test Condition: 0.75mm ;acceleration:10g;10Hz~2000Hz, one cycle per 30 min, test 2 hour. (3 times for each 3 directions X ,Y , Z) .IEC 68-2-06 Test Fc.					
Shock	100g; 6ms; half sine wave (3 times for each 3 directions X ,Y, Z),IEC 68-2-27 Test Ea/Severity 50A.						



2. Mechanical Structure(mm)

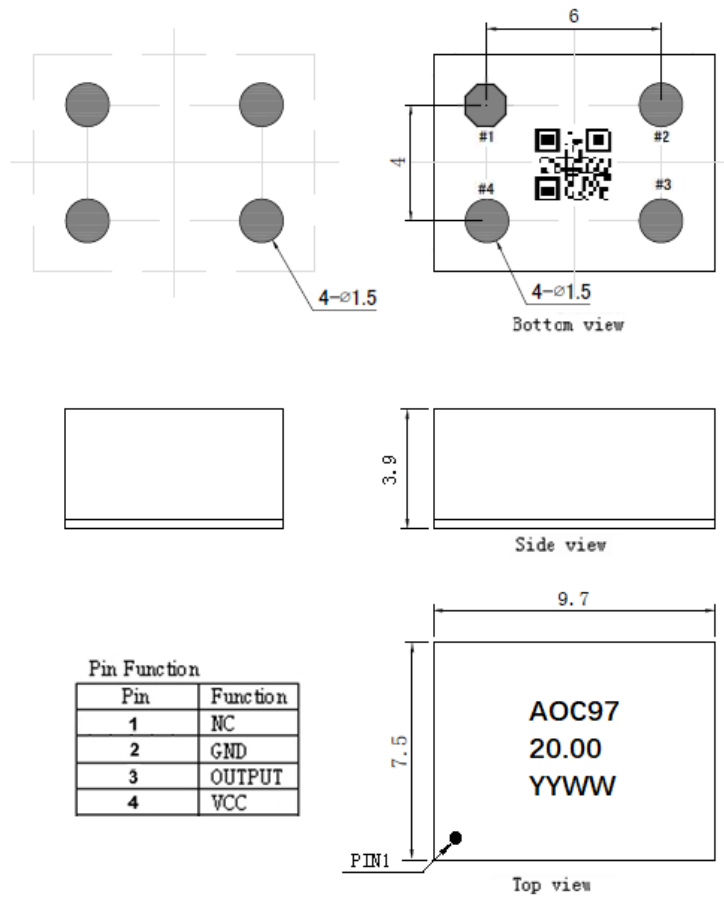

Note1: Tolerance $\pm 0.3\text{mm}$ without mark

Note2: The first two YY representative: year
After two WW representative: week

Note3: Referential Weight 0.4g

Note4: NC is not connect

3. Test circuit

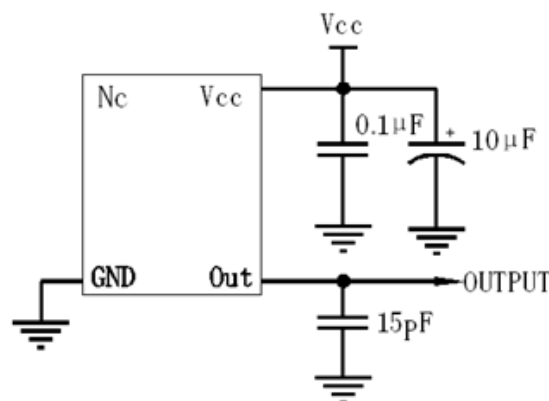



4. Reflow Soldering Curve (RoHS)

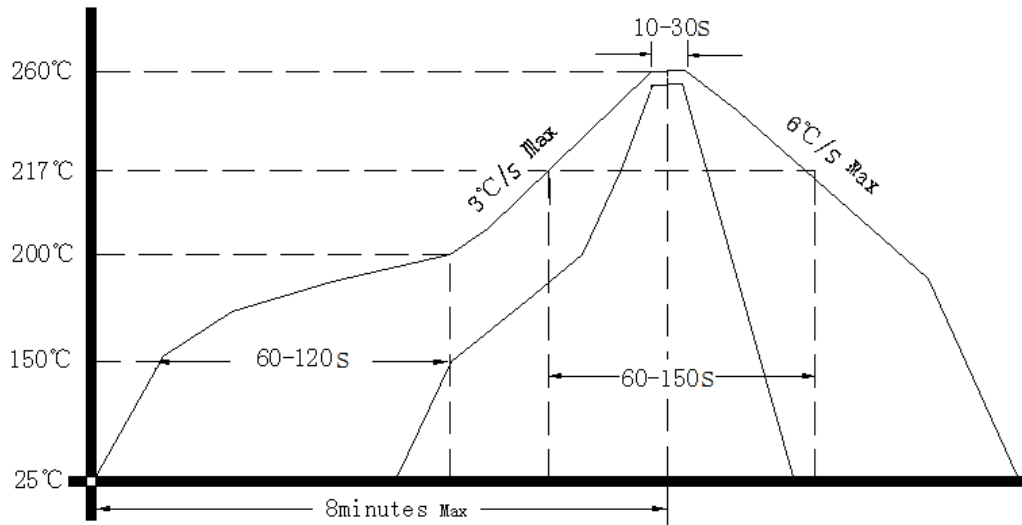

Note: Passing through reflow upside down is not supported

5. Package: Tape & Reel (mm)

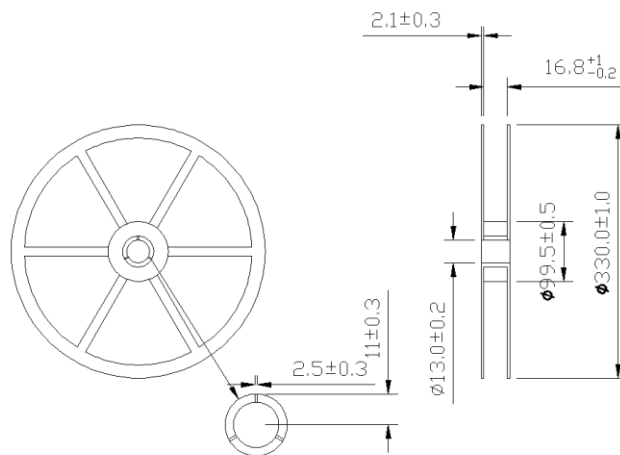
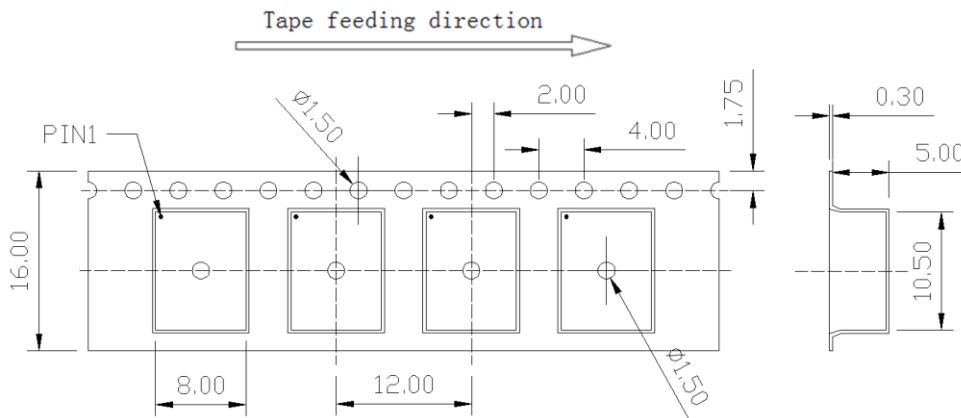

1000PCS/Rel