

Customer Code : \_\_\_\_\_

# DATASHEET

DAPU P/N: **O11L-A312-8.192MHz-A**

Customer P/N: \_\_\_\_\_

DAPU			Customer Approval
Drew	Audited	Approved	Stamp, please! Thanks!
Date: 2024.05.31			

## Guangdong Dapu Telecom Technology Co.,Ltd

Building 5, No.24, Industrial East Road, Songshanhu Park, Dongguan, Guangdong, P.R. China

TEL: 0086-0769-88010888 FAX: 0086-0769-81800098





## 1. Electrical Parameters

MODEL:O11L-A312-8.192MHZ-A						
Item	Description	Parameters			Unit	Test Condition
		Min.	Typ.	Max.		
Output	Frequency	8.192			MHz	
	Output Waveform	HCMOS				
	Output Low Voltage			0.4	V	$V_{cc}=3.3V, O_{load}=15pF$
	Output High Voltage	2.8			V	$V_{cc}=3.3V, O_{load}=15pF$
	Duty Cycle	45	50	55	%	@50%
	Rise / Fall Time (10%~90%)			10	ns	
	Load	15			pF	
Frequency Stabilities	Frequency Tolerance vs. Operating Temperature Range	-0.5		+0.5	$\times 10^{-9}$	$T_A$ varied from $-10^{\circ}C$ to $50^{\circ}C$ , measurement referenced to frequency observed with $f_{ref}=(f_{max}+f_{min})/2, V_{cc}=3.3V, O_{load}=15pF$ , temperature variable speed less than $2^{\circ}C$ per minute.
	Initial Frequency Tolerance	-0.2		+0.2	$\times 10^{-6}$	Measurement referenced to frequency observed with $T_A=25^{\circ}C, V_{cc}=3.3V, V_c=1.4V$ , and after 15 minutes of operation, within 30 days after ex-works.
	Frequency Tolerance vs. Supply Voltage	-2		+2	$\times 10^{-9}$	measurement referenced to frequency observed $T_A=25^{\circ}C, V_{cc}$ varied from 3.13V to 3.47V, and $O_{Load}=15pF$ .
	Frequency Tolerance vs. Load	-2		+2	$\times 10^{-9}$	5% load change measurement referenced to frequency observed with $T_A=25^{\circ}C, V_{cc}=3.3V, V_c=1.4V$ , and $O_{Load}=15pF$ .
	Short-Term Stability: Allan Variance		1		$\times 10^{-11}$	Temperature stability, no EMI\EMC or other interference, test after power for 1hour ref. to $25^{\circ}C$ ; 1s.
	Aging Tolerance Per Day	-1		+1	$\times 10^{-9}$	$V_{cc}, T_A$ constant measurement referenced to frequency observed with $T_A=25^{\circ}C, V_{cc}=3.3V$ , and after 30 days of operation.
	Aging Tolerance 1 Year	-0.1		+0.1	$\times 10^{-6}$	
Power Supply	Supply Voltage	3.13	3.3	3.47	V	
	Reference Voltage	2.85		3.05	V	
	Steady Consumption			60	mA	@ $25^{\circ}C$
	Warm up current			136	mA	
	Warm-Up Time			60	s	@ $25^{\circ}C$ within $\pm 0.1 \times 10^{-6}$ of final frequency with reference after 30 minutes on.



Voltage Control Characteristics	Frequency Tuning Range			-0.4	$\times 10^{-6}$	$V_c=0V$ . measurement referenced to $V_c=1.4V$
		-0.2		+0.2	$\times 10^{-6}$	$V_c=1.4V$ . measurement referenced to exactly 8.192MHz
		+0.4			$\times 10^{-6}$	$V_c=2.8V$ . measurement referenced to $V_c=1.4V$
	Linearity			10	%	
	Slope	Positive				
	Input Impedance	100				K $\Omega$
Phase Noise	Phase Noise		-105	-100	dBc/Hz	10Hz
			-137	-132		100Hz
			-148	-143		1KHz
			-152	-147		10KHz
			-154	-149		100KHz
Environmental Conditions	Operable Temperature	-10		+50	$^{\circ}C$	
	Storage Temperature	-55		+105	$^{\circ}C$	
	ESD Level	Human Body Model, class2: 2000V to 4000V; ANSI/ESDA/JEDEC JS-001-2010.				
		Machine Model, class B: 200V to 400V; JEDEC JESD22-A115C.				
	Moisture Sensitivity Level	Not humidity sensitive.				
	Vibration	Test Condition: 0.75mm ;acceleration:10g;10Hz~500Hz, one cycle per 30 min, test 2 hour. (3 times for each 3 directions X ,Y , Z), IEC 68-2-06 Test Fc.				
Shock	50g; 11ms; half sine wave (3 times for each 3 directions X, Y, Z), IEC 68-2-27 Test Ea/Severity 50A.					
Full Package Storage	Relative humidity (%)	20% ~70%				
	Temperature ( $^{\circ}C$ )	-10~35 $^{\circ}C$				



## 2. Mechanical Structure (mm)

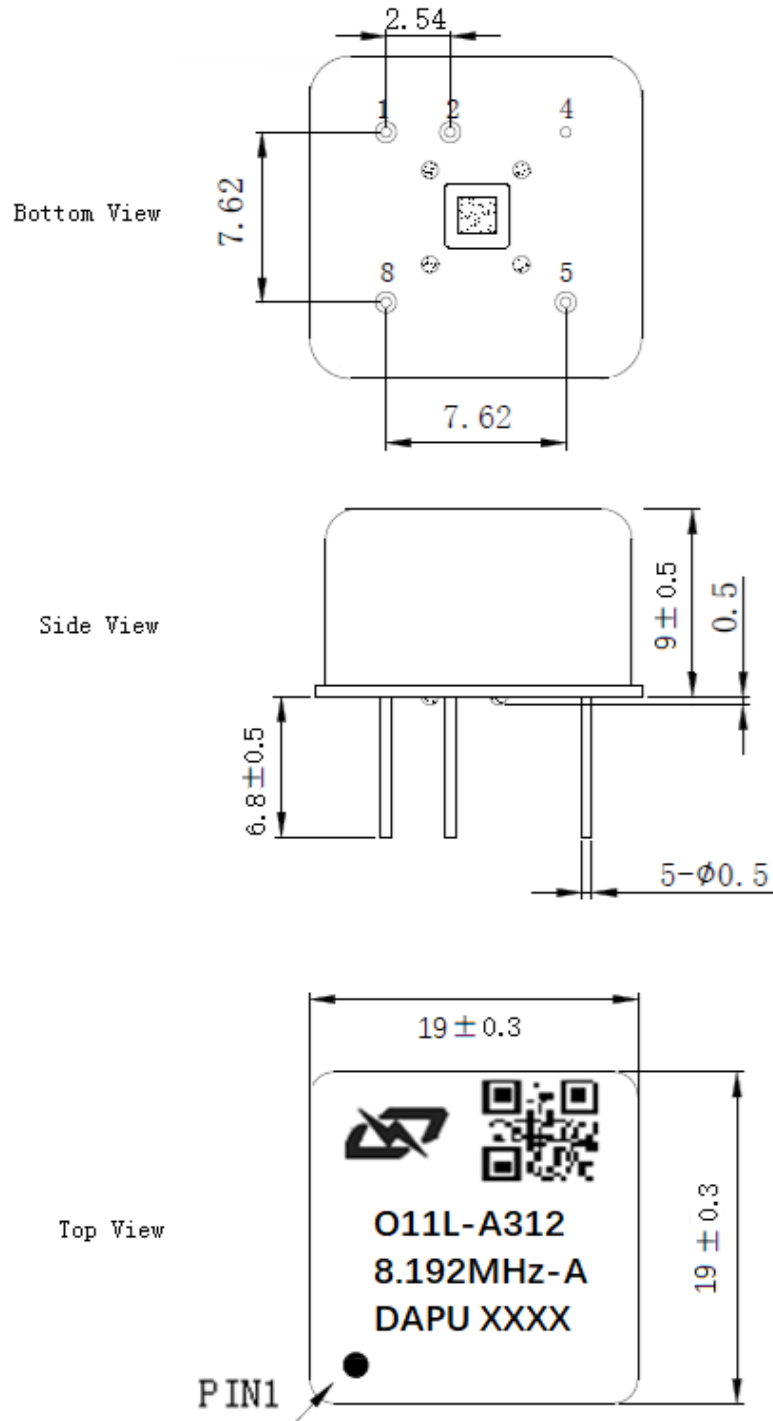

### PIN FUNCTION

PIN	FUNCTION
1	VC
2	Vref
4	GND
5	OUTPUT
8	VCC

- Note1:** Tolerance ± 0.20mm without mark
- Note2:** The first two XX representative: year  
After two XX representative: week
- Note3:** Referential weight 5.0g



### 3. Test Circuit

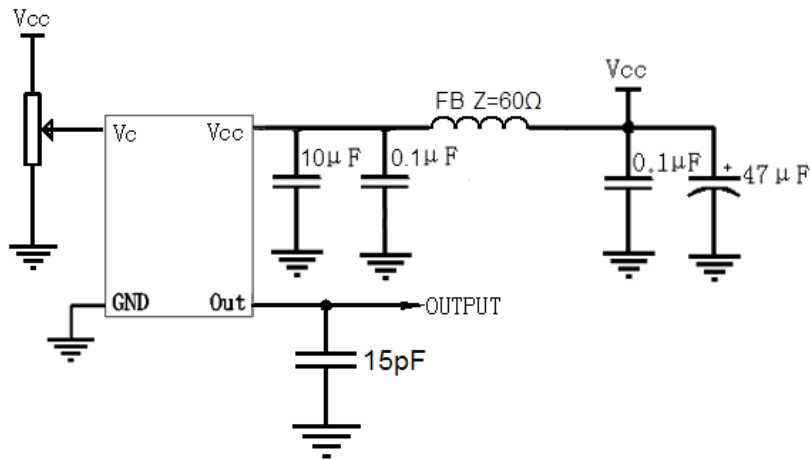

### 4. Reflow Soldering Curve (RoHS)

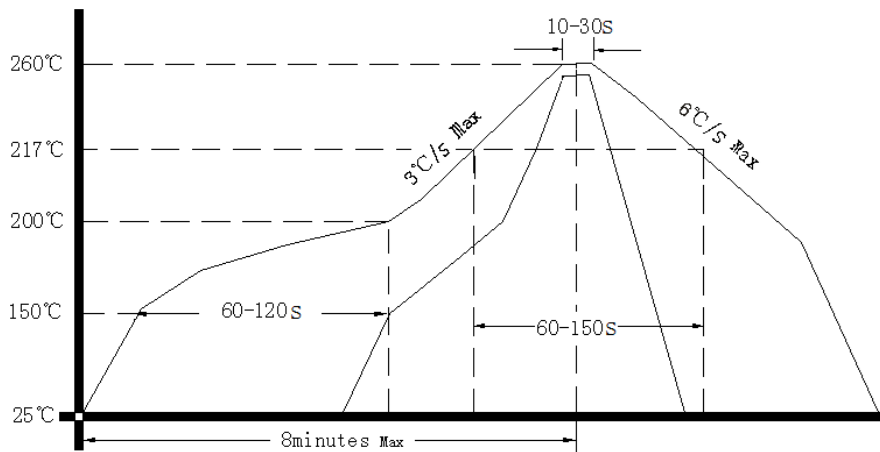

### 5. Package: Tape & Reel (mm)

