

Customer Code : \_\_\_\_\_

# DATASHEET

DAPU P/N :           **T936-T312-100.00MHz**          

P/N : \_\_\_\_\_

DAPU			Customer Approval
Drew	Audited	Approved	Stamp, please! Thanks!
Date: 2024.05.06			

## Guangdong Dapu Telecom Technology Co.,Ltd

Building 5, No.24, Industrial East Road, Songshanhu Park, Dongguan, Guangdong, P.R. China

TEL: 0086-0769-88010888 FAX: 0086-0769-81800098





## 1. Electrical Parameters

MODEL: T936-T312-100.00MHZ						
Item	Description	Parameters			Unit	Test Condition
		Min.	Typ.	Max.		
Output	Frequency	100.00			MHz	
	Output Waveform	HCMOS				
	Output Low Voltage			0.4	V	$V_{cc}=3.3V, O_{load}=15\text{ pF}$
	Output High Voltage	2.7			V	$V_{cc}=3.3V, O_{load}=15\text{ pF}$
	Duty Cycle	45	50	55	%	@50%
	Rise / Fall Time (10%~90%)			5	ns	@25°C
	Load	15			pF	
Frequency Stabilities	Frequency Tolerance vs. Operating Temperature Range	-0.5		+0.5	$\times 10^{-6}$	$T_A$ varied from -45°C to 75°C, measurement referenced to frequency observed with $f_{ref} = (f_{max} + f_{min}) / 2$ , $V_{cc}=3.3V, V_c=1.5V, O_{load}=15\text{ pF}$ , temperature variable speed less than 2°C per minute.
	Initial Frequency Tolerance	-1.0		+1.0	$\times 10^{-6}$	Measurement referenced to frequency observed with $T_A=25^\circ\text{C}, V_{cc}=3.3V, V_c=1.5V$ , and after 15 minutes of operation, within 30 days after ex-works.
	Frequency Tolerance vs. Supply Voltage	-0.1		+0.1	$\times 10^{-6}$	measurement referenced to frequency observed $T_A=25^\circ\text{C}, V_{cc}$ varied from 3.13V to 3.47V, $V_c=1.5V$ , and $O_{Load}=15\text{ pF}$ .
	Frequency Tolerance vs. Load	-0.1		+0.1	$\times 10^{-6}$	5% load change measurement referenced to frequency observed with $T_A=25^\circ\text{C}, V_{cc}=3.3V, V_c=1.5V, O_{Load}=15\text{ pF}$ .
	Aging Tolerance Per Day	-10		+10	$\times 10^{-9}$	TA=25°C, $V_{cc}=3.3V, V_c=1.5V$ and after 1h of operation.
	Aging Tolerance 1 Year	-1		+1	$\times 10^{-6}$	
	Aging Tolerance 10 Year	-4.6		+4.6	$\times 10^{-6}$	
Power Supply	Current Consumption			30	mA	@25°C, $V_{cc}=3.3V, O_{Load}=15\text{ pF}$ .
	Supply Voltage	3.13	3.3	3.47	V	@25°C



Voltage Control Characteristics	Frequency Tuning Range	-15		-9	$\times 10^{-6}$	$V_c=0.5V$ . measurement referenced to $V_c=1.5V$
		-1		+1	$\times 10^{-6}$	$V_c=1.5V$ . measurement referenced to exactly 100.00MHz
		+9		+15	$\times 10^{-6}$	$V_c=2.5V$ . measurement referenced to $V_c=1.5V$
	Linearity			10	%	
	Slope	Positive				
	Input Impedance	100				K $\Omega$
Phase Noise	Phase Noise		-100	-95	dBc/Hz	100Hz
			-130	-125		1KHz
			-150	-145		10KHz
			-160	-155		100KHz
			-160	-155		1MHz
			-160	-155		10MHz
Environmental Conditions	Operable Temperature	-45		+75	$^{\circ}C$	
	Storage Temperature	-55		+105	$^{\circ}C$	
	ESD Level	Human Body Model,class2: 2000V to 4000V; ANSI/ESDA/JEDEC JS-001-2010.				
		Machine Model, class B: 200V to 400V; JEDEC JESD22-A115C.				
	Moisture Sensitivity Level	Level 3.				
	Vibration	Test Condition: 0.75mm ;acceleration:10g;10Hz~2000Hz, one cycle per 30 min, test 2 hour. (3 times for each 3 directions X ,Y , Z ).IEC 68-2-06 Test Fc.				
Shock	100g; 6ms; half sine wave (3 times for each 3 directions X ,Y , Z ),IEC 68-2-27 Test Ea/Severity 50A.					



## 2. Mechanical Structure(mm)

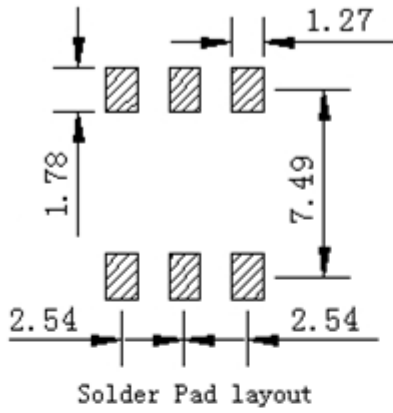

Bottom View

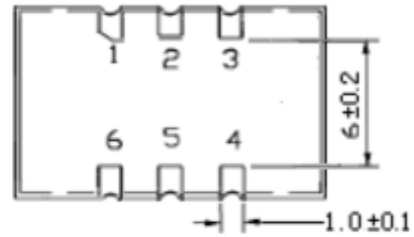

Right View

Side View

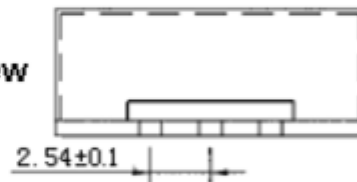

PIN FUNCTION

1	VC
2	NC
3	GND
4	OUTPUT
5	NC
6	VCC

Top View

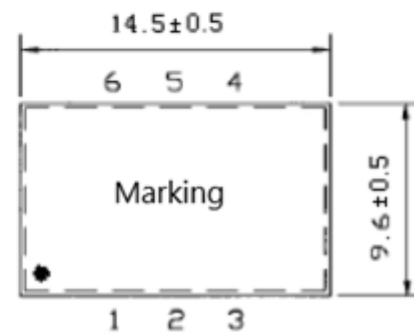

### Marking:

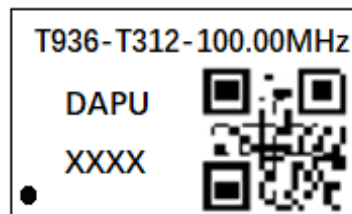

**Note1:** Tolerance  $\pm 0.2\text{mm}$  without mark

**Note2:** Referential weight 2.2g

**Note3:** NC is not connect

**Note4:** The first two xx representative: week After two xx representative: year



### 3. Test circuit

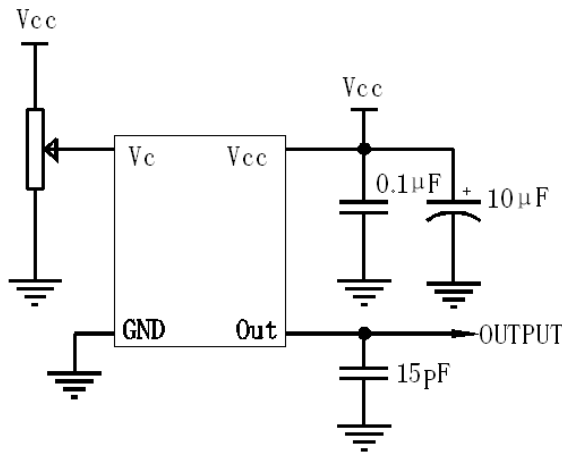

### 4. Reflow Soldering Curve (RoHS)

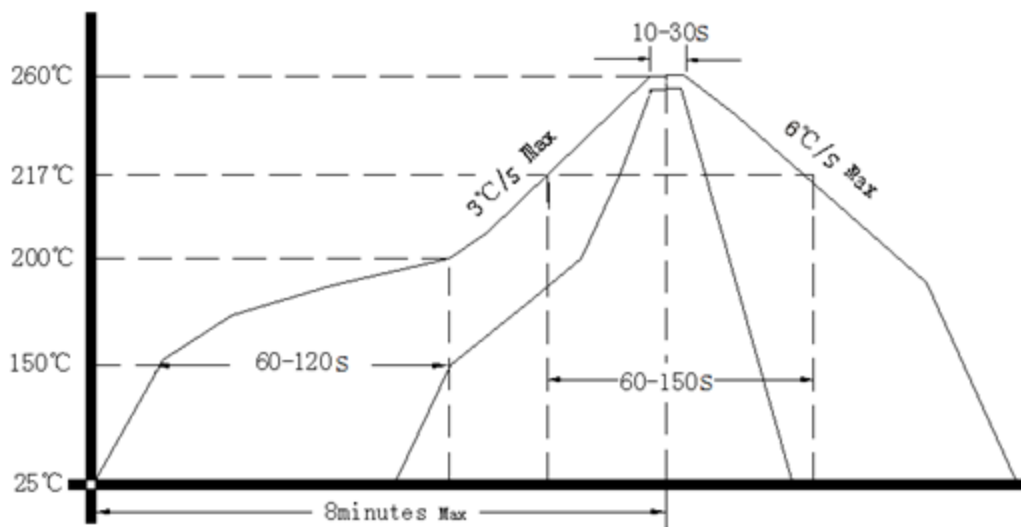

### 5. Package: Tape & Reel (mm)

