

**Customer Code:** \_\_\_\_\_

# DATASHEET

**DAPU P/N: DPZ2240M0000ABA0NB0**

<b>DAPU</b>			<b>Customer Approval</b>
Drew	Audited	Approved	Stamp, please! Thanks!
Jieshu ZHENG	Jianhua LIN	Gangtao FENG	
Date:	2024/3/12		

## Guangdong Dapu Telecom Technology Co.,Ltd

Bldg 5, SSL Modern Enterprise Accelerator Zone, Dongguan City, Guangdong Province, PRC China  
TEL: 0086-0769-88010888 FAX: 0086-0769-81800098



## 1、Electrical Parameter

MODEL:		DPZ2240M0000ABA0NB0					
For Automotive							
No.	Parameters	SYM.	Electrical Spec.				Notes
			Min.	Typ.	Max.	Units	
1	Nominal Frequency	FL	40.000			MHz	
2	Standard	-	AEC-Q200			-	
3	Oscillation Mode	-	Fundamental			-	
4	Frequency Tolerance	-	-20		20	ppm	At 25°C
5	Frequency Stability	-	-20		20	ppm	Over Operating Temperature Range (Reference 25 °C)
6	Operating Temperature	Topr	-40		105	°C	
7	Storage Temperature	Tstg	-55		125	°C	
8	Supply Voltage	V <sub>DD</sub>	2.97	3.30	3.63	V	
9	Input Current	I <sub>cc</sub>			10	mA	
10	Output waveform	-	CMOS				
11	Output Load	CL		15			
12	Output Voltage High	V <sub>OH</sub>	0.9			V <sub>DD</sub>	
13	Output Voltage Low	V <sub>OL</sub>			0.1	V <sub>DD</sub>	
14	Rise Time	Tr			5	ns	10% -90% V <sub>DD</sub> Level
15	Fall Time	Tf			5	ns	90% -10% V <sub>DD</sub> Level
16	Aging	-	-3		3	ppm	First Year at 25°C
17	Tri-State Output Enable	-	0.7			V <sub>DD</sub>	Pin 1, OE
18	Tri-State Output Disable	-			0.3	V <sub>DD</sub>	Pin 1, OE
19	Duty Cycle	-	45~55			%	
20	Start-Up Time	T <sub>start</sub>			2	ms	Measured from the time V <sub>DD</sub> reaches its rated minimum value

## 2、Mechanical Structure

### 2.1 Dimensions

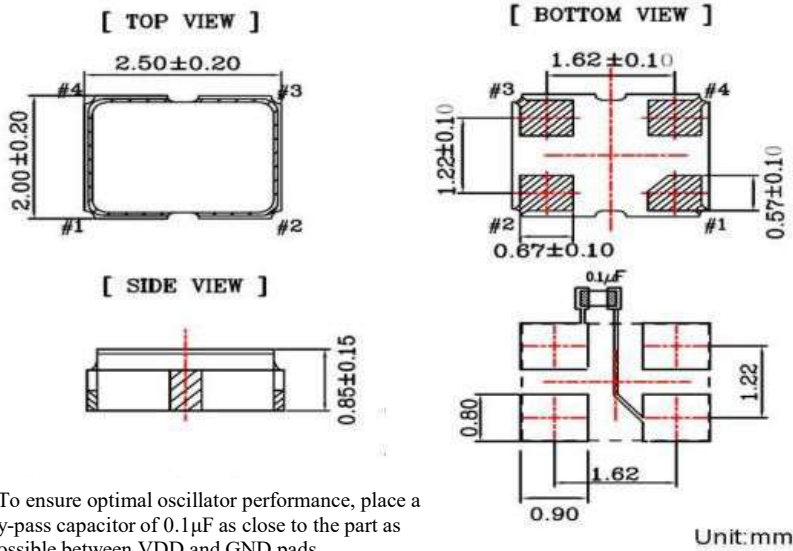

Pin	Function
#1	Tri-State
#2	GND
#3	Output
#4	VDD

### 2.2 Marking



- DAPU LOGO
- 40.000 ----- Frequency
- XXYY ----- Manufactured day: XX      YY  
Year      Week
- ----- Pin 1

### 3、 Test Circuit

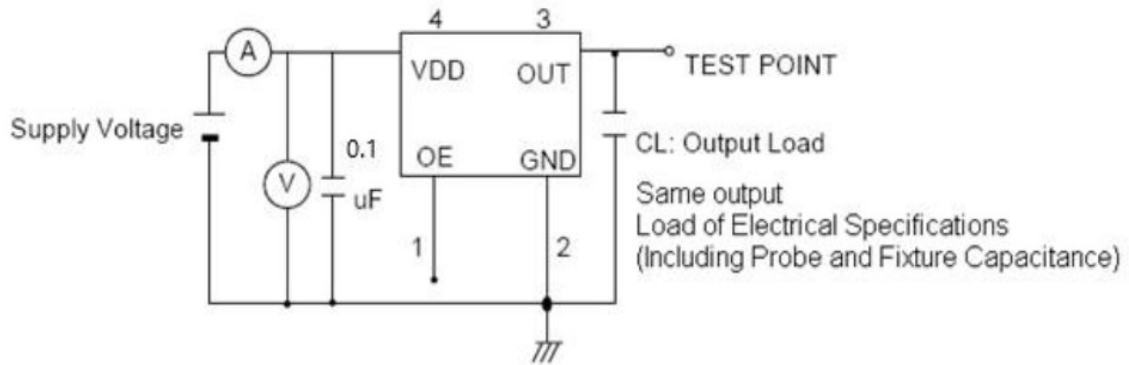

Control input (output enable/disable)

Tri-State Pin	Output Pin
Logic 1 or open	Oscillator output
Logic 0	Disable output to high impedance

### 4、 Reflow Soldering Curve (RoHS)

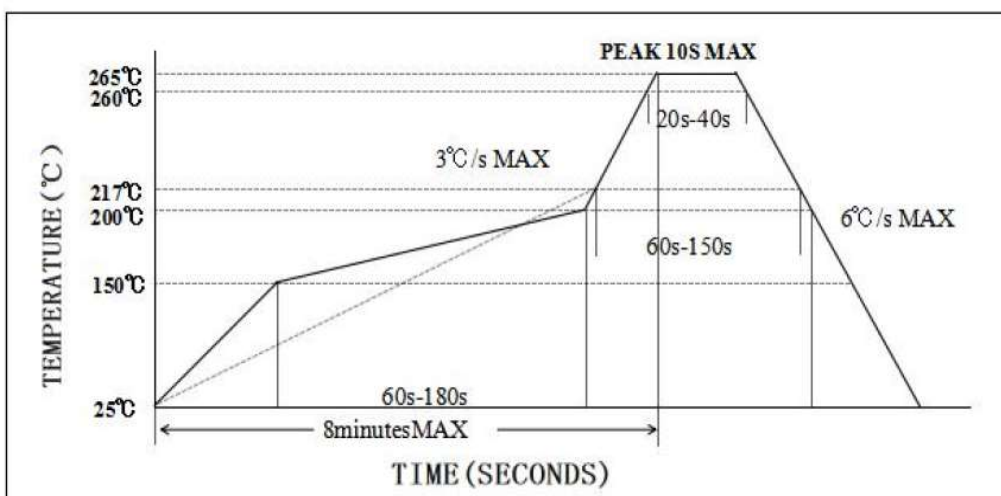

## 5、 Package: Tape & Reel (mm)

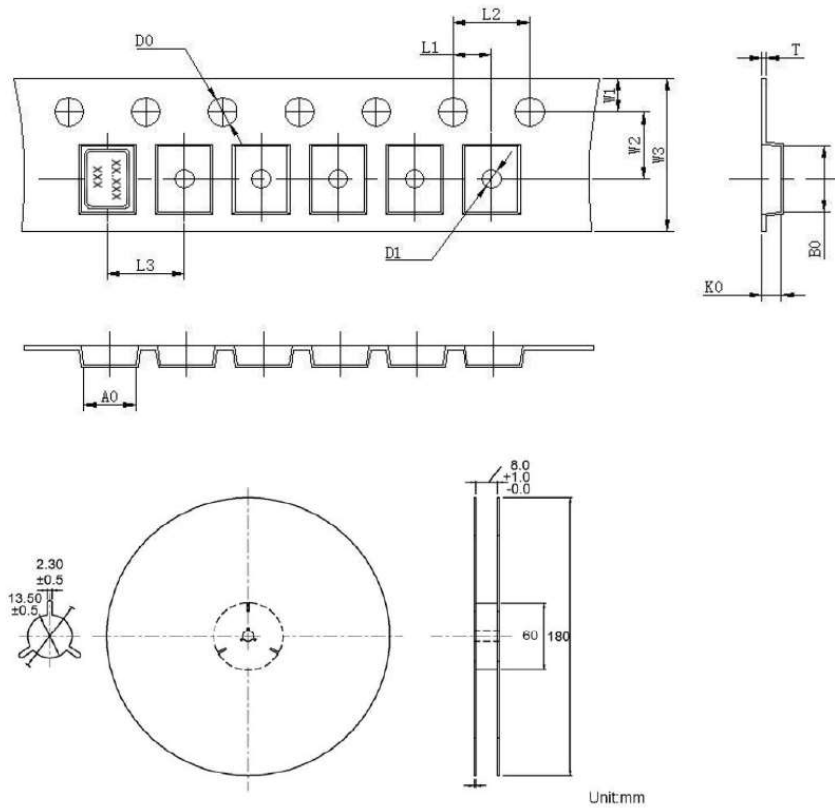

L1	2.00 ± 0.1
L2	4.00 ± 0.1
L3	4.00 ± 0.1
D0	1.55 ± 0.05
D1	1.20 ± 0.5
W1	1.75 ± 0.1
W2	3.50 ± 0.1
W3	8.00 ± 0.2
A0	2.25 ± 0.1
B0	2.7 ± 0.1
K0	1.45 ± 0.1
T	0.25 ± 0.05

## 6、 Reliability Test Specification

6.1 Reliability Test (Reference AEC-Q200)				
NO.	Test Items	Test Standard	Test Condition	Standard
1	High temperature storage	MIL-STD-202 Method 108	The crystal was placed at a temperature of 125±2°C for 1000 hours.	A
2	Temperature cycle	JESD22 Method JA-104	Crystal do 1000 cycles according to the table below temperature. 	A
3	Temperature and humidity	MIL-STD-202 Method 103	The crystal is placed for 1000 hours at a temperature of 85±2°C and a humidity of 85% Time.	A
4	Life span	MIL-STD-202 Method 108	The crystal is placed at a temperature of 105°C ± 2°C for 1000 hours (applied rated VDD).	A

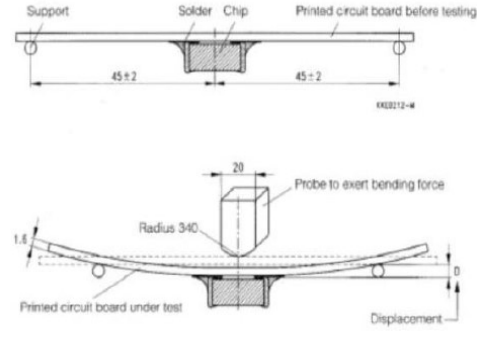
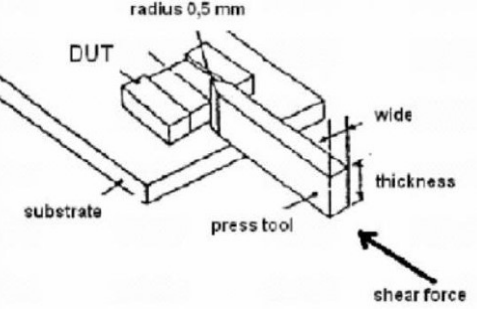
NO.	Test Items	Test Standard	Test Condition	Standard
5	Shock	MIL-STD-202 Method 213	Shock method: half sine wave 100G Duration: 6ms Direction: X, Y, Z Axia l, 6 faces, 18 shocks in total	A
6	Vibration	MIL-STD-202 Method 204	Vibration frequency: 10~2000Hz Vibration amplitude: 1.5mm Scan time: 20 min Directions: X, Y, Z (12 cycles in each of the three directions)	A
7	Resistance to soldering heat	MIL-STD-202 Method 210	Reflow soldering: Peak temperature:260±5°C time: 10s±1s.	A
8	Solderability	J-STD-002	Soldering temperature:245±5°C Immersion time:5±0.5 seconds Flux Rosin: Resin Methanol Solve nt ( 1 : 4 )	B
9	Panel bending	AEC-Q200-005	Apply pressure to the center of the product until it bends to a minimum of 2mm and keep 60±5 seconds. 	A
10	Terminal strength	AEC-Q200-006	Apply a force of 1.8Kg laterally for 60±1 seconds. 	A

## 6.2 Test Judgment

Specification	
A	Test after 24±2 hours under normal temperature and normal humidity, and meet electrical performance requirements.
B	At least 95% of the immersed end is covered with new welding material.