

Customer Code: _____

DATASHEET

DAPU P/N: 055F-A445-10.00MHz-C

Customer P/N: _____

DAPU			Customer Approval
Drew	Audited	Approved	Stamp, please! Thanks!
Date: 2023.09.19			

Guangdong Dapu Telecom Technology Co.,Ltd

Building 5, No.24, Industrial East Road, Songshanhu Park, Dongguan, Guangdong, P.R. China

TEL: 0086-0769-88010888 FAX: 0086-0769-81800098



1. Electrical Parameters

MODEL: O55F-A445-10.00MHZ-C						
Item	Description	Parameters			Unit	Test Condition
		Min.	Typ.	Max.		
Output	Frequency	10.00			MHz	
	Output Waveform	Sine wave				
	Level	7		12	dBm	
	Load	50			Ω	
	Harmonics Suppression			-45	dBc	
Frequency Stabilities	Frequency Tolerance vs. Operating Temperature Range	-1		+1	$\times 10^{-9}$	T_A varied from 0°C to 75°C, measurement referenced to frequency observed with $f_{ref}=(f_{max}+f_{min})/2$, $V_{cc}=12.0V$, $O_{load}=50\Omega$, temperature variable speed less than 2°C per minute.
	Initial Frequency Tolerance	-0.03		+0.03	$\times 10^{-6}$	Measurement referenced to frequency observed with $T_A=25^\circ C$, $V_{cc}=12V$, $V_c=2.5V$, and after 15 minutes of operation, within 30 days after ex-works.
	Frequency Tolerance vs. supply voltage	-0.5		+0.5	$\times 10^{-9}$	measurement referenced to frequency observed $T_A=25^\circ C$, V_{cc} varied from 11.4V to 12.6V, $V_c=2.5V$, $O_{load}=50\Omega$.
	Frequency Tolerance vs. Load	-0.5		+0.5	$\times 10^{-9}$	5% Load Change Measurement referenced to frequency observed with $T_A=25^\circ C$, $V_{cc}=12.0V$, $V_c=2.5V$, $O_{load}=50\Omega$.
	Short-Term Stability: Allan Variance			0.3	$\times 10^{-12}$	Temperature stability, no EMI\EMC or other interference, test after power for 1hour ref. to 25°C; 1s.
	Aging Tolerance Per Day	-0.5		+0.5	$\times 10^{-9}$	V_{cc}, V_c, T_A constant Measurement referenced to frequency observed with $T_A=25^\circ C$, $V_{cc}=12.0V$, $V_c=2.5V$, $O_{load}=50\Omega$ and after 30 days of operation.
	Aging Tolerance Per 30 Days	-5		+5	$\times 10^{-9}$	
	Aging Tolerance First Year	-0.03		+0.03	$\times 10^{-6}$	
	Aging Tolerance 15 Years	-0.5		+0.5	$\times 10^{-6}$	



Power Supply	Supply Voltage	10.5	12.0	12.6	V	
	Steady Consumption			150	mA	@25°C
	Warm up current			400	mA	
	Reference Voltage	4.925	5	5.075	V	
Voltage Control Characteristics	Frequency Tuning Range	-0.65		-0.4	$\times 10^{-6}$	$V_c=0V$. measurement referenced to $V_c=2.5V$
		-0.03		+0.03	$\times 10^{-6}$	$V_c=2.5V$. measurement referenced to exactly 10.00MHz
		+0.4		+0.65	$\times 10^{-6}$	$V_c=5.0V$. measurement referenced to $V_c=2.5V$
	Linearity			10	%	
	Slope	Positive				
	Input Impedance	10			K Ω	
Phase Noise	Phase Noise @25°C			-120	dBc/Hz	1Hz
				-143		10Hz
				-155		100Hz
				-160		1KHz
				-165		10KHz
Environmental Conditions	Operating Temperature	0		+75	°C	
	Operable Temperature	0		+80	°C	
	Storage Temperature	-55		+105	°C	
	ESD Level	Human Body Model, class2: 2000V to 4000V; ANSI/ESDA/JEDEC JS-001-2010.				
		Machine Model, class B: 200V to 400V; JEDEC JESD22-A115C.				
	Moisture Sensitivity Level	Not humidity sensitive.				
Vibration	Test Condition: 0.75mm ;acceleration:10g;10Hz~500Hz, one cycle per 30 min, test 2 hour. (3 times for each 3 directions X ,Y , Z), IEC 68-2-06 Test Fc.					
Shock	50g; 11ms; half sine wave (3 times for each 3 directions X ,Y , Z),IEC 68-2-27 Test Ea/Severity 50A.					
Full Package Storage	Relative humidity (%)	20%~70%				
	Temperature(°C)	-10~35°C				



2. Mechanical Structure (mm)

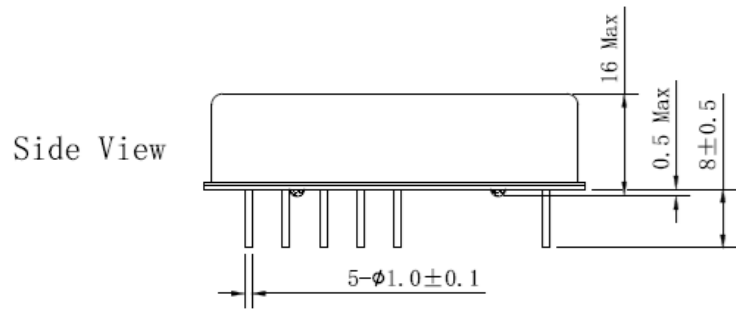
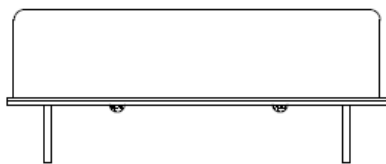
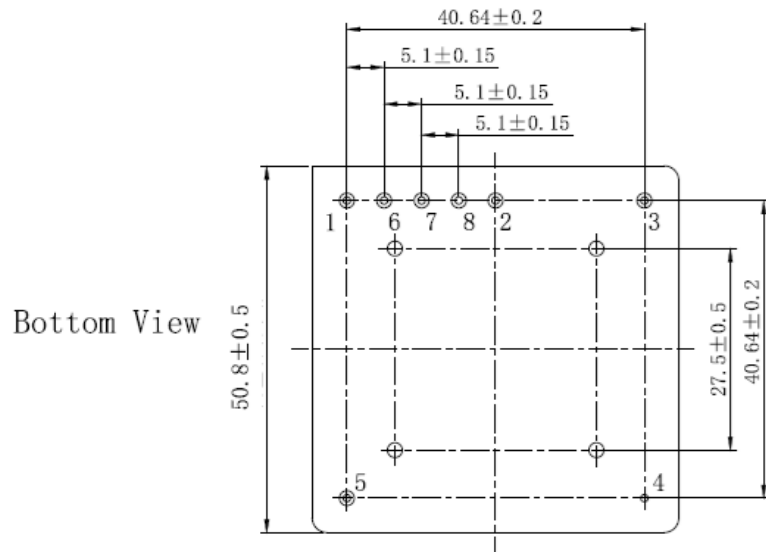

Pin	Designation
1	Voltage Control
2	Reference Voltage Output
3	RF Output
4	Ground
5	Supply Voltage
6	No Connected
7	No Connected
8	No Connected

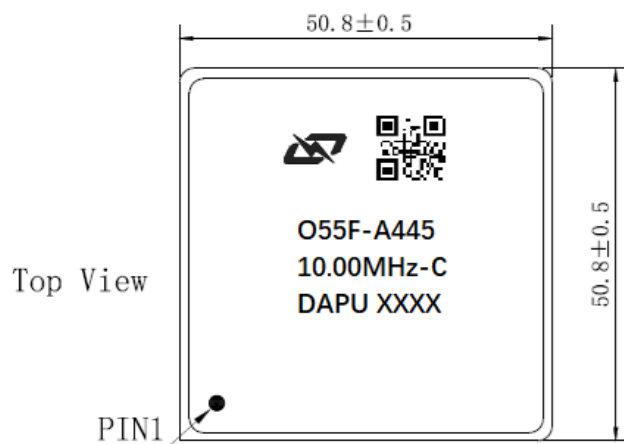

Note1: Tolerance ± 0.20 mm without mark.

Note2: The first two xx representative: week.

After two xx representative: year.



3. Test Circuit

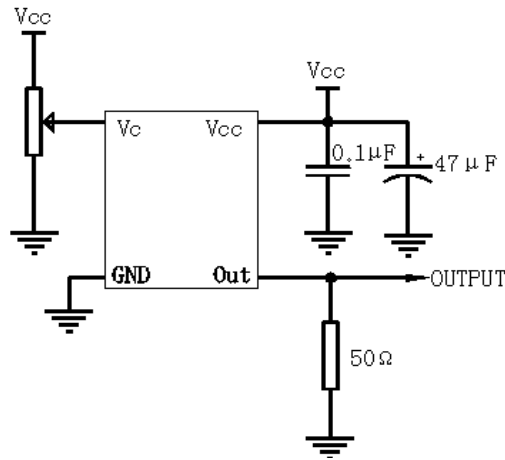

4. Reflow Soldering Curve (RoHS)

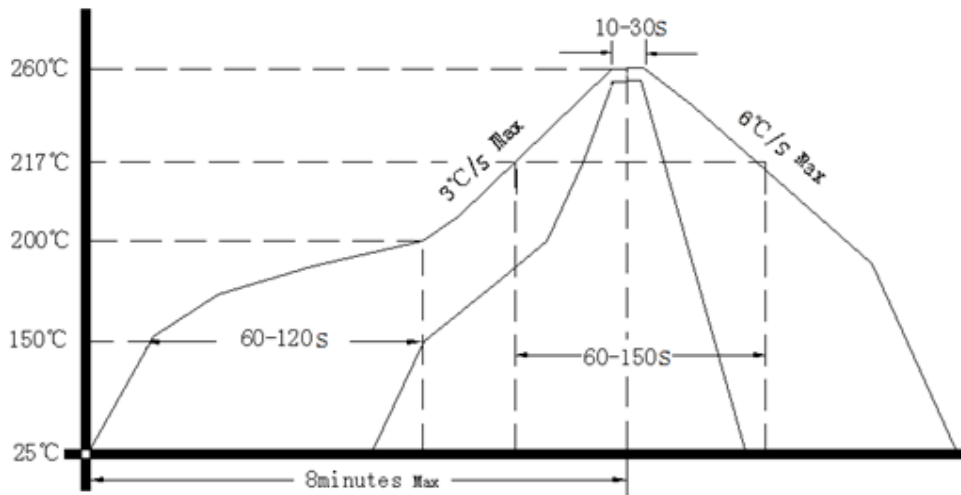

5. Package: Tape & Reel (mm)

