

Travelling Merchant: _____

DATASHEET

Standard: **T53-Y319-40.00MHz**

P/N: _____

Plot			The Label
Drew	Audited	Approved	Stamp, please! Thanks!
Date: 2023.08.11			

Guangdong Dapu Telecom Technology Co.,Ltd

Building 5, No.24, Industrial East Road, Songshanhu Park, Dongguan, Guangdong, P.R. China

TEL: 0086-0769-88010888 FAX: 0086-0769-81800098



Table of amendment

Version	Revision contents	Prepared by	Revised date
1.0	The first issued	<i>Amway</i>	2023.06.26
1.1	The “Mechanical Structure” changed	<i>Amway</i>	2023.08.11

DAPU

Confidential



1. Electrical Parameters

MODEL: T53-Y319-40.00MHz							
Item	Description	Parameters			Unit	Test Condition	
		Min.	Typ.	Max.			
Output	Frequency	40.00			MHz		
	Output Waveform	HCMOS					
	Output Low Voltage			0.4	V	$V_{cc}=3.3V, O_{load}=15\text{ pF}$	
	Output High Voltage	2.97			V	$V_{cc}=3.3V, O_{load}=15\text{ pF}$	
	Duty Cycle	45	50	55	%	@50%	
	Start up Time			3	ms	Stabilization time to +/-0.5ppm of final frequency.	
	Rise / Fall Time (10%~90%)			8	ns	@25°C	
	Load	15			pF		
Frequency Stabilities	Overall Stability	-4.6		+4.6	$\times 10^{-6}$	Including frequency stability vs.temperature tolerance ex factory, aging over 20 years, supply&load variation.	
	Frequency Tolerance vs. Operating Temperature Range	-0.28		+0.28	$\times 10^{-6}$	T_A varied from -40°C to 85°C, measurement referenced to frequency observed with $f_{ref}=(f_{max}+f_{min})/2, V_{cc}=3.3V, O_{load}=15\text{ pF}$, temperature variable speed less than 2°C per minute.	
	Initial Frequency Tolerance	-1.0		+1.0	$\times 10^{-6}$	Measurement referenced to frequency observed with $T_A=25^\circ\text{C}, V_{cc}=3.3V$ within 30 days after ex-works.	
	Frequency Tolerance vs. Supply Voltage	-0.1		+0.1	$\times 10^{-6}$	measurement referenced to frequency observed $T_A=25^\circ\text{C}, V_{cc}$ varied from 3.13V to 3.47V and $O_{Load}=15\text{ pF}$.	
	Frequency Tolerance vs. Load	-0.1		+0.1	$\times 10^{-6}$	10% load change measurement referenced to frequency observed with $T_A=25^\circ\text{C}, V_{cc}=3.3V$ and $O_{Load}=15\text{ pF}$.	
	Holdover		-0.01		+0.01	$\times 10^{-6}$	After 10 days operation.
			-0.04		+0.04	$\times 10^{-6}$	After 48hours operation.
	Aging Tolerance First Year	-0.5		+0.5	$\times 10^{-6}$	$T_A=25^\circ\text{C}, V_{cc}=3.3V$ and after 24h of operation.	
Aging Tolerance 20 Years	-3		+3	$\times 10^{-6}$			



Power Supply	Operating Current			8	mA	@25°C, V _{cc} =3.3V, O _{Load} =15 pF .
	Supply Voltage	3.13	3.3	3.47	V	
Phase Noise	Phase Noise @25°C		-90		dBc/Hz	10Hz
			-115			100Hz
			-136			1KHz
			-145			10KHz
			-160			100KHz
			-160			1MHz
RMS Phase Jitter			225		fs	12kHz to 20MHz
Environmental Conditions	Operable Temperature	-40		+85	°C	
	Storage Temperature	-55		+105	°C	
	ESD Level	Human Body Model,class2: 2000V to 4000V; ANSI/ESDA/JEDEC JS-001-2010.				
		Machine Model, class B: 200V to 400V; JEDEC JESD22-A115C.				
	Moisture Sensitivity Level	Level 2.				
	Vibration	Test Condition: 0.75mm ;acceleration:10g;10Hz~2000Hz, one cycle per 30 min, test 2 hour. (3 times for each 3 directions X ,Y , Z) .IEC 68-2-06 Test Fc.				
Shock	100g; 6ms; half sine wave (3 times for each 3 directions X ,Y , Z),IEC 68-2-27 Test Ea/Severity 50A.					



2. Mechanical Structure(mm)

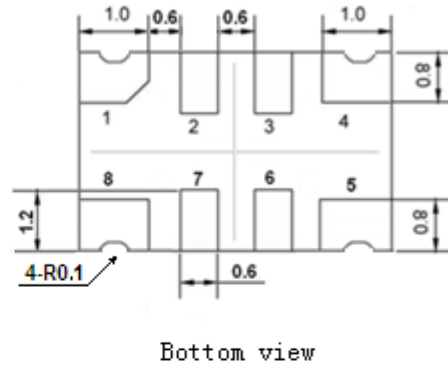
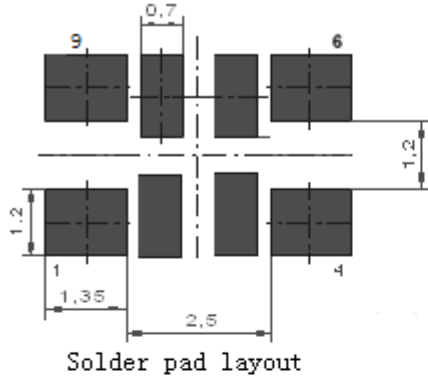

PIN FUNCTION

PIN	NOTATION	FUNCTION
1,2	NC	Not Connect
3	E/D	Enable/Disable
4	GND	GND
5	OUTPUT	RF Output
6,7	NC	Not Connect
8	VCC	Supply Voltage

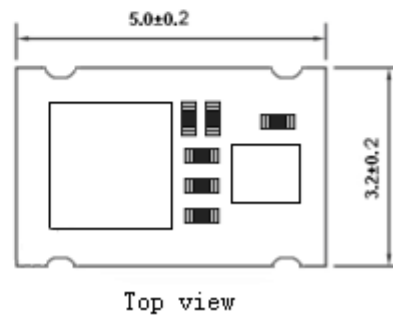
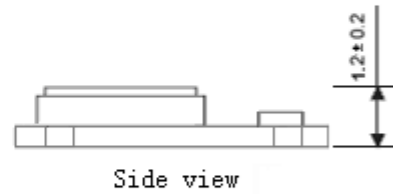

Note1: Tolerance ± 0.1 mm without mark

Note2: Referential Weight 0.05g

Note3: Pin 3 Function:

Enable/Disable	Open or Min.70% Vcc	Enable
Function	Max.30% Vcc	Disable



3. Test Circuit

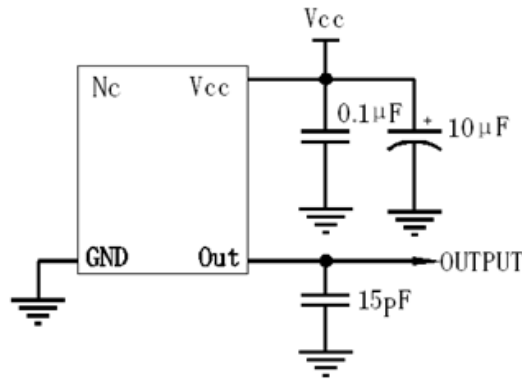

4. Reflow Soldering Curve (RoHS)

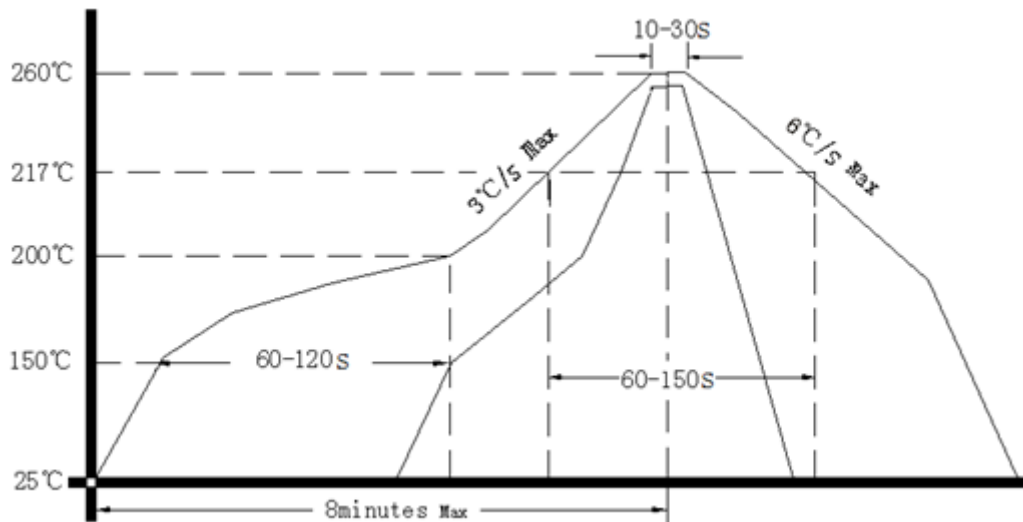

5. Package: Tape & Reel (mm)

