

Customer Code : _____

DATASHEET

DAPU P/N : T936-H412-100.00MHz

P/N : _____

DAPU			Customer Approval
Drew	Audited	Approved	Stamp, please! Thanks!
Date: 2023.12.11			

Guangdong Dapu Telecom Technology Co.,Ltd

Building 5, No.24, Industrial East Road, Songshanhu Park, Dongguan, Guangdong, P.R. China

TEL: 0086-0769-88010888 FAX: 0086-0769-81800098



Table of amendment

Version	Revision contents	Prepared by	Revised date
1.0	The first issued	<i>Amway</i>	2020.06.15
1.1	The “Phase Noise” “Moisture Sensitivity Level” “Mechanical Structure” changed	<i>Amway</i>	2023.03.29
1.2	The “Marking” changed	<i>Amway</i>	2023.12.11



1. Electrical Parameters

MODEL: T936-H412-100.00MHz						
Item	Description	Parameters			Unit	Test Condition
		Min.	Typ.	Max.		
Output	Frequency	100.00			MHz	
	Output Waveform	Sine Wave				
	Level	5			dBm	
	Harmonics Suppression			-30	dBc	
	Spurious Suppression			-60	dBc	
	Load	50			Ω	
Frequency Stabilities	Frequency Tolerance vs. Operating Temperature Range	-0.5		+0.5	$\times 10^{-6}$	T_A varied from -40°C to 85°C , measurement referenced to frequency observed with $f_{\text{ref}} = (f_{\text{max}} + f_{\text{min}}) / 2$, $V_{\text{cc}} = 3.3\text{V}$, $V_c = 1.5\text{V}$, $O_{\text{load}} = 50\Omega$, temperature variable speed less than 2°C per minute.
	Initial Frequency Tolerance	-1		+1	$\times 10^{-6}$	Measurement referenced to frequency observed with $T_A = 25^\circ\text{C}$, $V_{\text{cc}} = 3.3\text{V}$, $V_c = 1.5\text{V}$, and after 15 minutes of operation, within 30 days after ex-works.
	Frequency Tolerance vs. Supply Voltage	-0.1		+0.1	$\times 10^{-6}$	measurement referenced to frequency observed $T_A = 25^\circ\text{C}$, V_{cc} varied from 3.13V to 3.47V, $V_c = 1.5\text{V}$, and $O_{\text{Load}} = 50\Omega$.
	Frequency Tolerance vs. Load	-0.1		+0.1	$\times 10^{-6}$	5% load change measurement referenced to frequency observed with $T_A = 25^\circ\text{C}$, $V_{\text{cc}} = 3.3\text{V}$, $V_c = 1.5\text{V}$, $O_{\text{Load}} = 50\Omega$.
	Aging Tolerance Per Day	-10		+10	$\times 10^{-9}$	TA=25°C, Vcc=3.3V, Vc=1.5V and after 1h of operation.
	Aging Tolerance 1 Year	-1		+1	$\times 10^{-6}$	
	Aging Tolerance 10 Year	-4.6		+4.6	$\times 10^{-6}$	
Power Supply	Current Consumption		30		mA	@25°C, $V_{\text{cc}} = 3.3\text{V}$, $O_{\text{Load}} = 50\Omega$.
	Supply Voltage	3.13	3.3	3.47	V	@25°C



Voltage Control Characteristics	Frequency Tuning Range	-15		-9	$\times 10^{-6}$	$V_c=0.5V$. measurement referenced to $V_c=1.5V$
		-1		+1	$\times 10^{-6}$	$V_c=1.5V$. measurement referenced to exactly 100.00MHz
		+9		+15	$\times 10^{-6}$	$V_c=2.5V$. measurement referenced to $V_c=1.5V$
	Linearity			10	%	
	Slope	Positive				
	Input Impedance	100				K Ω
Phase Noise	Phase Noise @25°C		-80		dBc/Hz	10Hz
			-110			100Hz
			-140			1KHz
			-150			10KHz
			-155			100KHz
Environmental Conditions	Operable Temperature	-40		+85	°C	
	Storage Temperature	-55		+105	°C	
	ESD Level	Human Body Model,class2:2000V to 4000V; ANSI/ESDA/JEDEC JS-001-2010.				
		Machine Model, class B: 200V to 400V; JEDEC JESD22-A115C.				
	Moisture Sensitivity Level	Level 2.				
	Vibration	Test Condition: 0.75mm ;acceleration:10g;10Hz~2000Hz, one cycle per 30 min, test 2 hour. (3 times for each 3 directions X ,Y , Z) .IEC 68-2-06 Test Fc.				
Shock	100g; 6ms; half sine wave (3 times for each 3 directions X ,Y , Z),IEC 68-2-27 Test Ea/Severity 50A.					



2. Mechanical Structure(mm)

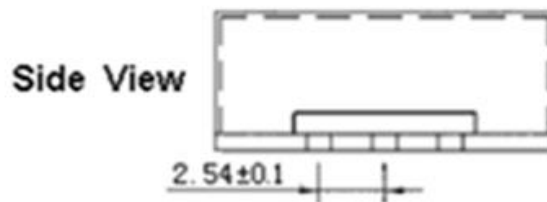
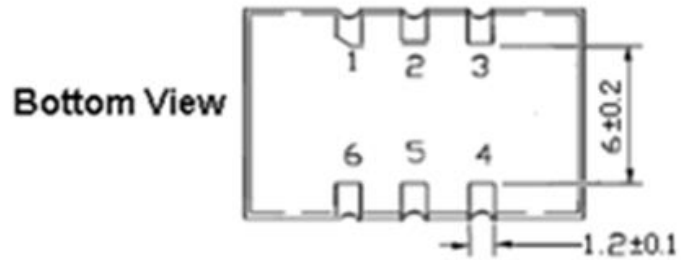

PIN FUNCTION

1	VC
2	NC
3	GND
4	OUTPUT
5	NC
6	VCC

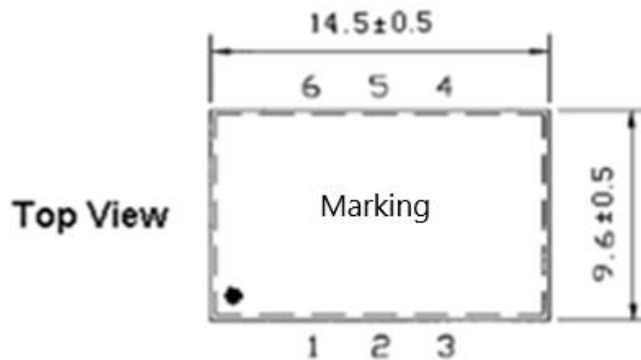

Marking:

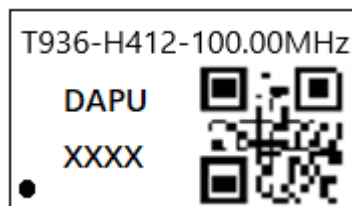

Note1: Tolerance $\pm 0.2\text{mm}$ without mark

Note2: Referential weight 2.2g

Note3: NC is not connect

Note4: The first two xx representative: week
After two xx representative: year



3. Test circuit

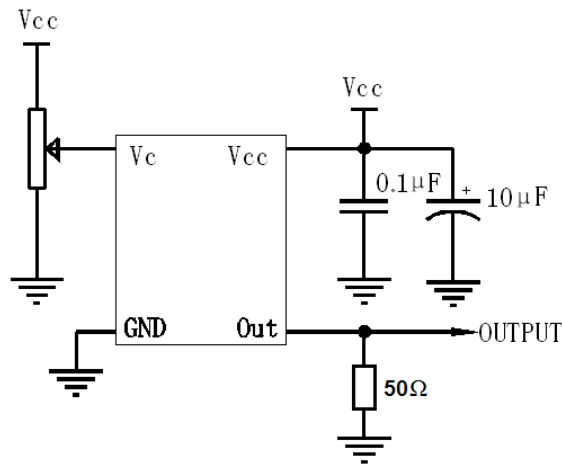

4. Reflow Soldering Curve (RoHS)

