

CUSTOMER: \_\_\_\_\_

# DATASHEET

PRODUCT TYPE:                   DPTC3225                  

DAPU P/N:           T3225C-B589-32.00MHz-N          

Plot			The Label
Drew	Audited	Approved	Stamp, please! Thanks!
LIN Jianhua	David	William	
Date: 2023.07.11			

**Guangdong Dapu Telecom Technology Co.,Ltd**

Building 5, No.24, Industrial East Road, Songshanhu Park, Dongguan, Guangdong, P.R. China

TEL: 0086-0769-88010888 FAX: 0086-0769-81800098

**Table of amendment**

Version	Revision contents	Prepared by	Revised date
1.0	The first issued	LIN Jianhua	2023.07.11



## 1. Electrical Parameters

MODEL: T3225C-B589-32.00MHz-N						
Item	Description	Parameters			Unit	Test Condition
		Min.	Typ.	Max.		
Output	Frequency	32.00			MHz	
	Output Waveform	Clipped Sine Wave				
	Vp-p	0.8			V	
	Spurious Suppression		-10	-8	dBc	
	Load	10KΩ//10pF				
Frequency Stabilities	Frequency Tolerance	-1.5		+1.5	$\times 10^{-6}$	@25±2°C, 2H, after 2 times reflow soldering, base on nominal frequency.
	vs. Temperature	-2		+2	$\times 10^{-6}$	T <sub>A</sub> varied from -40°C to 85°C, measurement referenced to frequency observed with f <sub>ref</sub> =(f <sub>max</sub> +f <sub>min</sub> )/2, V <sub>cc</sub> =3.3V, O <sub>load</sub> =10KΩ//10pF, temperature variable speed less than 2°C per minute.
	vs. Supply Voltage	-0.1		+0.1	$\times 10^{-6}$	measurement referenced to frequency observed T <sub>A</sub> =25°C, V <sub>cc</sub> = 3.3±5%, and O <sub>Load</sub> =10KΩ//10pF.
	vs. Load	-0.1		+0.1	$\times 10^{-6}$	10% load change measurement referenced to frequency observed with T <sub>A</sub> =25°C, V <sub>cc</sub> =3.3V, and O <sub>Load</sub> =10KΩ//10pF .
	Aging Tolerance 1 Year	-1		+1	$\times 10^{-6}$	T <sub>A</sub> =25°C, V <sub>cc</sub> =3.3V, and after 1h of operation.
	Aging Tolerance 2Year	-2		+2	$\times 10^{-6}$	
	Aging Tolerance 10 Year	-4		+4	$\times 10^{-6}$	
	Frequency Slope	-0.1		0.1	ppm/°C	TA varied from -40°C to 85°C
Power Supply	Current consumption			3	mA	@25°C, V <sub>cc</sub> =3.3V, O <sub>Load</sub> =10KΩ//10pF.
	Start up Time			2	ms	More than 90% of final output voltage
	Supply Voltage	2.52	2.8	3.08	V	
SSB Phase Noise	Phase Noise@25±2°C			-40	dBc/Hz	1Hz
				-76		10Hz
				-108		100Hz
				-135		1KHz
				-145		10KHz
				-152		100KHz
				-152		1MHz



Environmental Conditions	Operable Temperature	-40		+85	°C	
	Storage Temperature	-55		+125	°C	
	ESD Level	Human Body Model, class2: 2000V; ANSI/ESDA/JEDEC JS-001-2010.				
		Machine Model, class B: 200V; JEDEC JESD22-A115C.				
	Moisture Sensitivity Level	Level 1.				
	Vibration	Test Condition: 0.75mm ;acceleration:10g;10Hz~2000Hz, one cycle per 30 min, test 2 hour. (3 times for each 3 directions X ,Y , Z ) .IEC 68-2-06 Test Fc.				
Shock	100g; 6ms; half sine wave (3 times for each 3 directions X ,Y , Z ),IEC 68-2-27 Test Ea/Severity 50A.					
Full Package Storage	Relative humidity (%)	20%~70%				
	Temperature (°C)	-10~35°C				

**2. Mechanical Structure(mm)**

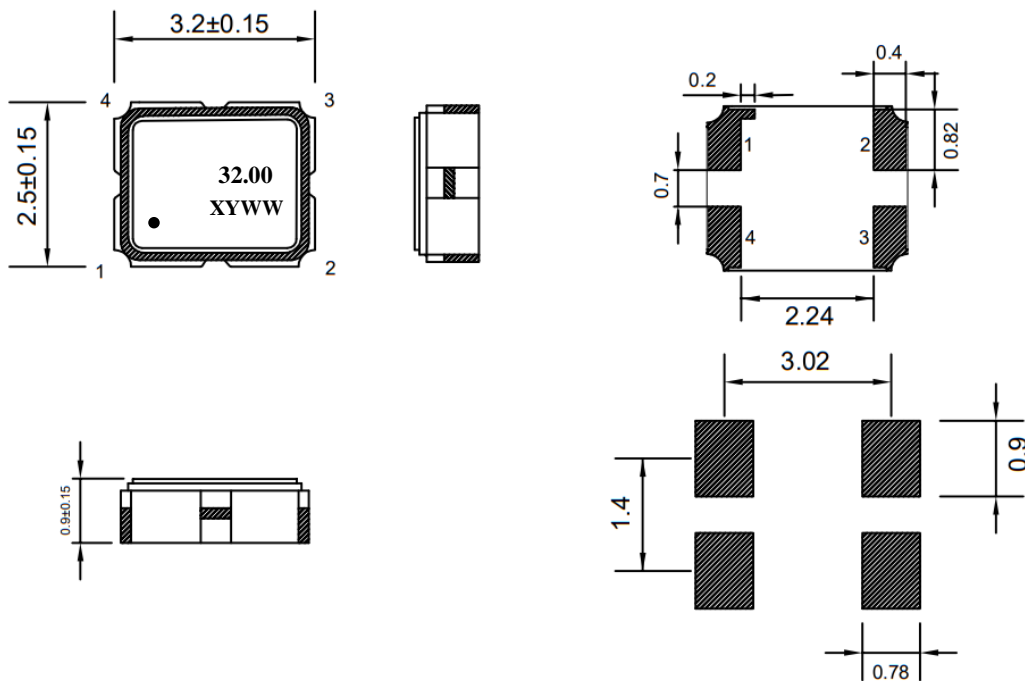

PIN NAME	CONNECTION
PIN1	NC
PIN2	GND
PIN3	OUTPUT
PIN4	VCC

Note1: N/C is not connected



### 3. Marking Information

<p><b>32.00: Frequency 32.00Mhz</b>  <b>X: Lot No.</b>  <b>Y: Year</b>  <b>WW: Week</b>  <b>● : Pin1 Index</b></p>	
--	--

### 4. Test Circuit

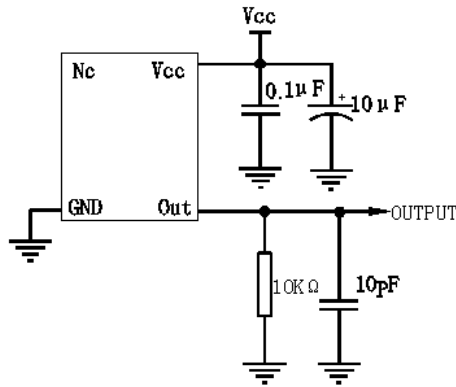

### 5. Reflow Soldering Curve (RoHS)

