

Travelling Merchant: _____

DATASHEET

Standard: **079A-C319-19.44MHz-G025**

P/N: _____

Plot			The Label
Drew	Audited	Approved	Stamp, please! Thanks!
Date: 2023.12.15			

Guangdong Dapu Telecom Technology Co.,Ltd

Building 5, No.24, Industrial East Road, Songshanhu Park, Dongguan, Guangdong, P.R. China

TEL: 0086-0769-88010888 FAX: 0086-0769-81800098



Table of amendment

Version	Revision contents	Prepared by	Revised date
1.0	The first issued	<i>Amway</i>	2023.11.15
1.1	The “Marking” changed	<i>Amway</i>	2023.12.15



1. Electrical Parameters

MODEL: O79A-C319-19.44MHz-G025						
Item	Description	Parameters			Unit	Test Condition
		Min.	Typ.	Max.		
Output	Frequency	19.44			MHz	
	Output Waveform	LVCMOS				
	Output Low Voltage			0.4	V	$V_{cc}=3.3V, O_{load}=15\text{ pF}$
	Output High Voltage	2.97			V	$V_{cc}=3.3V, O_{load}=15\text{ pF}$
	Duty Cycle	45	50	55	%	@50%
	Start up Time			10	ms	
	Rise / Fall Time (10%~90%)			4	ns	@25°C
	Load	15			pF	
Frequency Stabilities	Free-run accuracy	-4.6		+4.6	$\times 10^{-6}$	Including all causes in 20 years, reference to nominal frequency.
	Frequency Tolerance vs. Operating Temperature Range	-0.02		+0.02	$\times 10^{-6}$	T_A varied from -40°C to 85°C, measurement referenced to frequency observed with $f_{ref}=(f_{max}+f_{min})/2, V_{cc}=3.3V, O_{load}=15\text{ pF}$, temperature variable speed less than 2°C per minute.
	Initial Frequency Tolerance	-1.5		+1.5	$\times 10^{-6}$	Measurement referenced to frequency observed with $T_A=25^\circ\text{C}, V_{cc}=3.3V$ within 30 days after ex-works.
	Frequency Tolerance vs. Supply Voltage	-0.01		+0.01	$\times 10^{-6}$	measurement referenced to frequency observed $T_A=25^\circ\text{C}, V_{cc}$ varied from 3.13V to 3.47V, and $O_{Load}=15\text{ pF}$.
	Frequency Tolerance vs. Load	-0.01		+0.01	$\times 10^{-6}$	5% load change measurement referenced to frequency observed with $T_A=25^\circ\text{C}, V_{cc}=3.3V, O_{Load}=15\text{ pF}$.
	Frequency Slope (in still air)	-1.5		+1.5	$\times 10^{-9}/^\circ\text{C}$	Temperature ramp $\leq 0.5^\circ\text{C}/\text{minute}$
	Reflow Shift	-1		+1	$\times 10^{-6}$	After 1hour at 25°C
	Aging Tolerance Per Day	-3		+3	$\times 10^{-9}$	$T_A=25^\circ\text{C}, V_{cc}=3.3V$, and after 30days of operation.
	Aging Tolerance First Year	-0.8		+0.8	$\times 10^{-6}$	
	Aging Tolerance 20 Years	-2		+2	$\times 10^{-6}$	



	Short Term Stability		0.02	0.07	$\times 10^{-9}$	Temperature stability, no EMI/EMC or other interference, test after power for 1hour ref. to 25°C; 1s.
	Holdover (in still air)			5	$\times 10^{-9}$	After 30 days of operation, reference to F(t=0),24hours.
Power Supply	Steady Consumption			200	mA	@25°C
	Warm Up Current			600	mA	
	Supply Voltage	3.13	3.3	3.47	V	
	Warm Up Time			5	Min	@25 °C within $\pm 0.1 \times 10^{-6}$ of final frequency with reference after 1 hour on.
Phase Noise	Phase Noise @25°C		-77	-70	dBc/Hz	1Hz
			-109	-105		10Hz
			-140	-135		100Hz
			-152	-147		1KHz
			-160	-155		10KHz
			-160	-155		100KHz
			-160	-155		1MHz
Jitter	Jitter		0.35		ps	RMS,12kHz~5MHz
Environmental Conditions	Operable Temperature	-40		+85	°C	
	Storage Temperature	-55		+105	°C	
	ESD Level	Human Body Model,class2: 2000V to 4000V; ANSI/ESDA/JEDEC JS-001-2010.				
		Machine Model, class B: 200V to 400V; JEDEC JESD22-A115C.				
	Moisture Sensitivity Level	Level 1.				
	Vibration	Test Condition: 0.75mm ;acceleration:10g;10Hz~2000Hz, one cycle per 30 min, test 2 hour. (3 times for each 3 directions X , Y , Z) .IEC 68-2-06 Test Fc.				
Shock	100g; 6ms; half sine wave (3 times for each 3 directions X , Y , Z),IEC 68-2-27 Test Ea/Severity 50A.					



2. Mechanical Structure(mm)

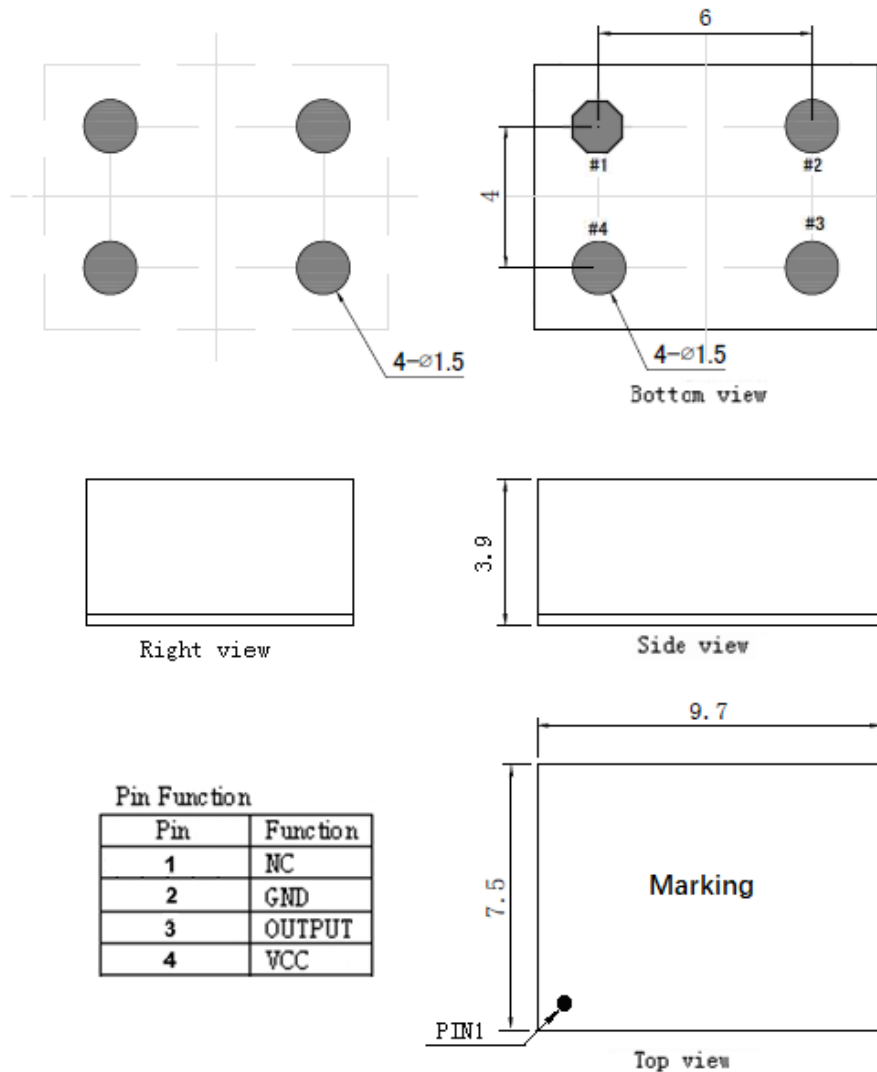

Marking:



Note1: Tolerance ± 0.3 mm without mark

Note2: Where YY is 23 for 2023 and WW is 2 digit character for the week of production

Note3: The content of the QR code is only for the purpose of the tracing individual product production information.

Note4: Referential Weight 0.7g

Note5: NC is not connect



3. Test circuit



4. Reflow Soldering Curve (RoHS)

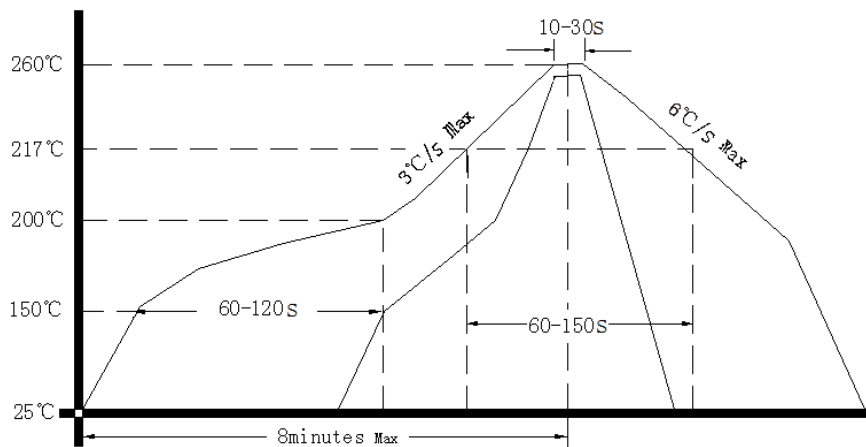

Note: Passing through reflow upside down is not supported

5. Package: Tape & Reel (mm)

