

Customer Code : _____

DATASHEET

DAPU P/N: **O11L-L429-100.00MHZ-G289**

Customer P/N: _____

DAPU			Customer Approval
Drew	Audited	Approved	Stamp, please! Thanks!
Date: 2023.11.03			

Guangdong Dapu Telecom Technology Co.,Ltd

Building 5, No.24, Industrial East Road, Songshanhu Park, Dongguan, Guangdong, P.R. China

TEL: 0086-0769-88010888 FAX: 0086-0769-81800098



Table of amendment

Version	Revision contents	Prepared by	Revised date
1.0	The first issued	<i>Amway</i>	2023.11.03



1. Electrical Parameters

MODEL: O11L-L429-100.00MHz-G289						
Item	Description	Parameters			Unit	Test Condition
		Min.	Typ.	Max.		
Output	Frequency	100.00			MHz	
	Output Waveform	Sine Wave				
	Level	7			dBm	
	Harmonics Suppression			-25	dBc	
	Load	50			Ω	
Frequency Stabilities	Frequency Tolerance vs. Operating Temperature Range	-0.05		+0.05	$\times 10^{-6}$	T_A varied from -40°C to 85°C , measurement referenced to frequency observed with $f_{\text{ref}}=(f_{\text{max}}+f_{\text{min}})/2$, $V_{\text{cc}}=5.0\text{V}$, $O_{\text{load}}=15\text{pF}$, temperature variable speed less than 2°C per minute.
	Initial Frequency Tolerance	-0.1		+0.1	$\times 10^{-6}$	Measurement referenced to frequency observed with $T_A=25^\circ\text{C}$, $V_{\text{cc}}=5.0\text{V}$, and after 5 minutes of operation, within 30 days after ex-works.
	Frequency Tolerance vs. Supply Voltage	-2		+2	$\times 10^{-9}$	measurement referenced to frequency observed $T_A=25^\circ\text{C}$, V_{cc} varied from 4.75V to 5.25V, and $O_{\text{load}}=50\Omega$.
	G-Sensitivity	± 0.2		± 1	$\times 10^{-9}/\text{G}$	worst direction, 0 – 1kHz vibration BW(for 0 - 2kHz BW height of OCXO 10.5mm)
	Retrace	-0.02		+0.02	$\times 10^{-6}$	
	Allan Deviation			0.05	$\times 10^{-9}$	1s
	Aging Tolerance Per Day	-3		+3	$\times 10^{-9}$	V_{cc}, T_A constant measurement referenced to frequency observed with $T_A=25^\circ\text{C}$, $V_{\text{cc}}=5.0\text{V}$, and after 30 days of operation.
	Aging Tolerance 1 Year	-0.3		+0.3	$\times 10^{-6}$	
Power Supply	Supply Voltage	4.75	5.0	5.25	V	
	Steady Consumption		36		mA	
	Warm up current			240	mA	@ 25°C
	Warm-Up Time		60	90	S	@ 25°C within $\pm 0.1 \times 10^{-6}$ of final frequency with reference after 15 minutes on.



Phase Noise	Phase Noise			-90	dBc/Hz	10Hz
				-120		100Hz
				-150		1KHz
				-165		10KHz
				-165		100KHz
Environmental Conditions	Operable Temperature	-40		+85	°C	
	Storage Temperature	-55		+125	°C	
	ESD Level	Human Body Model, class2: 2000V to 4000V; ANSI/ESDA/JEDEC JS-001-2010.				
		Machine Model, class B: 200V to 400V; JEDEC JESD22-A115C.				
	Moisture Sensitivity Level	Not humidity sensitive.				
	Vibration	Test Condition: 0.75mm ;acceleration:10g;10Hz~500Hz, one cycle per 30 min, test 2 hour. (3 times for each 3 directions X , Y , Z), IEC 68-2-06 Test Fc.				
Shock	50g; 11ms; half sine wave (3 times for each 3 directions X, Y, Z), IEC 68-2-27 Test Ea/Severity 50A.					
Full Package Storage	Relative humidity (%)	20% ~70%				
	Temperature (°C)	-10~35°C				



2. Mechanical Structure (mm)

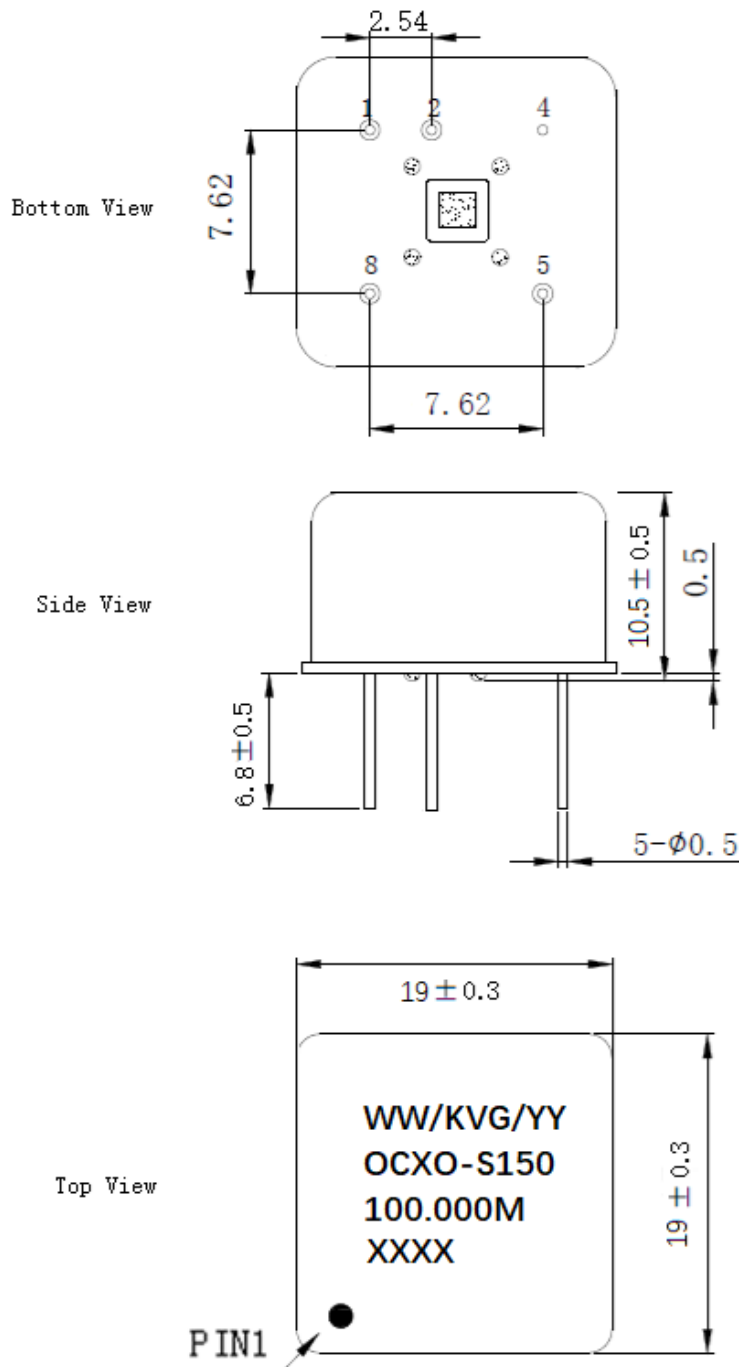

PIN FUNCTION

PIN	FUNCTION
1	VC
2	NC
4	GND
5	OUTPUT
8	VCC

Top View

Note1: Tolerance ± 0.20 mm without mark

Note2: The first two WW representative: week

After two YY representative: year

Last four XXXX is Serial Number

Note3: Referential weight 5.0g



3. Test Circuit

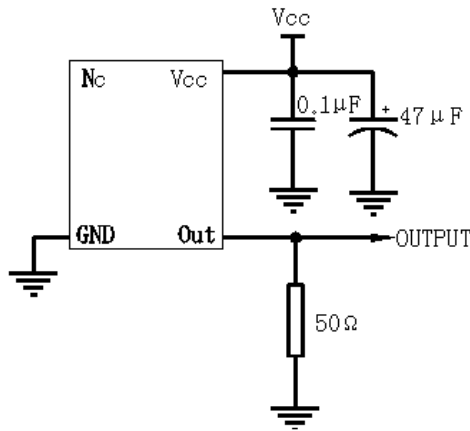

4. Reflow Soldering Curve (RoHS)

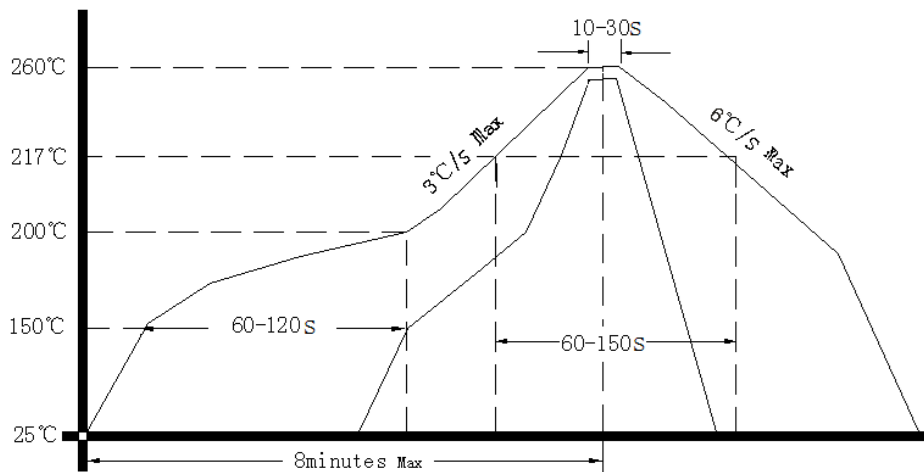

5. Package: Tape & Reel (mm)

