

Travelling Merchant: _____

DATASHEET

Standard: DPBA100M0001

Plot			The Label
Drew	Audited	Approved	Stamp, please! Thanks!
Date: 2023.09.27			

Guangdong Dapu Telecom Technology Co.,Ltd

Building 5, No.24, Industrial East Road, Songshanhu Park, Dongguan, Guangdong, P.R. China

TEL: 0086-0769-88010888 FAX: 0086-0769-81800098



1、Electrical Parameters

MODEL: DPBA100M0001							
No.	Parameters	SYM.	Electrical Spec.				Notes
			Min.	Typ.	Max.	Units	
1	Nominal Frequency	FL	100.00			MHz	
2	Frequency Tolerance	-	-30	~	+30	$\times 10^{-6}$	
3	Operating Temperature	Topr	-40	~	+85	$^{\circ}\text{C}$	
4	Storage Temperature	Tstg	-55	~	+125	$^{\circ}\text{C}$	
5	Supply Voltage	Vdd	1.8		3.3	V	
6	Input Current	Icc	-	-	110	mA	
7	Output waveform	-	LVPECL			-	
8	Output Load:	CL		50		Ω	
9	Voltage Vol (Max.) / Voh Min.)		Vdd-1.62		Vdd-1.025	V	
10	High Level Input Voltage	VIH	70%Vdd	-	-	V	
11	Low Level Input Voltage	VIL	-	-	30%Vdd	V	
12	Rise/ Fall Time	Tr/ Tf	-	-	1.5	ns	20%~80% Vdd Level
13	Symmetry (Duty ratio)	TH/T	40		60	%	
14	Start-up Time	Tosc	-	-	10	ms	

2、Mechanical Structure(mm)

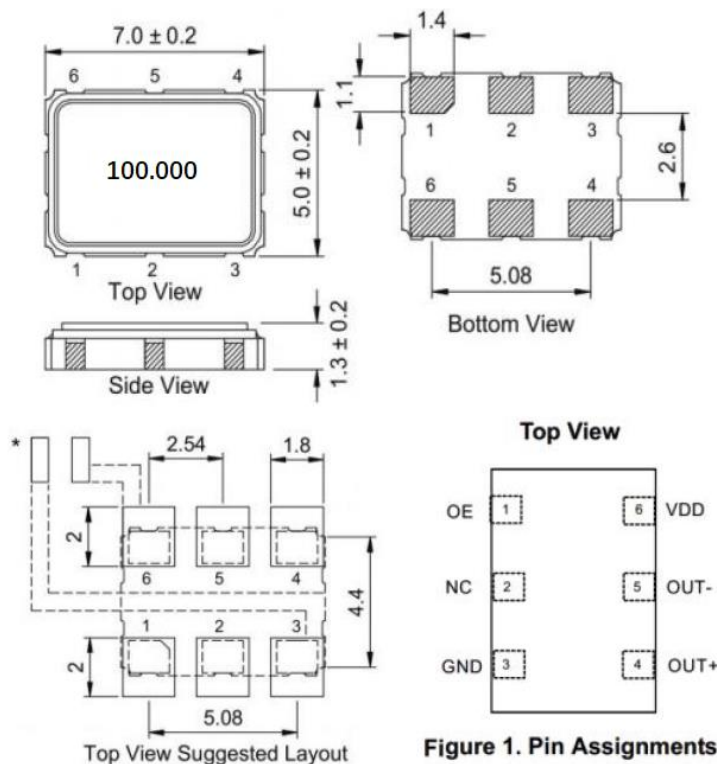

Note1: Tolerance $\pm 0.2\text{mm}$ without mark



3、 Test Circuit

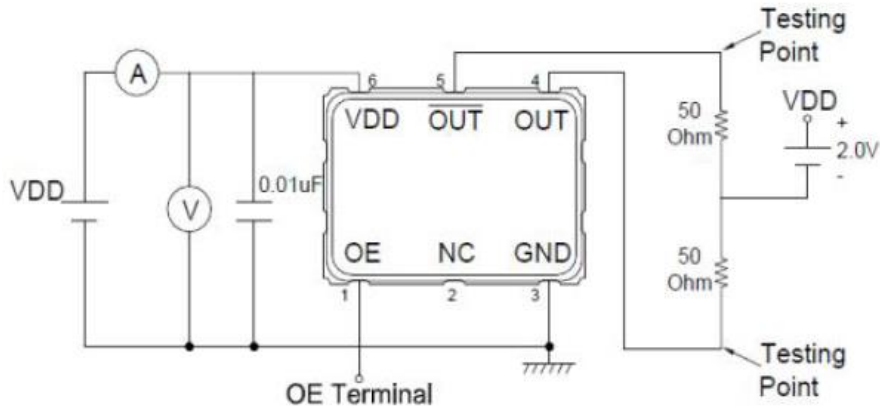

4、 Reflow Soldering Curve (RoHS)

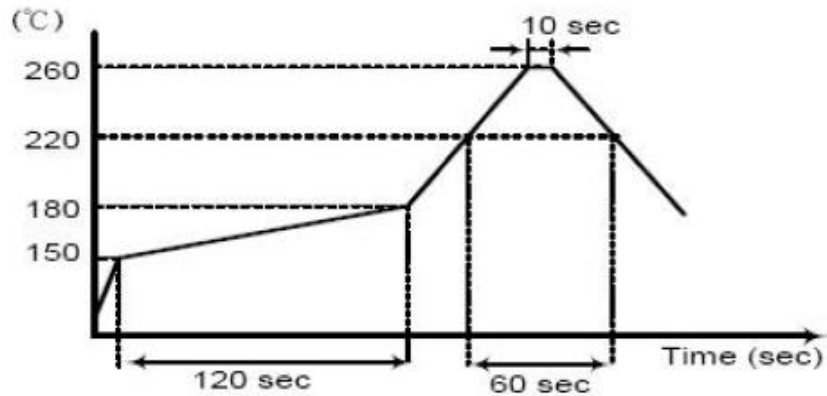

5、 Package: Tape & Reel (mm)

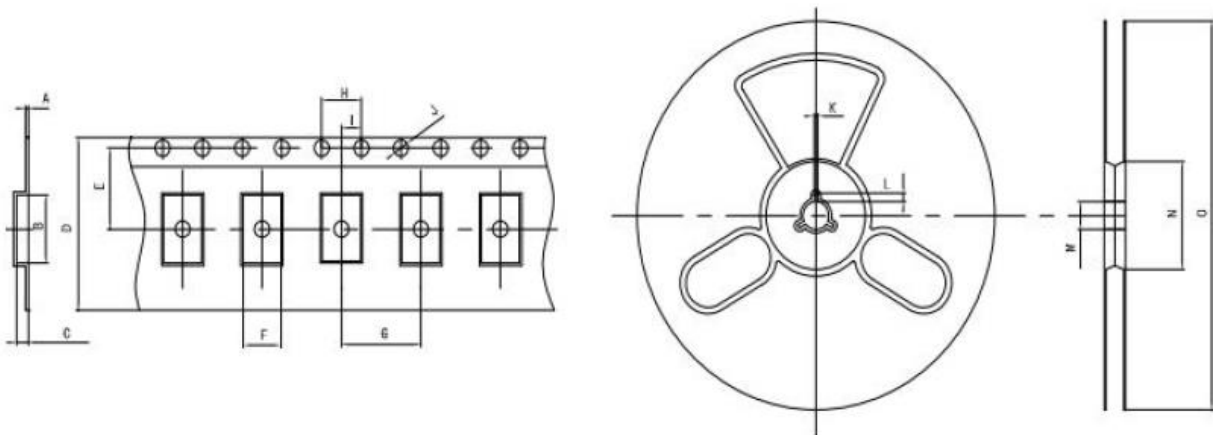

TEYE	A	B	C	D	E	F	G	H	I	J	K	L	M	N	O
5×7 SMD	0.3	7.5	2.0	16.0	7.5	5.5	8.0	4.0	2.0	1.5	2.0	4.0	13.0	60.0	180.0