

Customer Code : \_\_\_\_\_

# DATASHEET

DAPU P/N :     **T32-S519-52.00MHz**    

Customer P/N: \_\_\_\_\_

DAPU			Customer Approval
Drew	Audited	Approved	Stamp, please! Thanks!
Date: 2023.09.26			

## Guangdong Dapu Telecom Technology Co.,Ltd

Building 5, No.24, Industrial East Road, Songshanhu Park, Dongguan, Guangdong, P.R. China

TEL: 0086-0769-88010888 FAX: 0086-0769-81800098





## 1. Electrical Parameters

MODEL: T32-S519-52.00MHz						
Item	Description	Parameters			Unit	Test Condition
		Min.	Typ.	Max.		
Output	Frequency	52.00			MHz	
	Output Waveform	Clipped Sine Wave				
	Vp-p	0.8			V	
	Start Up Time			2	ms	@90% of final Vout level
	Symmetry	40	50	60	%	
	Load	10KΩ//10pF				
Frequency Stabilities	Frequency Tolerance vs. Operating Temperature Range	-0.5		+0.5	$\times 10^{-6}$	T <sub>A</sub> varied from -40 to 85°C, measurement referenced to frequency observed with $f_{ref}=(f_{max}+f_{min})/2$ , V <sub>cc</sub> =3.3V, O <sub>load</sub> =10KΩ//10pF, temperature variable speed less than 2°C per minute.
	Initial Frequency Tolerance	-1		+1	$\times 10^{-6}$	Measurement referenced to frequency observed with T <sub>A</sub> =25°C, V <sub>cc</sub> =3.3V, within 30 days after ex-works.
	Frequency Tolerance vs. Supply Voltage	-0.2		+0.2	$\times 10^{-6}$	measurement referenced to frequency observed T <sub>A</sub> =25°C, V <sub>cc</sub> varied from 3.135V to 3.465V, and O <sub>Load</sub> =10KΩ//10pF.
	Frequency Tolerance vs. Load	-0.2		+0.2	$\times 10^{-6}$	10% load change measurement referenced to frequency observed with T <sub>A</sub> =25°C, V <sub>cc</sub> =3.3V, O <sub>Load</sub> =10KΩ//10pF
	Aging Tolerance Per Day	-0.02		+0.02	$\times 10^{-6}$	T <sub>A</sub> =25°C, V <sub>cc</sub> =3.3V, and after 1h of operation.
	Aging Tolerance 1 Year	-1		+1	$\times 10^{-6}$	
Power Supply	Current Consumption			3	mA	@25°C, V <sub>cc</sub> =3.3V, O <sub>load</sub> =10KΩ//10pF.
	Supply Voltage	3.135	3.3	3.465	V	



Phase Noise	Phase Noise @25°C		-75	-80	dBc/Hz	10Hz
			-100	-95		100Hz
			-130	-125		1KHz
			-140	-135		10KHz
			-145	-140		100KHz
			-150	-145		1MHz
Environmental Conditions	Operable Temperature	-40		+85	°C	
	Storage Temperature	-55		+125	°C	
	ESD Level	Human Body Model, class2: 2000V to 4000V; ANSI/ESDA/JEDEC JS-001-2010.				
		Machine Model, class B: 200V to 400V; JEDEC JESD22-A115C.				
	Moisture Sensitivity Level	Level 1.				
	Vibration	Test Condition: 0.75mm ;acceleration:10g;10Hz~2000Hz, one cycle per 30 min, test 2 hour. (3 times for each 3 directions X , Y , Z ).IEC 68-2-06 Test Fc.				
Shock	100g; 6ms; half sine wave (3 times for each 3 directions X , Y , Z ),IEC 68-2-27 Test Ea/Severity 50A.					
Full Package Storage	Relative humidity (%)	20% ~70%				
	Temperature (°C)	-10~35°C				



## 2. Mechanical Structure(mm)

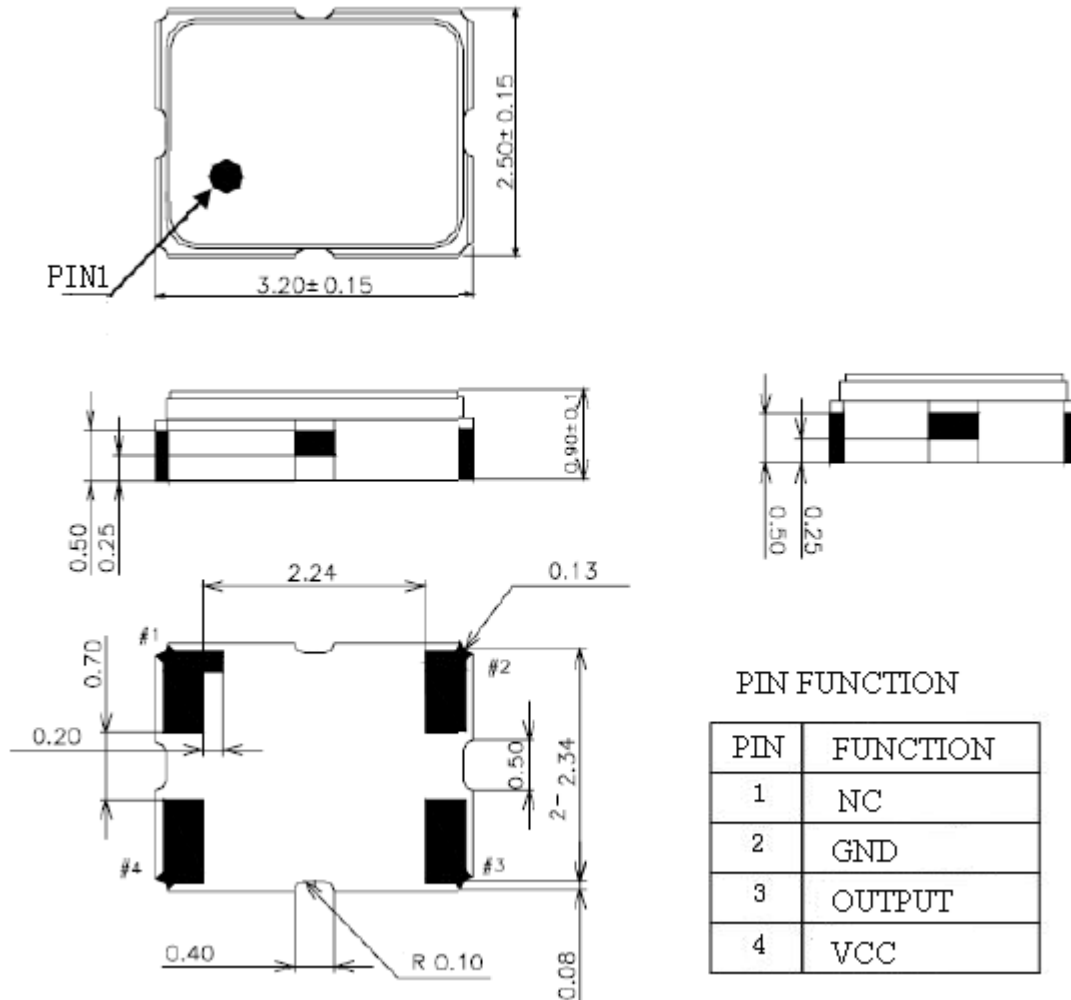

**Note1:** Tolerance  $\pm 0.2$ mm without mark

**Note2:** Referential weight 0.02g

**Note3:** NC is not connect



### 3. Test circuit

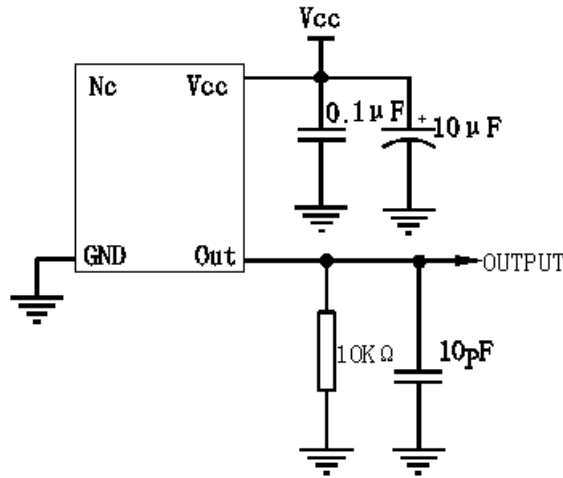

### 4. Reflow Soldering Curve (RoHS)

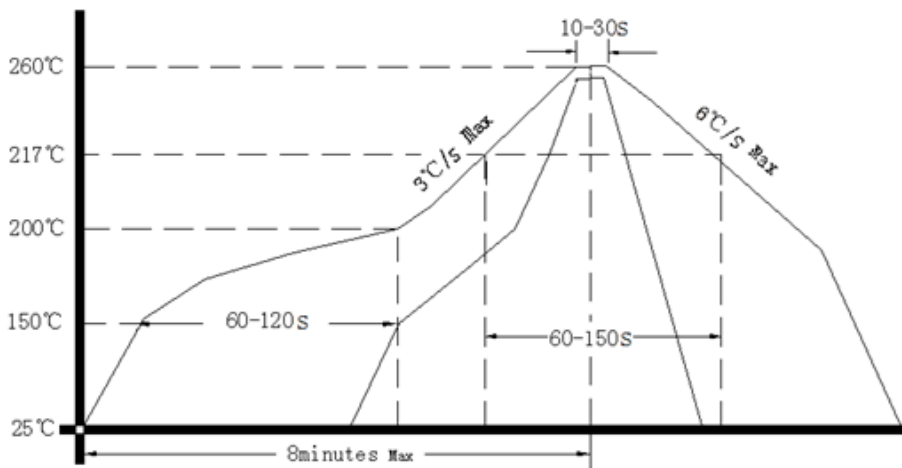

### 5. Package: Tape & Reel (mm)

