

Travelling Merchant: _____

DATASHEET

Standard: DP9B3579545002

Plot			The Label
Drew	Audited	Approved	Stamp, please! Thanks!
Date: 2023.06.16			

Guangdong Dapu Telecom Technology Co.,Ltd

Building 5, No.24, Industrial East Road, Songshanhu Park, Dongguan, Guangdong, P.R. China

TEL: 0086-0769-88010888 FAX: 0086-0769-81800098



Table of amendment

Version	Revision contents	Prepared by	Revised date
1.0	The first issued	<i>Amway</i>	2023.06.16

DAPU Confidential



1、Electrical Parameters

MODEL: DP9B3579545002							
No.	Parameters	SYM.	Electrical Spec.				Notes
			Min.	Typ.	Max.	Units	
1	Nominal Frequency	FL	3.579545			MHz	AT-CUT
2	Oscillation Mode	-	Fundamental			-	
3	Load Capacitance	CL	20			pF	
4	Frequency Tolerance	-	-20	-	+20	$\times 10^{-6}$	at 25°C ± 2°C
5	Tolerance over the Temperature Range	-	-30	-	+30	$\times 10^{-6}$	Reference 25°C
6	Operating Temperature Range	-	-40	~	+85	°C	
7	Storage Temperature	-	-40	~	+105	°C	
8	Aging	-	-5	-	+5	$\times 10^{-6}$	1st Year
9	Drive Level	DL	-	100	-	uW	
10	Effective Series Resistance	ESR	-	-	100	Ω	
11	Shunt Capacitance C0	C0	-	-	7	pF	
12	Insulation Resistance	-	500	-	-	M Ω	at DC 100V
13	SPDB	-	-	-	-3	dB	F0+/-500KHz

2. Mechanical Structure

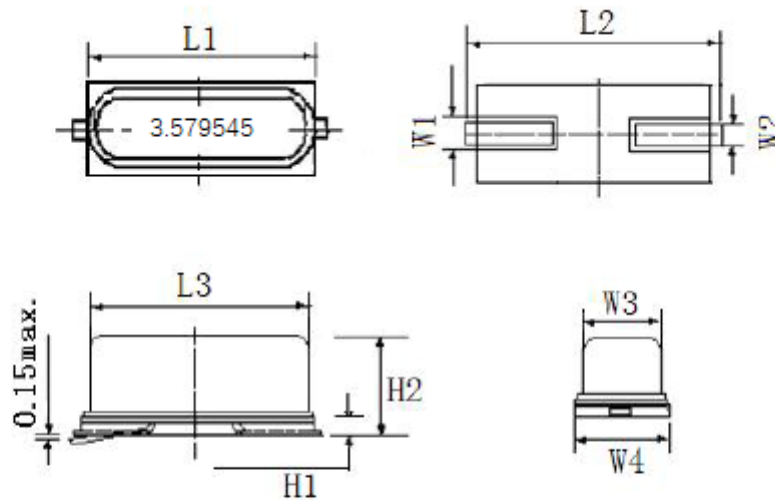

L1	L2	L3	H1	H2
11.4 ± 0.3	12.6 ± 0.3	9.85 ± 0.2	0.55 ± 0.05	3.8 ± 0.3
W1	W2	W3	W4	
0.95 ± 0.2	0.75 ± 0.2	3.5 ± 0.2	4.7 ± 0.2	