

Travelling Merchant: \_\_\_\_\_

# DATASHEET

Standard:           **O23A-F448-10.00MHz-ACT**          

P/N: \_\_\_\_\_

Plot			The Label
Drew	Audited	Approved	Stamp, please! Thanks!
Date: 2023.05.19			

## Guangdong Dapu Telecom Technology Co.,Ltd

Building 5, No.24, Industrial East Road, Songshanhu Park, Dongguan, Guangdong, P.R. China

TEL: 0086-0769-88010888    FAX: 0086-0769-81800098



### Table of amendment

Version	Revision contents	Prepared by	Revised date
1.0	The first issued	<i>Amway</i>	2023.05.19



## 1. Electrical Parameters

MODEL: O23A-F448-10.00MHz-ACT						
Item	Description	Parameters			Unit	Test Condition
		Min.	Typ.	Max.		
Output	Frequency	10.00			MHz	
	Output Waveform	Sine wave				
	Level	6		10	dBm	
	Load	50			$\Omega$	
	Harmonics Suppression			-30	dBc	
	Spurious Suppression			-60	dBc	
Frequency Stabilities	Frequency Tolerance vs. Operating Temperature Range	-5		+5	$\times 10^{-9}$	$T_A$ varied from $-40^\circ\text{C}$ to $85^\circ\text{C}$ , measurement referenced to frequency observed with $T_A=25^\circ\text{C}$ , $V_{cc}=12.0\text{V}$ , $O_{load}=50\Omega$ , temperature rise speed less than $2^\circ\text{C}$ per minute.
	Initial Frequency Tolerance	-0.05		+0.05	$\times 10^{-6}$	Measurement referenced to frequency observed with $T_A=25^\circ\text{C}$ , $V_{cc}=12.0\text{V}$ , $V_c=2.5\text{V}$ and after 15 minutes of operation, within 30 days after ex-works.
	Frequency Tolerance vs. supply voltage	-2		+2	$\times 10^{-9}$	measurement referenced to frequency observed $T_A=25^\circ\text{C}$ , $V_{cc}$ varied from 11.4V to 12.6V, $V_c=2.5\text{V}$ , $O_{load}=50\Omega$ .
	Frequency Tolerance vs. Load	-2		+2	$\times 10^{-9}$	5% Load Change Measurement referenced to frequency observed with $T_A=25^\circ\text{C}$ , $V_{cc}=12.0\text{V}$ , $V_c=2.5\text{V}$ , $O_{load}=50\Omega$ .
	Short Term Stability			0.01	$\times 10^{-9}$	Temperature stability, no EMI\EMC or other interference, test after power for 1hour ref. to $25^\circ\text{C}$ ; 1s.
	Aging Tolerance per day	-0.5		+0.5	$\times 10^{-9}$	$V_{cc}, V_c, T_A$ constant Measurement referenced to frequency observed with $T_A=25^\circ\text{C}$ , $V_{cc}=12.0\text{V}$ , $V_c=2.5\text{V}$ , $O_{load}=50\Omega$ and after 30 days of operation.
	Aging Tolerance 1Year	-0.05		+0.05	$\times 10^{-6}$	
Power Supply	Supply Voltage	11.4	12.0	12.6	V	
	Current Consumption			150	mA	@ $25^\circ\text{C}$
	Current Consumption during warm up			350	mA	



Voltage Control Characteristics	Frequency Tuning Range			-1.0	$\times 10^{-6}$	$V_c=0V$ . measurement referenced to $V_c=2.5V$ .
		-0.05		+0.05	$\times 10^{-6}$	$V_c=2.5V$ . measurement referenced to exactly 10.00MHz.
		+1.0			$\times 10^{-6}$	$V_c=5.0V$ . measurement referenced to $V_c=2.5V$ .
	Linearity			10	%	
	Slope	Positive				
	Input Impedance	100				K $\Omega$
Phase Noise	Phase Noise		-150	-147	dBc/Hz	1KHz
			-155	-152		10KHz
			-155	-152		100KHz
Environmental Conditions	Operable Temperature	-40		+85	$^{\circ}C$	
	Storage Temperature	-55		+105	$^{\circ}C$	
	ESD Level	Human Body Model, class2: 2000V to 4000V; ANSI/ESDA/JEDEC JS-001-2010.				
		Machine Model, class B: 200V to 400V; JEDEC JESD22-A115C.				
	Moisture Sensitivity Level	Not humidity sensitive.				
	Vibration	Test Condition: 0.75mm ;acceleration:10g;10Hz~500Hz, one cycle per 30 min, test 2 hour. (3 times for each 3 directions X ,Y , Z), IEC 68-2-06 Test Fc.				
Shock	50g; 11ms; half sine wave (3 times for each 3 directions X ,Y, Z ),IEC 68-2-27 Test Ea/Severity 50A.					



## 2. Mechanical Structure (mm)

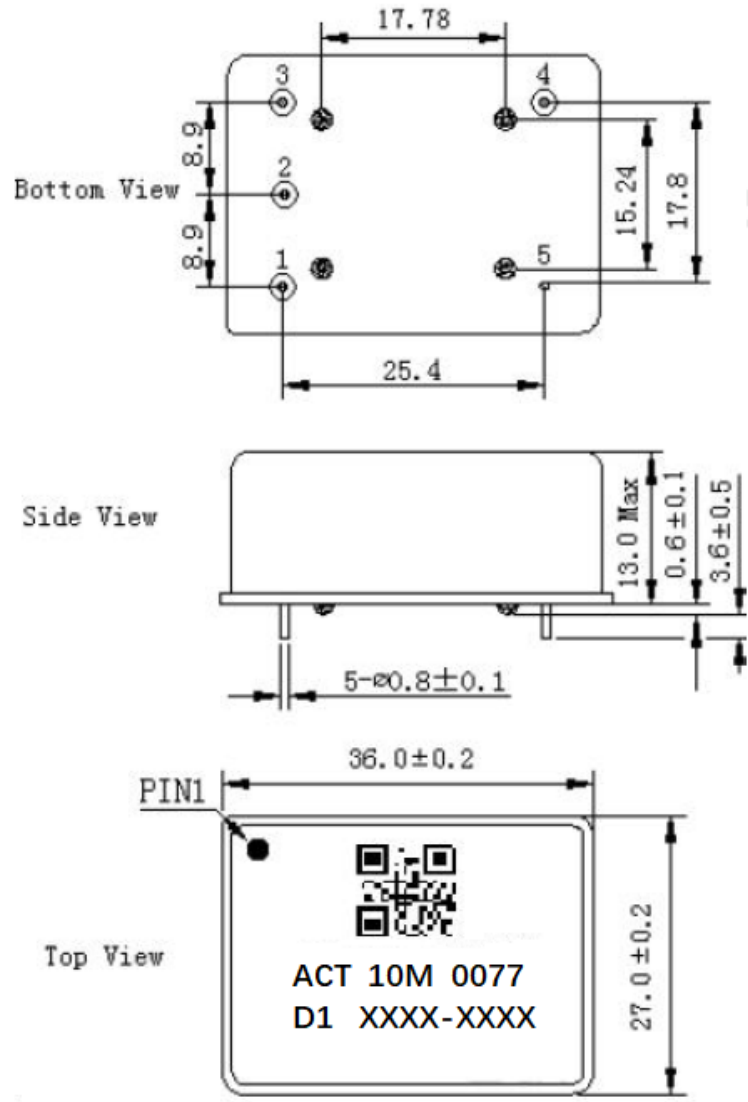

### PIN FUNCTION

PIN	NOTATION	FUNCTION
1	VC	Control Voltage
2	NC	Not Connect
3	VCC	Supply Voltage
4	OUTPUT	RF Output
5	GND	GND

**Note1:** Tolerance ± 0.2mm without mark

**Note2:** The first two xx representative: week

After two xx representative: year

At last four xxxx representative: serial number

**Note3:** Referential Weight 21g

**Note4:** NC is not connect



### 3. Test Circuit

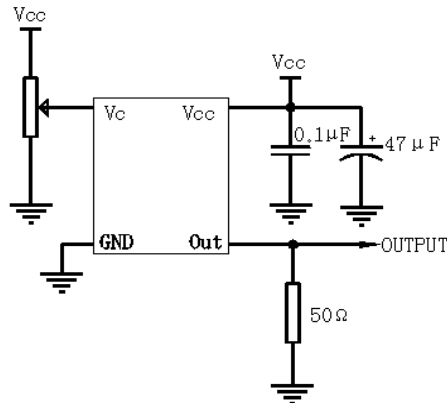

### 4. Wave Soldering Curve (RoHS)

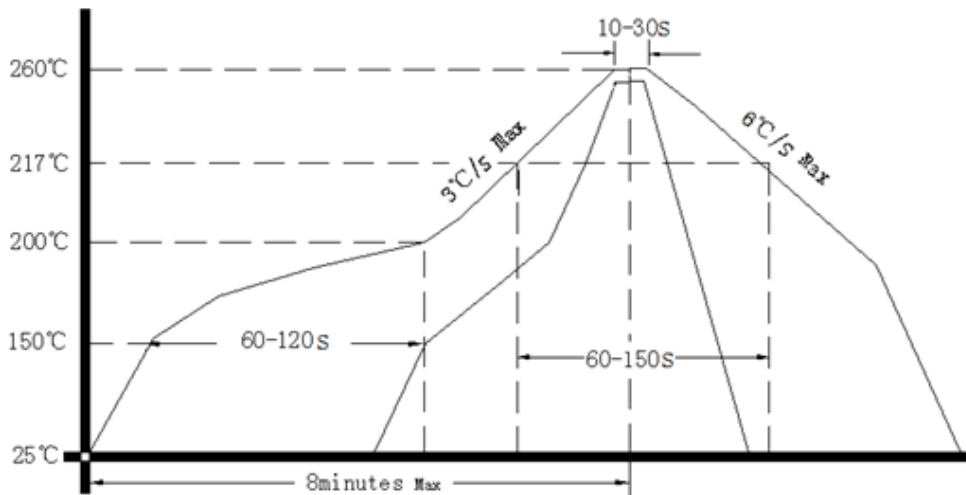

### 5. Package (mm)

