

Travelling Merchant: _____

DATASHEET

Standard: **O21B-E412-19.20MHz**

P/N: _____

Plot			The Label
Drew	Audited	Approved	Stamp, please! Thanks!
Date: 2021.11.30			

Guangdong Dapu Telecom Technology Co.,Ltd

Building 5, No.24, Industrial East Road, Songshanhu Park, Dongguan, Guangdong, P.R. China

TEL: 0086-0769-88010888 FAX: 0086-0769-81800098



Table of amendment

Version	Revision contents	Prepared by	Revised date
1.0	The first issued	<i>Amway</i>	2019.06.05
1.1	The “Mechanical Structure” changed	<i>Amway</i>	2021.11.30



1. Electrical Parameters

MODEL: O21B-E412-19.20MHz						
Item	Description	Parameters			Unit	Test Condition
		Min.	Typ.	Max.		
Output	Frequency	19.20			MHz	
	Output Waveform	Sine wave				
	Level	6			dBm	
	Load	45	50	55	Ω	
	Harmonics Suppression			-25	dBc	
Frequency Stabilities	Frequency Tolerance vs. Operating Temperature Range	-0.01		+0.01	$\times 10^{-6}$	T_A varied from -40°C to 85°C , measurement referenced to frequency observed with $f_{ref}=(f_{max}+f_{min})/2$, $V_{cc}=5.0\text{V}$, $V_c=2.1\text{V}$, $O_{load}=50\Omega$, temperature rise speed less than 2°C per minute.
	Initial Frequency Tolerance	-0.1		+0.1	$\times 10^{-6}$	Measurement referenced to frequency observed with $T_A=25^\circ\text{C}$, $V_{cc}=5.0\text{V}$, $V_c=2.1\text{V}$ and after 15 minutes of operation, within 30 days after ex-works.
	Frequency Tolerance vs. supply voltage	-2		+2	$\times 10^{-9}$	measurement referenced to frequency observed $T_A=25^\circ\text{C}$, V_{cc} varied from 4.75V to 5.25V, $V_c=2.1\text{V}$, $O_{load}=50\Omega$.
	Short-Term Stability Allan variance			0.01	$\times 10^{-9}$	Temperature stability, no EMI/EMC or other interference, test after power for 1hour ref. to 25°C ; 1s .
	Aging Tolerance per day	-0.5		+0.5	$\times 10^{-9}$	V_{cc}, V_c, T_A constant Measurement referenced to frequency observed with
	Aging Tolerance 1 Year	-0.05		+0.05	$\times 10^{-6}$	$T_A=25^\circ\text{C}, V_{cc}=5.0\text{V}, V_c=2.1\text{V}, O_{load}=50\Omega$ and after 30 days of operation.
Power Supply	Supply Voltage	4.75	5.0	5.25	V	
	Current Consumption			350	mA	@ 25°C , $V_{cc}=5\text{V}$
	Current Consumption during warm up			700	mA	$V_{cc}=5\text{V}$
	Warm-up time			3	min	@ 25°C within $\pm 0.05 \times 10^{-6}$ of final frequency with reference after 1 hour on.



Voltage Control Characteristics	Frequency Tuning Range			-0.5	$\times 10^{-6}$	$V_c=0V$. measurement referenced to $V_c=2.1V$.
		-0.1		+0.1	$\times 10^{-6}$	$V_c=2.1V$. measurement referenced to exactly 19.20MHz.
		+0.5			$\times 10^{-6}$	$V_c=4.2V$. measurement referenced to $V_c=2.1V$.
	Linearity			10	%	
	Slope	Positive				
	Input Impedance	100				K Ω
Phase Noise	Phase Noise		-115	-105	dBc/Hz	10Hz
			-130	-120		100Hz
			-140	-135		1KHz
			-150	-145		10KHz
			-150	-145		100KHz
Environmental Conditions	Operable Temperature	-40		+85	$^{\circ}C$	
	Storage Temperature	-60		+90	$^{\circ}C$	
	ESD Level	Human Body Model, class2: 2000V to 4000V; ANSI/ESDA/JEDEC JS-001-2010.				
		Machine Model, class B: 200V to 400V; JEDEC JESD22-A115C.				
	Moisture Sensitivity Level	Not humidity sensitive.				
	Vibration	Test Condition: 0.75mm ;acceleration:10g;10Hz~500Hz, one cycle per 30 min, test 2 hour. (3 times for each 3 directions X , Y , Z), IEC 68-2-06 Test Fc.				
Shock	50g; 11ms; half sine wave (3 times for each 3 directions X, Y, Z), IEC 68-2-27 Test Ea/Severity 50A.					
Full Package Storage	Relative humidity (%)	20% ~70%				
	Temperature ($^{\circ}C$)	-10~35 $^{\circ}C$				



2. Mechanical Structure (mm)

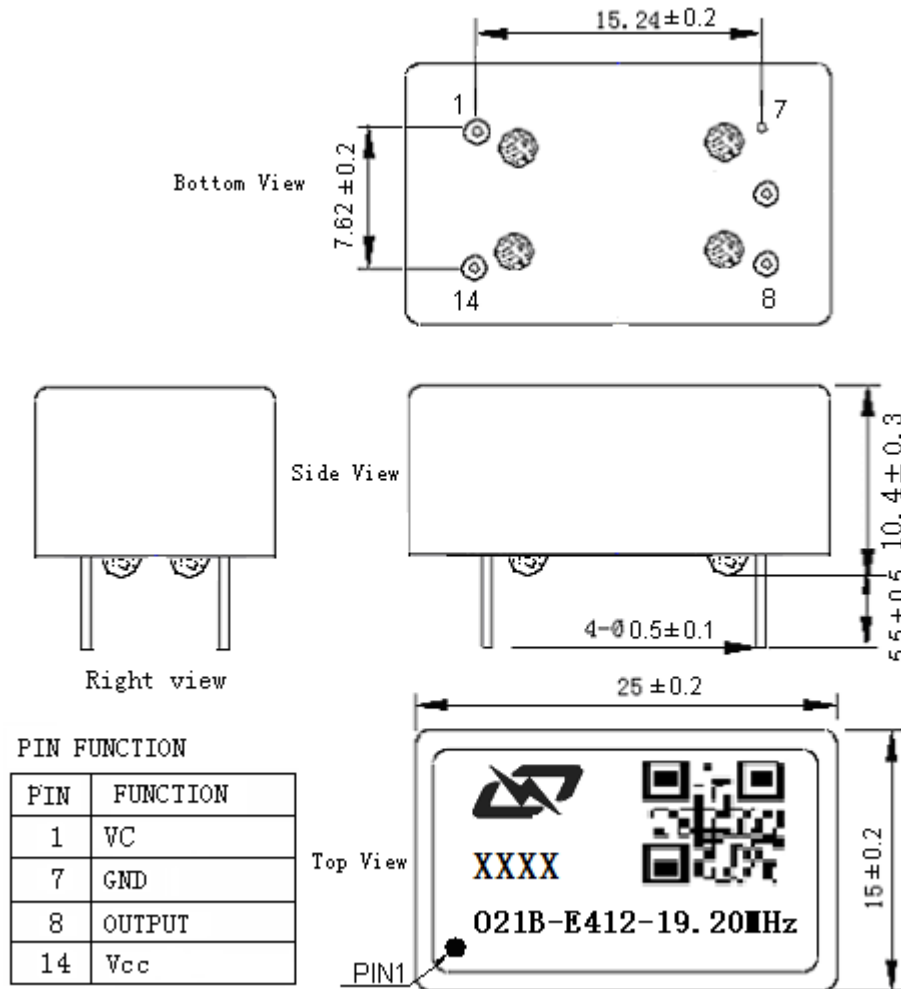

Note1: Tolerance ± 0.2mm without mark

Note2: The first two xx representative: week
After two xx representative: year

Note3: Referential Weight 6.6g



3. Test Circuit

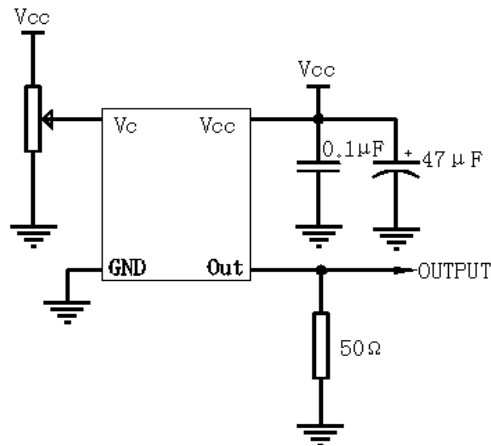

4. Reflow Soldering Curve (RoHS)

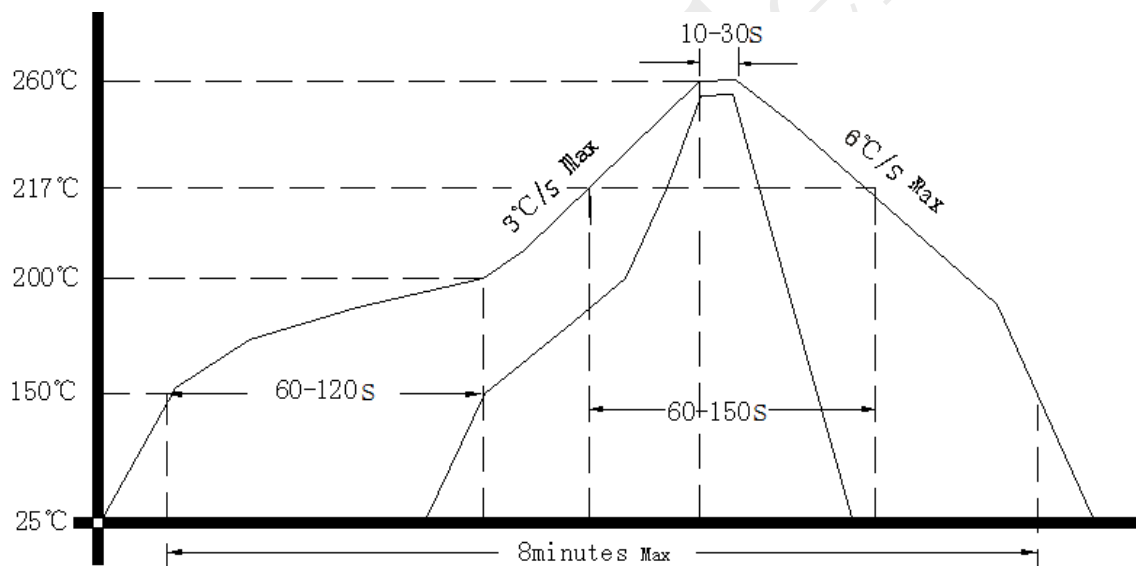

5. Package(mm)

