

Travelling Merchant: \_\_\_\_\_

# DATASHEET

Standard: DP9H32768009

Plot			The Label
Drew	Audited	Approved	Stamp, please! Thanks!
Date: 2022.03.30			

## Guangdong Dapu Telecom Technology Co.,Ltd

Building 5, No.24, Industrial East Road, Songshanhu Park, Dongguan, Guangdong, P.R. China

TEL: 0086-0769-88010888 FAX: 0086-0769-81800098



## 1、Electrical Parameters

MODEL: DP9H32768009							
No.	Parameters	SYM.	Electrical Spec.				Notes
			Min.	Typ.	Max.	Units	
1	Nominal Frequency	FL	32.768			KHz	
2	Frequency Tolerance	$\Delta f/f_0$	-20		+20	ppm	Refer to@25°C
3	Temperature Coefficient	K	-0.034+/-0.006			ppm/(°C) <sup>2</sup>	
4	Turnover Temperature		20	25	30	°C	
5	Load Capacitance	CL		6		pF	
6	Shunt Capacitance	C0	0.9	1.35	2	pF	
7	Motional Capacitance	C1		2.3		fF	
8	Insulation Resistance	IR	500			MΩ	@DC 100V+/-15V
9	Operating Temperature Range	T <sub>opt</sub>	-40		+85	°C	
10	Storage Temperature Range	T <sub>stg</sub>	-55		+125	°C	
11	Aging	$\Delta/f$	-3		+3	ppm	@25°C+/-3°C
12	Drive Level	DL		1		μW	
13	Equivalent Series Resistance	ESR			50	KΩ	Refer to@25°C
14	Quality Factor	Q		75		K	
15	Capacitance Ratio	R		450			



## 2、Mechanical Structure(mm)

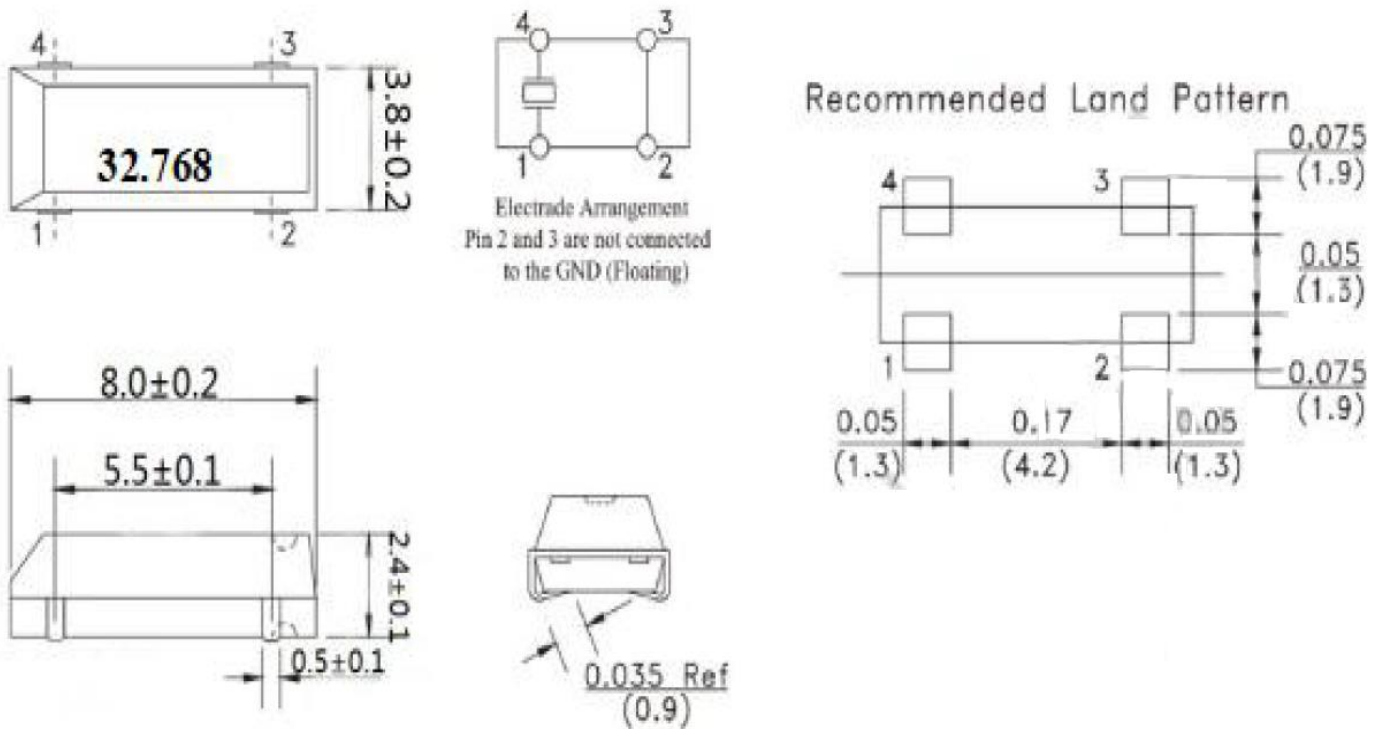

## 3、Reflow Solder

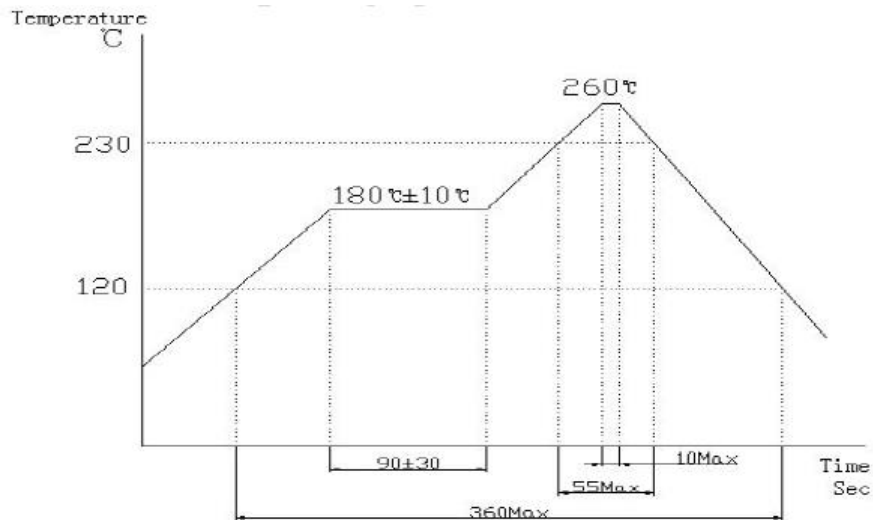



#### 4、 Packing Description

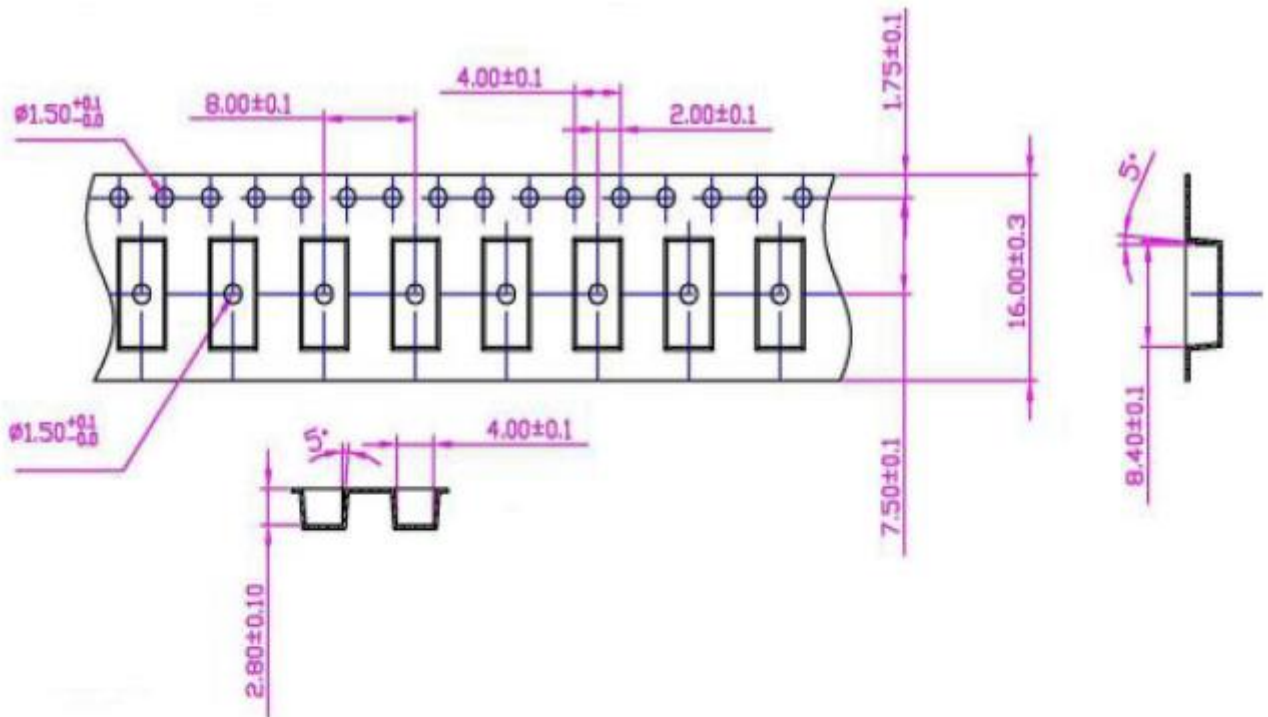

#### Reel Dimensions

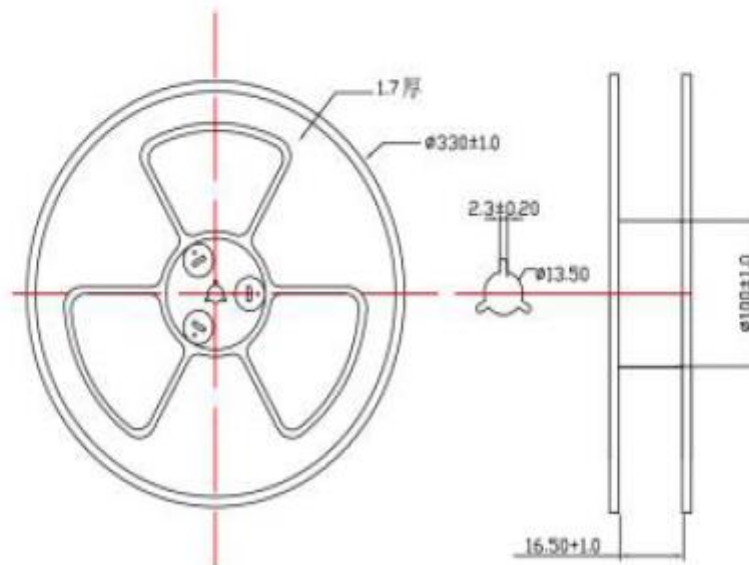

Pieces per reel: 3000/reel