

Travelling Merchant: _____

DATASHEET

Standard: DP6X32768003

Plot			The Label
Drew	Audited	Approved	Stamp, please! Thanks!
Date: 2022.06.06			

Guangdong Dapu Telecom Technology Co.,LTD

Building 5, No.24, Industrial East Road, Songshanhu Park, Dongguan, Guangdong, P.R. China

TEL: 0086-0769-88010888 FAX: 0086-0769-81800098



1、 Electrical Parameters

MODEL: DP6X32768003							
No.	Parameters	SYM.	Electrical Spec.				Notes
			Min.	Typ.	Max.	Units	
1	Nominal Frequency	FL	32.768			KHz	
2	Oscillation Mode	-	Fundamental				
3	Load Capacitance	CL	12.5			pF	
4	Frequency Tolerance	-	-20	~	+20	$\times 10^{-6}$	at 25°C± 3°C
5	Q Factor		40000				
6	Turnover Temperature	-	20	25	30	$\times 10^{-6}$	
7	Parabolic Coefficient				-0.04	$\times 10^{-6}/^{\circ}\text{C}^2$	
8	Drive Level	DL	0.8	1	1.2	μW	
9	Motional Resistance	Rr	-	-	50	K Ω	
10	Shunt Capacitance C0	C0	-	1.25	-	pF	
11	Insulation Resistance	-	500	-	-	M Ω	at DC 100V
12	Operating Temperature	-	-40	~	+85	$^{\circ}\text{C}$	
13	Storage Temperature Range	-	-40	~	+85	$^{\circ}\text{C}$	
14	Moisture Sensitivity Level	Level: 1					

2、 Mechanical Structure(mm)

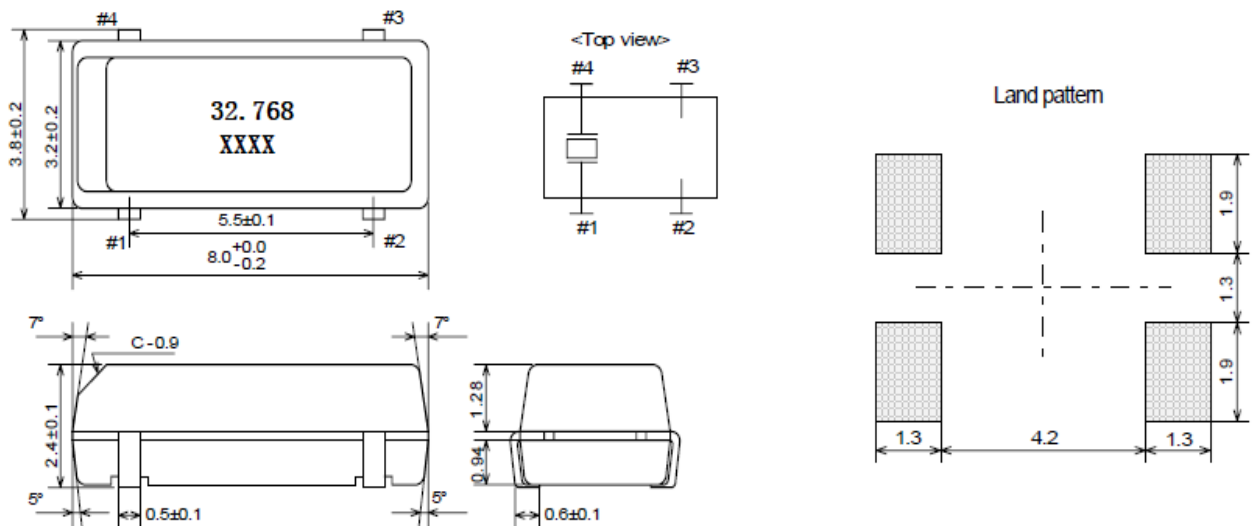

Note1: Tolerance $\pm 0.2\text{mm}$ without mark

Note2: The first two xx representative: year
After two xx representative: week