



## DSO3001-32A-LD3D-156M2500 All-silicon Oscillator

### Key Features

- All-silicon without quartz and MEMS
- Total frequency stability :  $\pm 50$  ppm
- Differential output: 156.25 MHz
- Operating temperature :  $-40^{\circ}\text{C}\sim 85^{\circ}\text{C}$
- Power supply: 3.3V
- Output: LVDS
- Package: 3225
- Low jitter: 350 fs Typ RMS (12 kHz – 20 MHz bandwidth)
- Built-in LDO and power filter circuit
- RoHS Compliant

### Application

- Automotive electronics
- Intelligent terminal
- Ethernet
- Consumer electronics
- Communication equipment

### Block Diagram

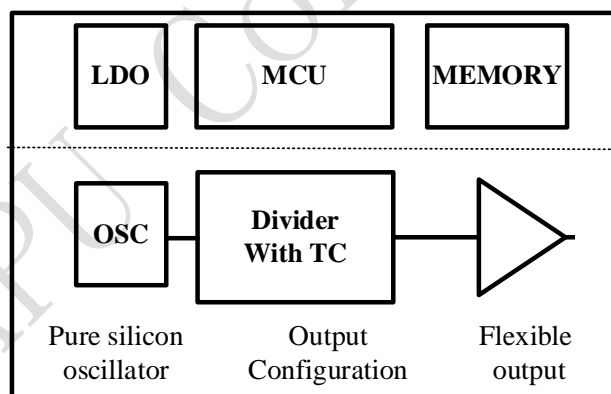

### Overview

DSO3001-32A-LD3D-156M2500 adopts unique frequency synthesis and sensor technology, which can output 156.25 MHz without quartz and MEMS devices. The product can keep low jitter and frequency stability in the whole working range, and has high reliability in harsh environment and strong vibration.



### Revision History

Version	Change Contents	Prepared by	Revised Date
V1.0.0	First Issued		

DAPU Confidential



## Index

<b>1</b>	<b>OVERVIEW</b> .....	<b>4</b>
<b>2</b>	<b>BLOCK DIAGRAM</b> .....	<b>4</b>
<b>3</b>	<b>FEATURES</b> .....	<b>4</b>
<b>4</b>	<b>PIN DEFINITION</b> .....	<b>5</b>
<b>5</b>	<b>ELECTRICAL SPECIFICATIONS</b> .....	<b>5</b>
<b>6</b>	<b>ENVIRONMENTAL CONDITIONS</b> .....	<b>7</b>
<b>7</b>	<b>DIMENSION AND PACKAG</b> .....	<b>7</b>
	7.1 DIMENSION (3225) .....	8
	7.2 PCB .....	8
	7.3 MARKING .....	9
<b>8</b>	<b>ORDERING GUIDE</b> .....	<b>9</b>
<b>9</b>	<b>APPENDIX</b> .....	<b>10</b>
	RECOMMENDED OUTPUT TERMINATION .....	10
	LVDS .....	10



# 1 Overview

DSO3001-32A-LD3D-156M2500 is a clock free oscillator without quartz and MEMS devices. It is a high reliable clock oscillator which can still work normally under harsh environment and strong vibration. The chips can generate a frequency of 156.25MHz, and maintain low jitter and frequency stability throughout the operation range.



Thanks to the built-in temperature and stress sensors, the chip can adapt to the harsh working environment. The built-in LDO and filter circuit greatly enhance the power supply noise suppression ability of the chip. Flexible clock frequency configuration and output format configuration provide maximum convenience for customer product design.

# 2 Block Diagram

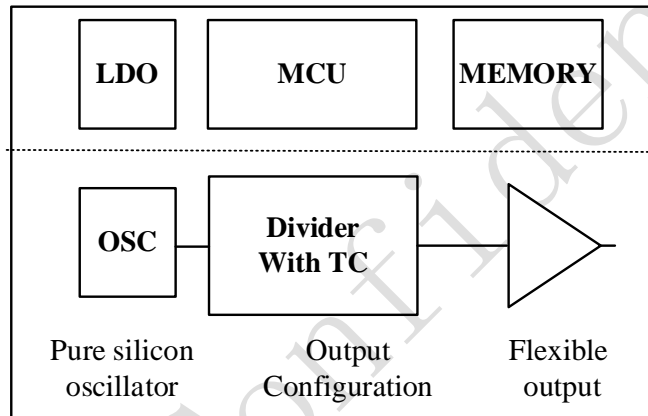

# 3 Features

- All-silicon without quartz and MEMS
- Total frequency stability:  $\pm 50$  ppm
- Differential output: 156.25 MHz
- Operating temperature:  $-40^{\circ}\text{C} \sim 85^{\circ}\text{C}$
- Power supply: 3.3V
- Output: LVDS
- Package: 3225
- Low jitter: 350 fs Typ RMS (12 kHz – 20 MHz bandwidth)
- Built-in LDO and power filter circuit
- RoHS Compliant



## 4 Pin Definition

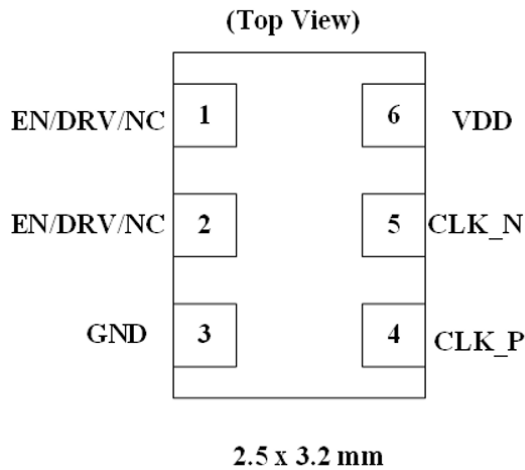

PIN	Description
1	Optional function EN = Output Enable, active high DRV = Output Driver Enable, active high NC = Not Connect
2	Optional function (refer to PIN1)
3	GND
4	CLK_P
5	CLK_N
6	VDD

## 5 Electrical Specifications

Table 5.1 Absolute Maximum Ratings<sup>1</sup>

Parameter	Symbol	Rating	Unit
Operating Temperature	T <sub>A</sub>	-40 to 85	°C
Storage Temperature	T <sub>S</sub>	-55 to 105	°C
Supply Voltage	V <sub>DD</sub>	-0.5 to 3.8	V
Input Voltage	V <sub>IN</sub>	-0.5 to V <sub>DD</sub> + 0.3	V
ESD HBM (JESD22-A114)	HBM	4.0	kV
Solder Temperature <sup>2</sup>	T <sub>PEAK</sub>	260	°C
Solder Time at T <sub>PEAK</sub> <sup>2</sup>	T <sub>P</sub>	20 - 40	sec

**Notes:**

1. Stresses beyond those listed in this table may cause permanent damage to the device. Functional operation specification compliance is not implied at these conditions. Exposure to maximum rating conditions for extended periods may affect device reliability.

2. The device is compliant with JEDEC J-STD-020.

Table 5.2 Recommended Operating Conditions

Parameter	Symbol	Min	Typ	Max	Unit	Test Condition/Comment
Supply Voltage	V <sub>DD</sub>	1.71	1.8	1.89	V	V <sub>DD</sub> = 1.8 V
		2.375	2.5	2.625	V	V <sub>DD</sub> = 2.5 V
		3.135	3.3	3.47	V	V <sub>DD</sub> = 3.3 V
Supply Current (F <sub>CLK</sub> = 50 MHz)	I <sub>DD</sub>		40	50	mA	Tristate Hi-Z (EN = 0, output disabled)
			1	2	mA	Ready State



						(DRV = 0, standby mode)
			70	80	mA	LVPECL (DC-Coupled)
			60	70	mA	LVPECL (AC-Coupled)
			45	55	mA	LVDS
			60	70	mA	HCSL
			60	70	mA	CML
			40	55	mA	CMOS
			50	60	mA	Dual CMOS
Operating Temperature	TA	-40		85	°C	

Table5.3 Input Electrical Specifications

Parameter	Symbol	Min	Typ	Max	Unit	Test Condition/Comment
Output Enable (EN) <sup>1</sup>	V <sub>IH</sub>	0.7×V <sub>DD</sub>			V	
	V <sub>IL</sub>			0.3×V <sub>DD</sub>	V	
	T <sub>D</sub>			3	μs	Output Disable Time, F <sub>CLK</sub> >10 MHz
	T <sub>E</sub>			20	μs	Output Enable Time, F <sub>CLK</sub> >10 MHz
Output Enable (DRV) <sup>1</sup>	V <sub>IH</sub> '	0.7×V <sub>DD</sub>			V	
	V <sub>IL</sub> '			0.3×V <sub>DD</sub>	V	
	T <sub>D</sub> '			3	μs	Output Disable Time. Within 40us, the current drops to less than 1.5mA F <sub>CLK</sub> >10 MHz
	T <sub>E</sub> '			400	μs	Output Enable Time, F <sub>CLK</sub> >10 MHz

Notes:

1.EN/DRV includes a 50 kΩ pull-up to V<sub>DD</sub> for EN active high. Includes a 50 kΩ pull-down to GND for EN/DRV active low. NC (No Connect) pins include a 50 kΩ pull-down to GND.

Table 5.4 Output Electrical Specifications

Parameter	Symbol	Min	Typ	Max	Unit	Test Condition/Comment
Frequency Range	F <sub>CLK</sub>		156.25		MHz	LVDS
Total Stability <sup>1</sup>	F <sub>STAB</sub>	-50		50	ppm	Frequency stability
Rise/Fall Time (20% to 80% V <sub>PP</sub> )	T <sub>R</sub> /T <sub>F</sub>			350	ps	LVDS
Powerup Time	t <sub>OSC</sub>			4	ms	Time from 0.9 × V <sub>DD</sub> until output frequency (F <sub>CLK</sub> ) within spec
Duty Cycle	DC	45		55	%	
LVDS Output Option <sup>2</sup> (DC-Coupled)	V <sub>OC</sub>	1.125	1.20	1.275	V	Mid-level (2.5 V, 3.3 V V <sub>DD</sub> )
		0.795	0.85	0.905	V	Mid-level (1.8 V V <sub>DD</sub> )
	V <sub>O</sub>	0.5	0.82	0.96	V <sub>PP</sub>	Swing (diff <sup>3</sup> )
	V <sub>OL</sub>	0	5	10	mV	Output voltage low

Notes:



1. Total Stability, includes temperature stability, initial accuracy, load pulling,  $V_{DD}$  variation, and aging for 10 years at 40°C.
2.  $R_{term} = 100 \Omega$  (differential)
3. “diff” means differential signal

Table 5.5 Clock Output Phase Jitter and PSRR

Parameter	Symbol	Min	Typ	Max	Unit	Test Condition/Comment
Phase Jitter (RMS, 12 kHz - 20 MHz) <sup>1,2</sup> $F_{CLK} \geq 10$ MHz	$\phi_J$		350	750	fs	Differential Formats
			350		fs	CMOS, Dual CMOS
Phase Jitter (RMS, 50 kHz - 20 MHz) $F_{CLK} \geq 156.25$ MHz	$\phi_J$		150	250	fs	Differential Formats
			100		fs	CMOS, Dual CMOS
Spurs Induced by External Power Supply Noise, 50 mV <sub>pp</sub> Ripple. LVDS 156.25 MHz Output $V_{DD} = 1.8$ V	PSRR		-76		dBc	100 kHz sine wave
			-75		dBc	200 kHz sine wave
			-75		dBc	500 kHz sine wave
			-75		dBc	1 MHz sine wave
Spurs Induced by External Power Supply Noise, 50 mV <sub>pp</sub> Ripple. LVDS 156.25 MHz Output $V_{DD} = 2.5$ or 3.3 V	PSRR		-83		dBc	100 kHz sine wave
			-83		dBc	200 kHz sine wave
			-83		dBc	500 kHz sine wave
			-82		dBc	1 MHz sine wave

Notes:

1. Applies to output frequency: 50, 100, 156.25, 212.5, 350 MHz.
2. Guaranteed by characterization. Jitter inclusive of any spurs.

## 6 Environmental Conditions

Table 6.1. Environmental Conditions

Package	Symbol	Parameter	Test Condition	Value	Unit
	MSL	Moisture Sensitivity Level	1		
3225 6-pin DFN	$\Theta_{JA}$	Thermal Resistance Junction to Ambient	Still Air	108	°C/W
	$\Theta_{JB}$	Thermal Resistance Junction to Board	Still Air	84	°C/W
	$T_J$	Max Junction Temperature	Still Air	125	°C

## 7 Dimension and Packag



## 7.1 Dimension (3225)

**Table 7.1. Package Diagram Dimensions (mm)**

Dimension	Min	Nom	Max
A		2.5 BSC	
B		3.2 BSC	
C	0.8	0.85	0.9
C1	0	0.035	0.05
C2		0.203 REF	
D		1.175 BSC	
E	0.6	0.65	0.7
F	0.65	0.7	0.75
G	0.45	0.5	0.55

H		0.8 REF	
aaa		0.1	
bbb		0.1	
ccc		0.08	
ddd		0.07	
eee		0.05	

**Figure 7.1. DSO3001 (3225) Outline Diagram**

**Notes:**

1. The dimensions in parentheses are reference.
2. All dimensions in millimeters (mm).
3. Dimensioning and Tolerancing per ANSI Y14.5M-1994.

## 7.2 PCB

The figure below illustrates the PCB land pattern for the DSO3001. The table below lists the values for the dimensions shown in the illustration.

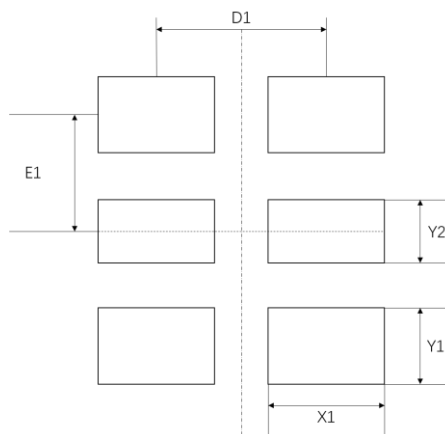

**Figure 7.3. PCB Land Pattern**

**Table 7.3. PCB Land Pattern Dimensions (mm)**

Dimension	3225(mm)





X1	0.7
Y1	0.65
Y2	0.5
D1	1.6
E1	1.05

### 7.3 Marking

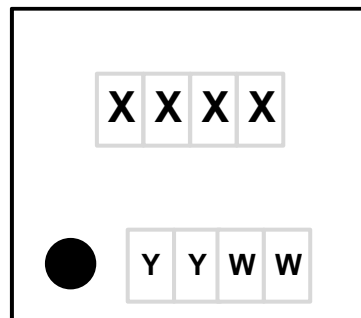

Figure 7.4 DSO3001 Top Mark

Table 7.4 Top Mark Description

Line	Print	Description
1	XXXX	LOGO
2	YYWW	DATE

## 8 Ordering Guide

The naming rules and definitions of DSO3001 are as follows:

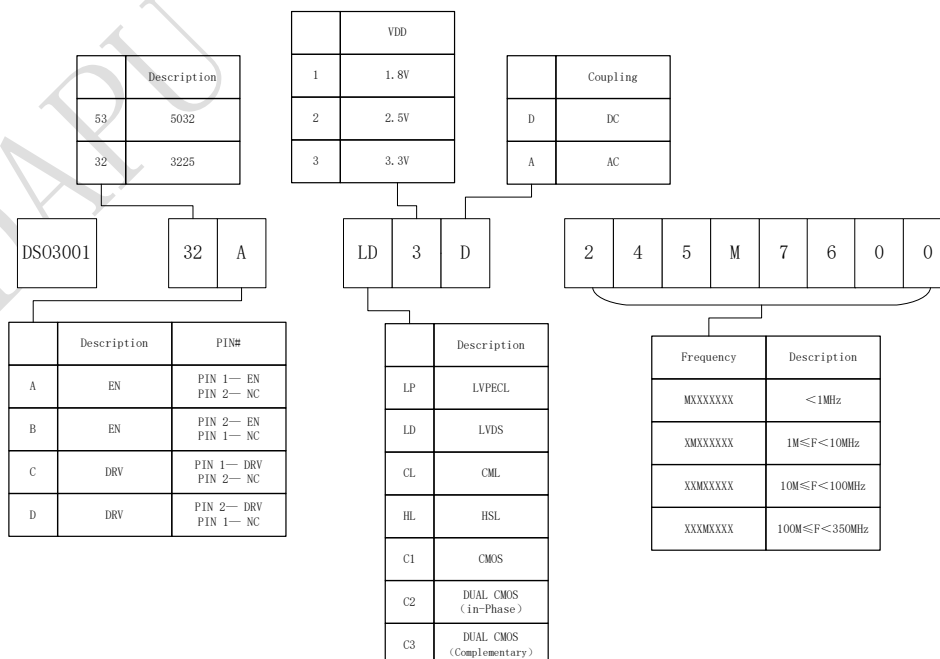



Notes:

1. DSO3001-32A-LD3D-245M7600 means a silicon crystal with 3225 package, 1 pin defined as EN, input voltage 3.3V, output 245.76M DC-coupled LVDS signal.
2. Recommended Signal Formats and Voltage Combinations

Signal Format	VDD	Coupling
LVPECL	2.5V/3.3V	DC/AC
LVDS	1.8V/2.5V/3.3V	DC
CML	1.8V/2.5V/3.3V	AC
HCSL(50 $\Omega$ termination)	1.8V/2.5V/3.3V	DC
HCSL(42.5 $\Omega$ termination)	1.8V/2.5V/3.3V	DC
CMOS/Dual CMOS	1.8V/2.5V/3.3V	DC

## 9 Appendix

### Recommended Output Termination

LVDS

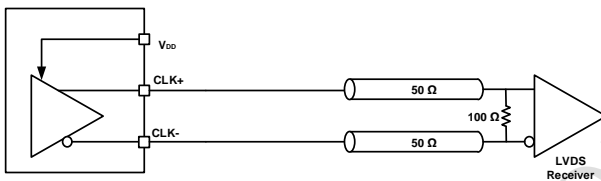

DC-Coupled LVDS

Figure 4. LVDS Output Terminations