

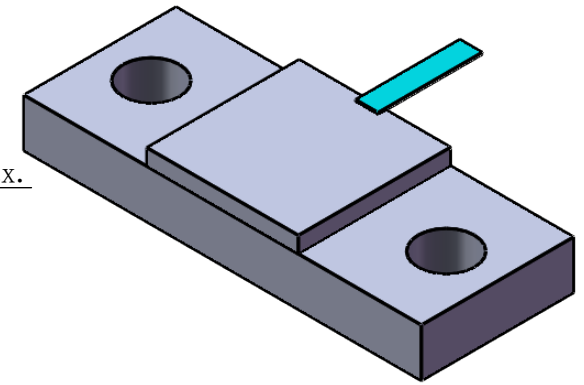

RoHS COMPLIANT

REVISIONS				
REV.	ECN NO.	DESCRIPTION	DATE	REVISOR
1			2022/2/10	ZC.Wu

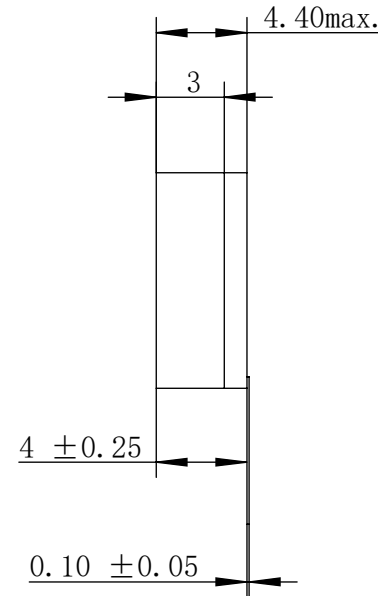
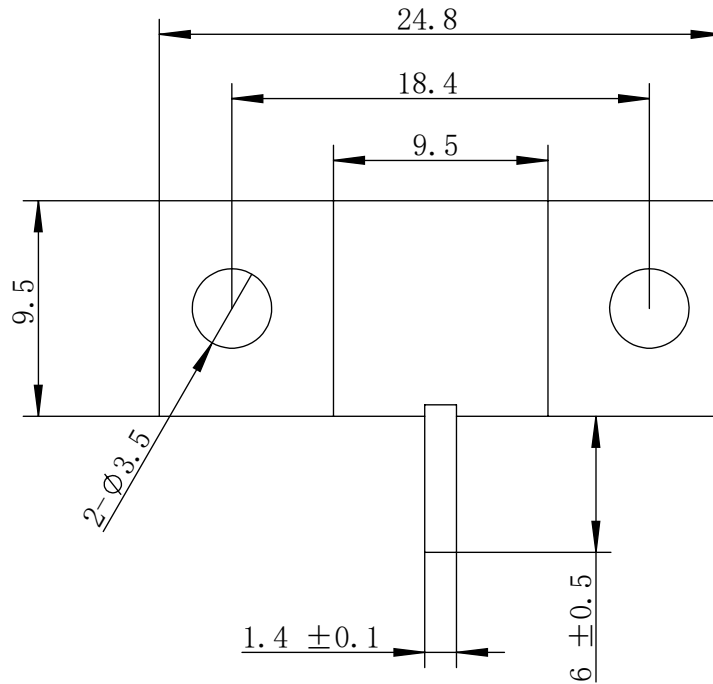

NOTES:

- SUBSTRATE: ALUMINIUM NITRIDE
- FINISH: METALIZATION, SILVER OVER NICKEL
- RESISTANCE: $50 \pm 5\%$ OHM
- OPERATING TEMP.: $-55^{\circ} + 155^{\circ}C$
- RETURN LOSS: 21dB MIN
FREQUENCY DC-3.0GHz
- POWER: 250W
- SUPPLIER: YLT (RFR50N-250TBAH2525B)

PART NAME: 250W 负载片	Designed: ZC. Wu	
DRAWING NO. : TER-00015	Checked:	
DESCRIPTION: Termination	Approval:	TOLERANCES ON
	The first angle projection: 	DECIMALS
	Sheet 1 of 1	ANGLES
	Scale: 1:1	.x ±0.10
	Unit: mm	.xx ±0.05
		.xxx ±0.02
		±0.5°