

5mm SMD ISOLATOR

RF component

Datasheet No.: DP-B-0093(00)
Date: 2021.06.27

Customer:

Celte

Product Name:

DP-IL0520A2593-J1

DP-IL0520B2593-J1

Customer P/N:



GuangdongDapuTelecomTechnologyCo.,Ltd Bldg13-16,.N.Ind.Zone,SSLIndustry
http://www.dptel.com

Park,DongguanCity,Guangdong

Province,PRChina

TEL:0086-0769-88010888

FAX:0086-0769-81800098

| Approved | Checked | Designer |
|----------|---------|----------|
| Patrick | Nina | Bill |

5mm SMD ISOLATOR

RF component

Datasheet No.: DP-B-0093(00)
 Date: 2021.06.27

MECHANICAL SPECIFICATION

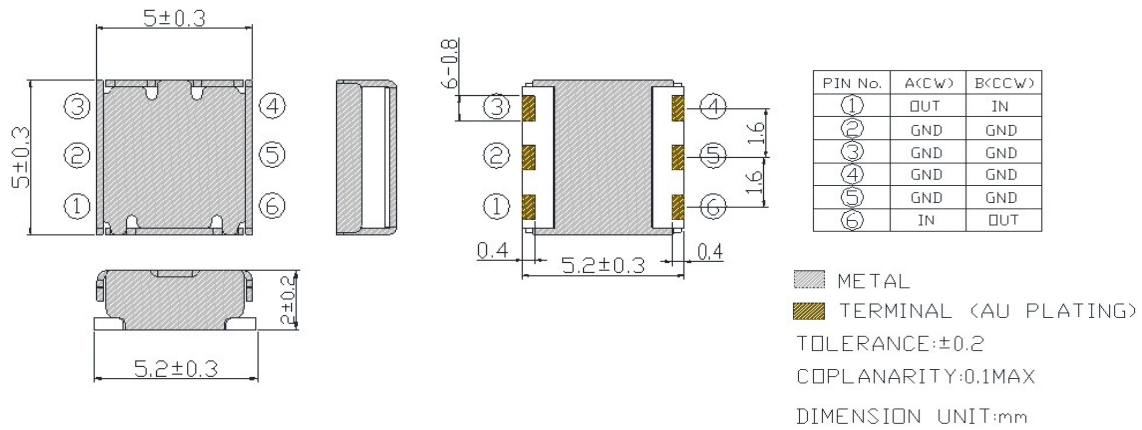

MARKING

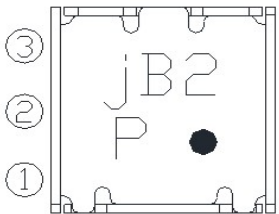
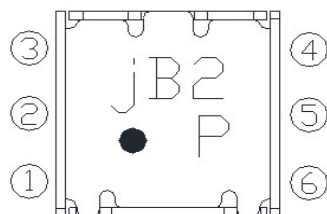
| DP-IL0520A2593-J1 | DP-IL0520B2593-J1 | ①/⑥ : Out/In Port ②~⑤: Ground j: Year/ Month of Production B: Week of Production 2: Day of Production P: Frequency ● : Input Port |
|---|---|---|
| Clockwise | CounterClockwise | |
|  |  | |

| Year/Month Code | | | | | | | | | | | |
|----------------------|-------|------|----------------------|-------|------|----------------------|-------|------|--------------|-------|------|
| Year | Month | Code | Year | Month | Code | Year | Month | Code | Year | Month | Code |
| 2020 2024 2028 | 1 | a | 2021 2025 2029 | 1 | n | 2022 2026 2030 | 1 | A | 2023 2027 | 1 | N |
| | 2 | b | | 2 | p | | 2 | B | | 2 | P |
| | 3 | c | | 3 | q | | 3 | C | | 3 | Q |
| | 4 | d | | 4 | r | | 4 | D | | 4 | R |
| | 5 | e | | 5 | s | | 5 | E | | 5 | S |
| | 6 | f | | 6 | t | | 6 | F | | 6 | T |
| | 7 | g | | 7 | u | | 7 | G | | 7 | U |
| | 8 | h | | 8 | v | | 8 | H | | 8 | V |
| | 9 | j | | 9 | w | | 9 | J | | 9 | W |
| | 10 | k | | 10 | x | | 10 | K | | 10 | X |
| | 11 | l | | 11 | y | | 11 | L | | 11 | Y |
| | 12 | m | | 12 | z | | 12 | M | | 12 | Z |

| Week Code | |
|-----------|------|
| Week | Code |
| 1 | A |
| 2 | B |
| 3 | C |
| 4 | D |
| 5 | E |

| Day Code | |
|-----------|------|
| Day | Code |
| Monday | 1 |
| Tuesday | 2 |
| Wednesday | 3 |
| Thursday | 4 |
| Friday | 5 |
| Saturday | 6 |
| Sunday | 7 |

5mm SMD ISOLATOR

RF component

Datasheet No.: DP-B-0093(00)
 Date: 2021.06.27

TEMPERATURE RANGE

Operating temperature range : -40~+85°C

Storage temperature range:-40~+125°C

ELECTRICAL CHARACTERISTICS

| Parameter | Unit | Frequency (MHz) | | DP Spec | | | |
|--------------------------------|------|-----------------|--|---------|------|------|------|
| | | | | Min. | Typ. | Max. | |
| Frequency range | MHz | 2496 | | 2690 | 2496 | | 2690 |
| Insertion Loss | dB | - | | - | | | 0.80 |
| Isolation | dB | - | | - | 13 | | |
| Return Loss | dB | - | | - | 13 | | |
| Power Handing (Average) | W | | | | | | 3 |
| Power Handing (Peak) | W | | | | | | 10 |
| Reflection power | W | | | | | | 2 |
| Characteristic Impedance (ohm) | Ω | | | | | 50 | |
| Case Style | - | | | | | SMD | |

NOTES

- 1.Recommend to keep 30mm above when mounted with other magnetic products.
- 2.ROHS compliance.
- 3.Isolator's characteristics are guaranteed at conditions listed at above table and it's operating temperature range.

5mm SMD ISOLATOR

RF component

Datasheet No.: DP-B-0093(00)
 Date: 2021.06.27

RECOMMENDED LAND PATTERN

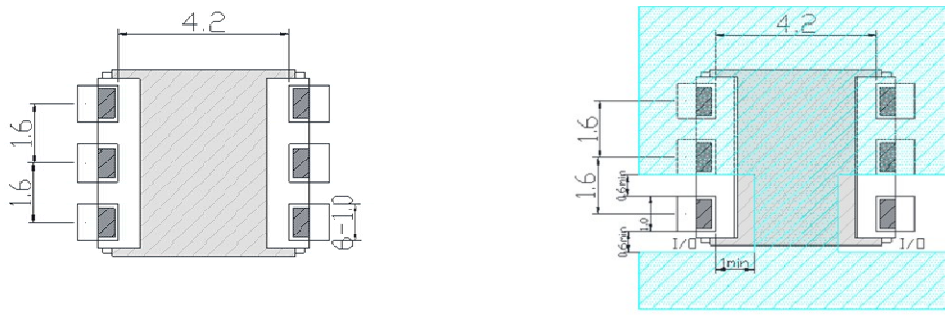

DIMENSION UNIT:mm

RECOMMENDED REFLOW PROFILE

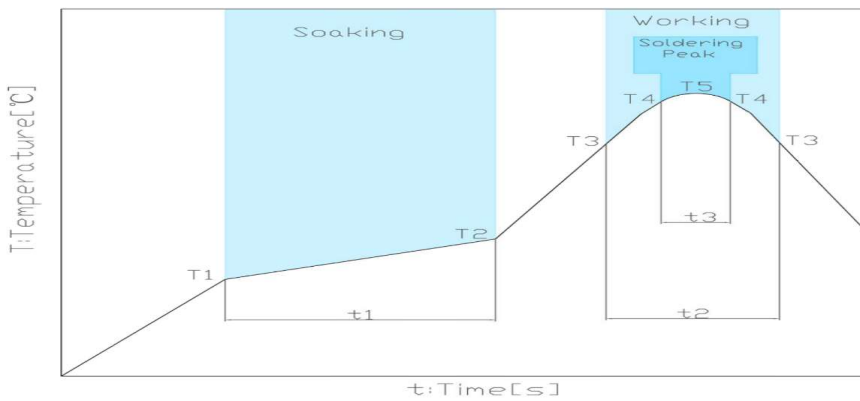

| Soaking | | | Working | | Soldering Peak | | |
|---------|-------|------------|---------|-----------|----------------|------------|------------|
| Temp. | Temp. | Time | Temp. | Time | Temp. | Time | Temp. |
| T1 | T2 | t1 | T3 | t2 | T4 | t3 | T5 |
| 150°C | 180°C | 60 to 120s | 230°C | 30 to 60s | 250°C | within 10s | 260°C max. |

5mm SMD ISOLATOR

RF component

Datasheet No.: DP-B-0093(00)
 Date: 2021.06.27

PACKING STYLE

REEL DIMENSIONS

Reel side \longrightarrow Pulling side

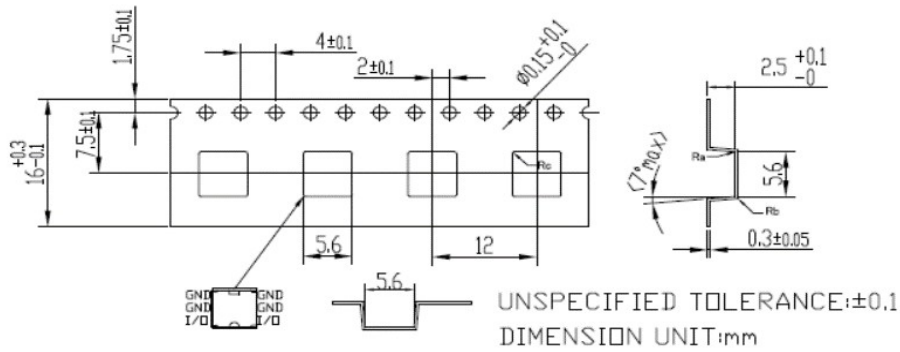

TAPE DIMENSIONS

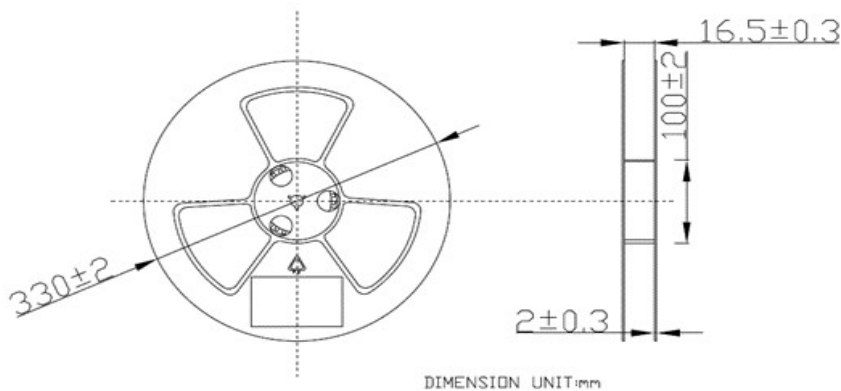

PACKAGE QUANTITY

1000 PCS/REEL

5mm SMD ISOLATOR

RF component

Datasheet No.: DP-B-0093(00)
 Date: 2021.06.27

Revision Records

| Rev. | Date | PIC | Change item | Reasons for change |
|------|------------|------|-----------------|--------------------|
| 1 | 2021.06.27 | Nina | New regulations | |
| 2 | | | | |
| 3 | | | | |
| 4 | | | | |
| 5 | | | | |
| 6 | | | | |
| 7 | | | | |
| 8 | | | | |