

Travelling Merchant: _____

DATASHEET

Standard: **O22B-X448-100.00MHz-B**

P/N: _____

Plot			The Label
Drew	Audited	Approved	Stamp, please! Thanks!
Date: 2021.06.29			

Guangdong Dapu Telecom Technology Co.,Ltd

Building 5, No.24, Industrial East Road, Songshanhu Park, Dongguan, Guangdong, P.R. China

TEL: 0086-0769-88010888 FAX: 0086-0769-81800098



Table of amendment

Version	Revision contents	Prepared by	Revised date
1.0	The first issued	<i>Amway</i>	2021.04.30
1.1	The “Mechanical Structure” changed	<i>Amway</i>	2021.06.29



1. Electrical Parameters

MODEL: O22B-X448-100.00MHZ-B						
Item	Description	Parameters			Unit	Test Condition
		Min.	Typ.	Max.		
Output	Frequency	100.00			MHz	
	Waveform	Sine wave				
	Level	7			dBm	
	Load	50			Ω	
	Harmonics Suppression			-30	dBc	
	Spurious Suppression			-70	dBc	
Frequency Stabilities	Frequency Tolerance vs. Operating Temperature Range	-0.1		+0.1	$\times 10^{-6}$	T_A varied from -40°C to 80°C , measurement referenced to frequency observed with $f_{\text{ref}}=(f_{\text{max}}+f_{\text{min}})/2$, $V_{\text{cc}}=12.0\text{V}$, $O_{\text{load}}=50\Omega$, temperature variable speed less than 2°C per minute.
	Initial Frequency Tolerance	-0.2		+0.2	$\times 10^{-6}$	Measurement referenced to frequency observed with $T_A=25^{\circ}\text{C}$, $V_{\text{cc}}=12.0\text{V}$, $V_c=4.5\text{V}$ and after 15 minutes of operation, within 30 days after ex-works.
	Frequency Tolerance vs. supply voltage	-0.01		+0.01	$\times 10^{-6}$	measurement referenced to frequency observed $T_A=25^{\circ}\text{C}$, V_{cc} varied from 11.4V to 12.6V, $V_c=4.5\text{V}$, $O_{\text{load}}=50\Omega$.
	Frequency Tolerance vs. Load	-0.01		+0.01	$\times 10^{-6}$	5% Load Change Measurement referenced to frequency observed with $T_A=25^{\circ}\text{C}$, $V_{\text{cc}}=12\text{V}$, $V_c=4.5\text{V}$, $O_{\text{load}}=50\Omega$.
	G-Sensitivity			1	$\times 10^{-9}/\text{g}$	$T_A=25^{\circ}\text{C}$, $V_{\text{cc}}=12.0\text{V}$
	Aging Tolerance per day	-3		+3	$\times 10^{-9}$	V_{cc}, V_c, T_A constant Measurement referenced to frequency observed with $T_A=25^{\circ}\text{C}$,
	Aging Tolerance 1 Year	-0.3		+0.3	$\times 10^{-6}$	$V_{\text{cc}}=12.0\text{V}$, $V_c=4.5\text{V}$, $O_{\text{load}}=50\Omega$ and after 30 days of operation.
Power Supply	Supply Voltage	11.4	12.0	12.6	V	
	Reference Voltage	8.5	9.0	9.5	V	
	Current Consumption			150	mA	@ 25°C
	Current Consumption during warm up			400	mA	@ 25°C



Voltage Control Characteristics	Frequency Tuning Range			-1.5	$\times 10^{-6}$	$V_c=0V$. measurement referenced to $V_c=4.5V$.
		-0.2		+0.2	$\times 10^{-6}$	$V_c=4.5V$. measurement referenced to exactly 100.00MHz.
		+1.5			$\times 10^{-6}$	$V_c=9.0V$. measurement referenced to $V_c=4.5V$.
	Linearity			10	%	
	Slope	Positive				
	Input Impedance	100				K Ω
Phase Noise	Phase Noise @25°C			-90	dBc/Hz	10Hz
				-120		100Hz
				-150		1KHz
				-160		10KHz
				-165		100KHz
Environmental Conditions	Operable Temperature	-40		+80	°C	
	Storage Temperature	-55		+105	°C	
	ESD Level	Human Body Model, class2: 2000V to 4000V; ANSI/ESDA/JEDEC JS-001-2010.				
		Machine Model, class B: 200V to 400V; JEDEC JESD22-A115C.				
	Moisture Sensitivity Level	Not humidity sensitive.				
	Vibration	Test Condition: 0.75mm ;acceleration:10g;10Hz~500Hz, one cycle per 30 min, test 2 hour. (3 times for each 3 directions X ,Y , Z), IEC 68-2-06 Test Fc.				
Shock	50g; 11ms; half sine wave (3 times for each 3 directions X ,Y, Z),IEC 68-2-27 Test Ea/Severity 50A.					



2. Mechanical Structure (mm)

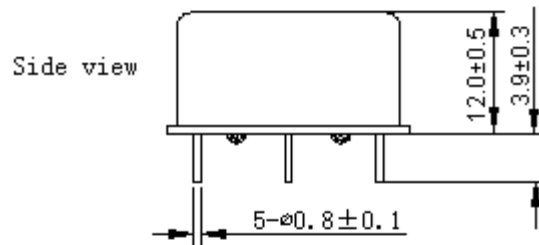
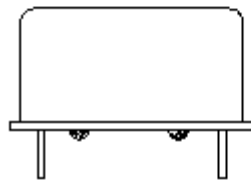
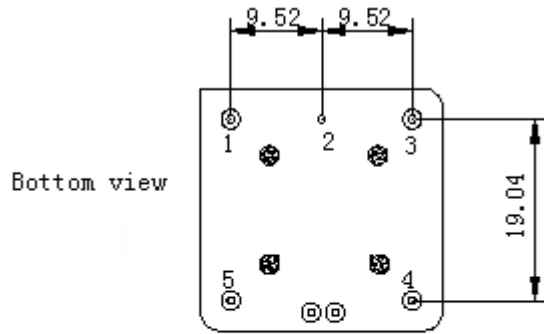

PIN FUNCTION

PIN	NOTATION	FUNCTION
1	OUTPUT	RF Output
2	GND	GND
3	VC	Control Voltage
4	VREF	9V
5	VCC	Supply Voltage

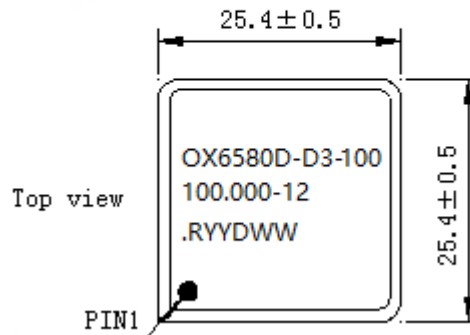

Note1: Tolerance $\pm 0.2\text{mm}$ without mark

Note2: The two YY representative: year

After two WW representative: week

Note3: Referential Weight 13.6g



3. Test Circuit

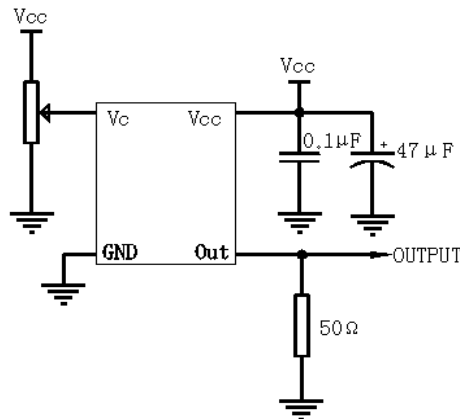

4. Reflow Soldering Curve (RoHS)

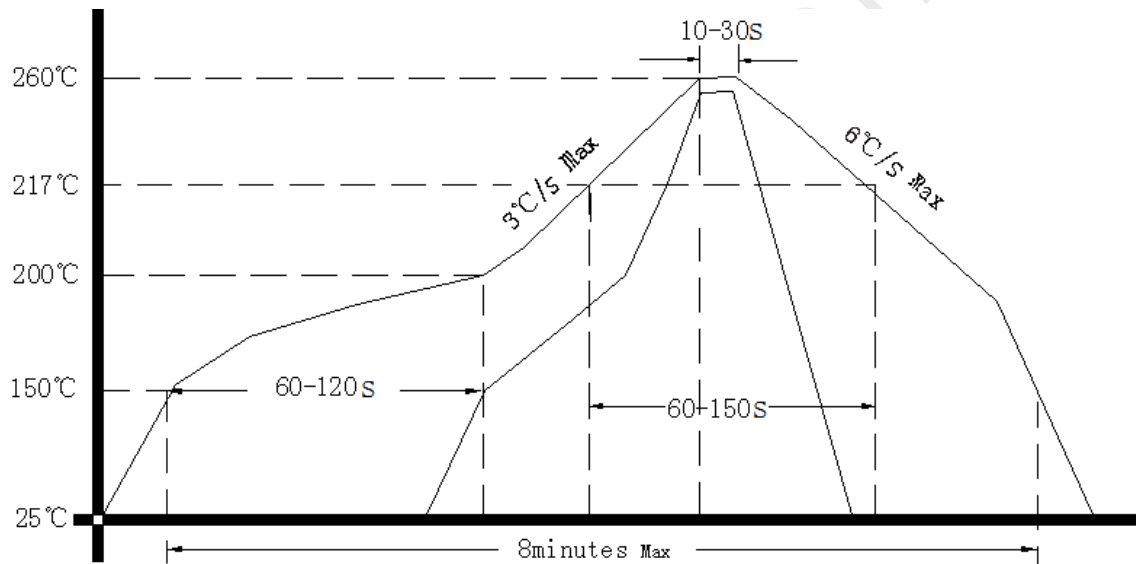

5. Package(mm)

