

Travelling Merchant: \_\_\_\_\_

# DATASHEET

Standard:                   **T21-S589-10.00MHz**                  

Plot			The Label
Drew	Audited	Approved	Stamp, please! Thanks!
Date: 2021.05.07			

## Guangdong Dapu Telecom Technology Co.,Ltd

Building 5, No.24, Industrial East Road, Songshanhu Park, Dongguan, Guangdong, P.R. China

TEL: 0086-0769-88010888    FAX: 0086-0769-81800098



## 1、 Electrical Parameters

MODEL: T21-S589-10.00MHz								
No	Parameters		SYM.	Electrical Spec.				Notes
				Min.	Typ.	Max.	Units	
1	Nominal Frequency		-	10.00			MHz	
2	Supply Voltage		-	2.66	2.8	2.94	V	
3	Current consumption		-	-	-	1.5	mA	
4	Output Level		-	0.8	-	-	Vp-p	
5	Harmonics		-	-	-	-5	dBc	
6	Output Waveform		-	Clipped Sine wave			-	
7	Standard Output Load		-	10KΩ//10pF			-	
8	Frequency Stability	vs.Tolerance	-	-1.5	-	+1.5	$\times 10^{-6}$	@25±3℃ Sixty minutes after reflow
9		vs. Temperature	-	-0.5	-	+0.5	$\times 10^{-6}$	TA= -40~+85° C Ref. to Frequency (TA=+25° C)
10		vs. Load	-	-0.2	-	+0.2	$\times 10^{-6}$	
11		vs. Supply Voltage	-	-0.2	-	+0.2	$\times 10^{-6}$	
12	Operating Temperature Range		-	-40	~	+85	℃	
13	Storage Temperature		-	-40	~	+85	℃	
14	Start Up Time		-	-	-	2.0	ms	@90% of final Vout level
15	Aging		-	-1.0	-	+1.0	$\times 10^{-6}$	PER YEAR ( AT 25 °C ± 5°C)
16	Phase Noise	@ 1KHz Offset	-	-	-	-135	dBc/Hz	
17	ESD Level		Human Body Model,class2: 2000V to 4000V; ANSI/ESDA/JEDEC JS-001-2010.					
			Machine Model, class B: 200V to 400V; JEDEC JESD22-A115C.					
18	Moisture Sensitivity Level		Level 2.					
19	Vibration		Test Condition: 0.75mm ;acceleration:10g;10Hz~2000Hz, one cycle per 30 min, test 2 hour. (3 times for each 3 directions X , Y , Z ) .IEC 68-2-06 Test Fc.					
20	Shock		100g; 6ms; half sine wave (3 times for each 3 directions X , Y , Z ),IEC 68-2-27 Test Ea/Severity 50A.					



## 2、Mechanical Structure(mm)

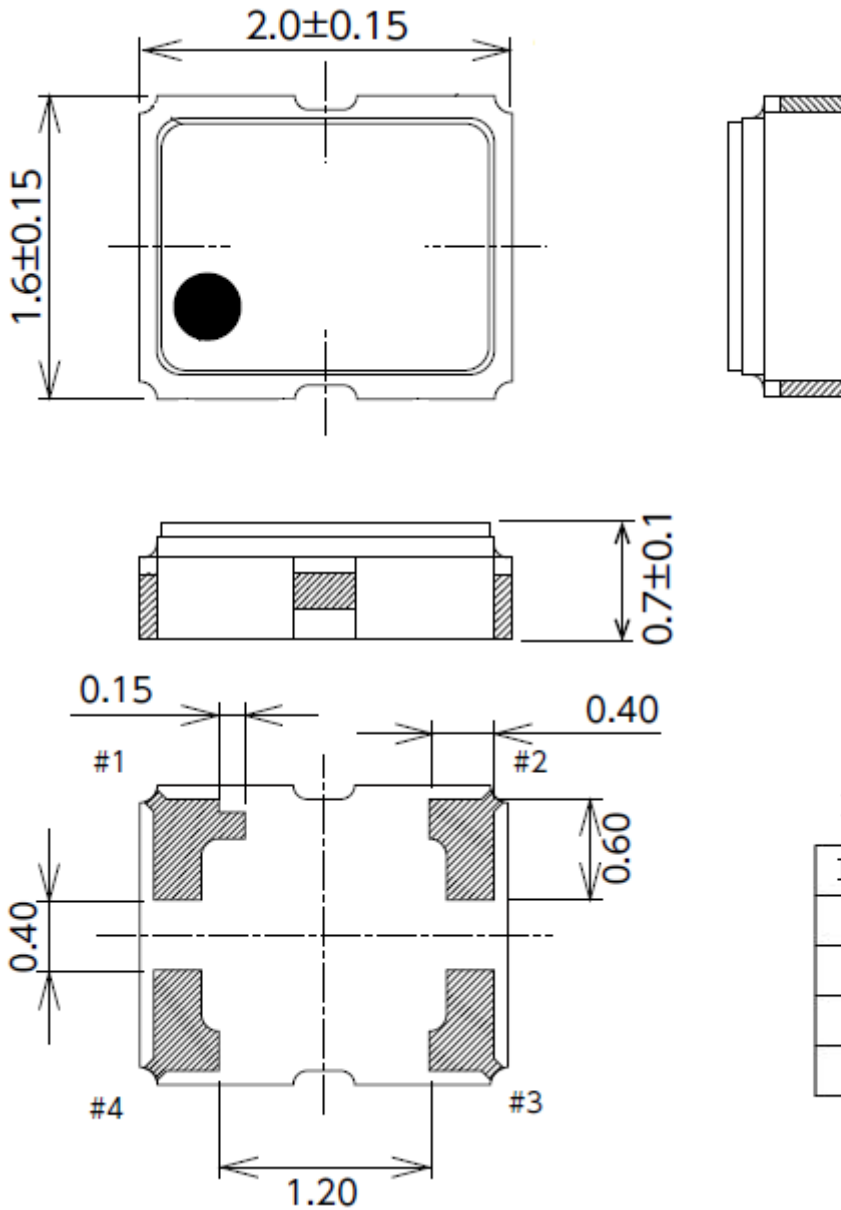

PIN FUNCTION

PIN	FUNCTION
1	NC / GND
2	GND
3	OUTPUT
4	VCC

Note1: Tolerance  $\pm 0.2$ mm



### 3. Test Circuit

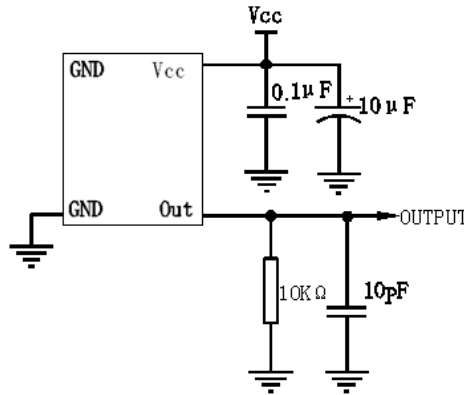

### 4. Reflow Soldering Curve (RoHS)

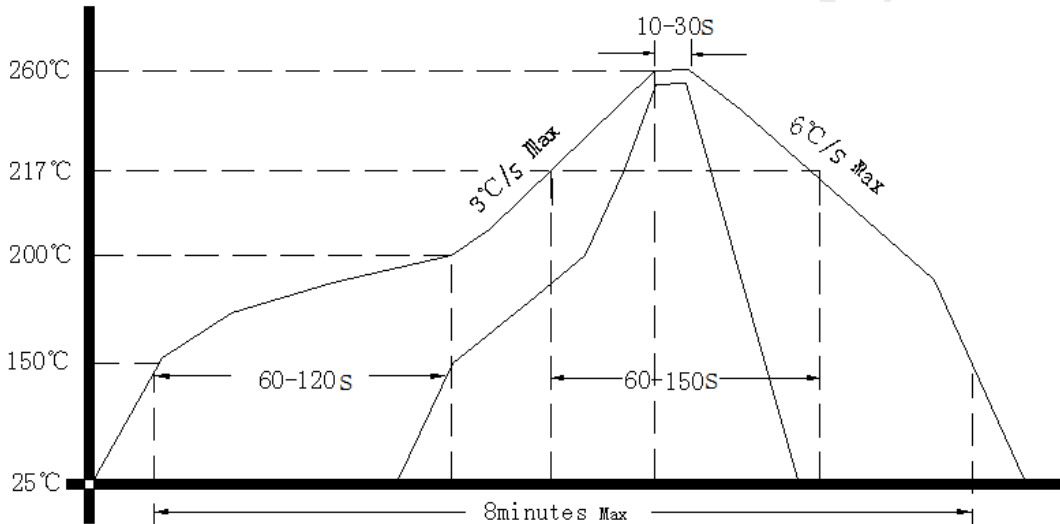

### 5. Package: Tape & Reel (mm)

