

Customer Code: _____

DATASHEET

DAPU P/N: T12A-F419-80.00MHz-A

Customer P/N: _____

DAPU			Customer Approval
Drew	Audited	Approved	Stamp, please! Thanks!
Date: 2021.05.27			

Guangdong Dapu Telecom Technology Co.,Ltd

Building 5, No.24, Industrial East Road, Songshanhu Park, Dongguan, Guangdong, P.R. China

TEL: 0086-0769-88010888 FAX: 0086-0769-81800098



1. Electrical Parameters

MODEL: T12A-F419-80.00MHz-A						
Item	Description	Parameters			Unit	Test Condition
		Min.	Typ.	Max.		
Output	Frequency	80.00			MHz	
	Output Waveform	Sine Wave				
	Level	+4	+7		dBm	$V_{cc} = 3.3V, O_{load}=50\Omega$.
	Harmonics Suppression		-30	-25	dBc	$V_{cc} = 3.3V, O_{load}=50\Omega$.
	Spurious Suppression		-80		dBc	
	Load	50			Ω	
Frequency Stabilities	Frequency Tolerance vs. Operating Temperature Range	-0.5		+0.5	$\times 10^{-6}$	T_A varied from $-40^\circ C$ to $85^\circ C$, measurement referenced to frequency observed with $f_{ref}=(f_{max}+f_{min})/2$, $V_{cc}=3.3V$, temperature variable speed less than $2^\circ C$ per minute.
	Initial Frequency Tolerance	-1.0		+1.0	$\times 10^{-6}$	Measurement referenced to frequency observed with $T_A=25^\circ C$, $V_{cc}=3.3V$, and after 15 minutes of operation, within 30 days after ex-works.
	Frequency Tolerance vs. Supply Voltage	-0.1		+0.1	$\times 10^{-6}$	measurement referenced to frequency observed $T_A=25^\circ C$, V_{cc} varied from 3.13V to 3.47V, and $O_{load}=50\Omega$.
	Frequency Tolerance vs. Load	-0.1		+0.1	$\times 10^{-6}$	5% load change measurement referenced to frequency observed with $T_A=25^\circ C$, $V_{cc}=3.3V$, and $O_{load}=50\Omega$.
	Aging Tolerance First Year	-1		+1	$\times 10^{-6}$	V_{cc}, T_A constant measurement referenced to frequency observed with $T_A=25^\circ C$, $V_{cc}=3.3V$, and after 30 days of operation.
Power Supply	Current Consumption			40	mA	@ $25^\circ C$, $V_{cc}=3.3V, O_{load}=50\Omega$.
	Supply Voltage	3.13	3.3	3.47	V	



Jitter	Phase Jitter		0.4		ps	12KHz to 20MHz
Phase Noise	Phase Noise		-80		dBc/Hz	10Hz
			-110			100Hz
			-140			1KHz
			-155			10KHz
			-160			100KHz
Environmental Conditions	Operable Temperature	-40		+85	°C	
	Storage Temperature	-55		+105	°C	
	ESD Level	Human Body Model, class2: 2000V to 4000V; ANSI/ESDA/JEDEC JS-001-2010.				
		Machine Model, class B: 200V to 400V; JEDEC JESD22-A115C.				
	Moisture Sensitivity Level	Not humidity sensitive.				
	Vibration	Test Condition: 0.75mm ;acceleration:10g;10Hz~2000Hz, one cycle per 30 min, test 2 hour. (3 times for each 3 directions X , Y , Z) .IEC 68-2-06 Test Fc.				
Shock	100g; 6ms; half sine wave (3 times for each 3 directions X ,Y, Z),IEC 68-2-27 Test Ea/Severity 50A.					
Full Package Storage	Relative humidity (%)	20%~70%				
	Temperature (°C)	-10~35°C				



2. Mechanical Structure(mm)

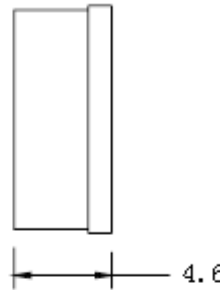
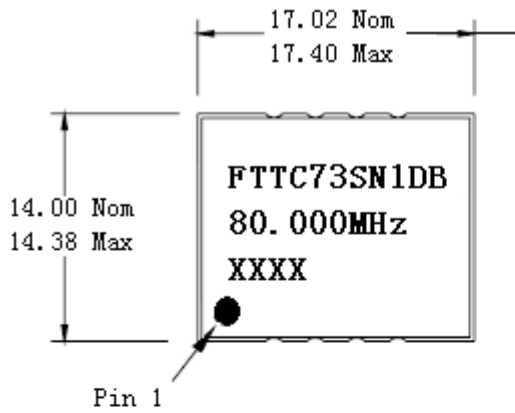

PIN CONNECTIONS

1	Supply Voltage
2	N/C
3	Gnd
4	Gnd
5	Output
6	N/C
7	N/C
8	N/C

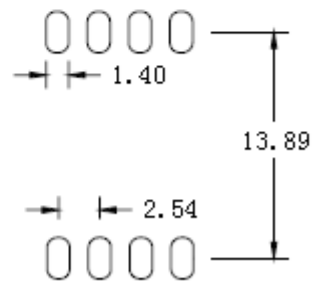
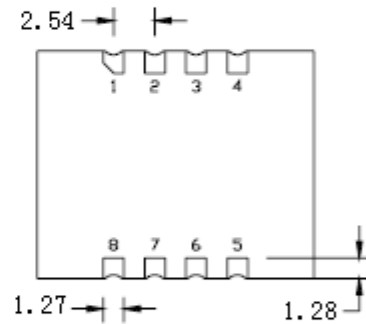

Recommended land pattern based on IPC-7351

Note1: Tolerance ± 0.20 mm without mark

Note2: The first two xx representative: year
After two xx representative: week



3. Test circuit

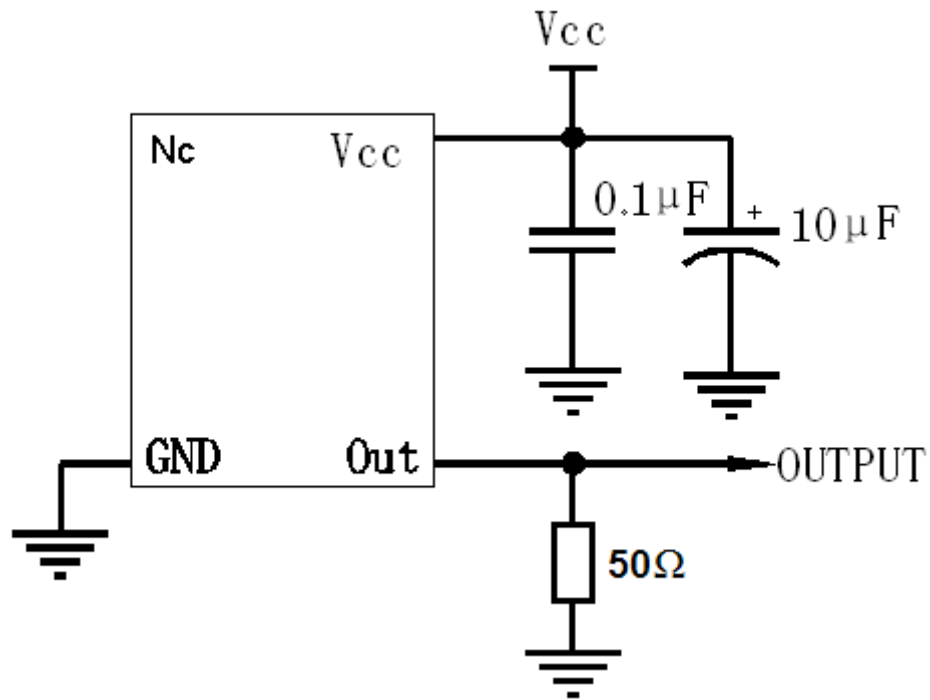

4. Reflow Soldering Curve (RoHS)

