

DP3000E PTP Grandmaster

DP3000E is a high-performance Grand Master device designed to provide precise frequency, phase and time-of-day synchronization information for LTE/LTE-A networks and other applications. The device is IEEE 1588-2008 (1588V2) standard compliant and uses GNSS timing satellite signal as a primary time reference.

Using DP's advanced PTP IC and adaptive timing calculations. Deploying a centralized Grand Master with full on-path support to deliver high precision synchronization involves higher cost.

DP3000E is highly field-scalable to 512 PTP slaves in unicast mode at 16 packets per second.

Feature

- Redundant hardware: inputs/outputs clock and power
- Hardware-based packet processing

- User-configurable PTP profiles with IPV4 and IPV6 support
- Supports ITU PTP profiles(G.8265.1,G.8275.1,and G.8275.2)
- Supports Synchronous Ethernet (G.8262)
- Concurrent reception of GPS/QZSS GLONASS Beidou
- Management through CLI and DPsync.
- CES
- PON
- Femto cells and small cells
- Gateway clock for industrial IoT applications

Benefits

- Low cost of ownership
- Highly scalable PTP grandmaster supports 512 PTP clients at full 16 messages per second rate
- Support PTP elements in the network
- Simple, easy manageability
- Gateway clock

Applications

- Wireless Ethernet backhaul
- 3G ,4G/LTE,and 5G

DP3000E PTP Grandmaster

Specifications

IEEE 1588-2008 PTP

- IEEE1588-2008 (PTP) Grand master.
- Built-in clocks holdover algorithm, meet the requirements of the wireless system.
- PTP output client capacity: max 512 clients.
- Maximum slaves: 512,16pkt/s.
- G.8261, G.8265.1/2 ,G.8275.1 compliant.
- PTP: L2/L3 unicast or multicast PTP

Synchronous Ethernet :

- Conforms to relevant sections of ITU-T G.8262

GNSS

- GPS /Beidou/GLONASS

Frequency Accuracy

- Tracking to GNSS: PRS/PRC quality
Holdover ($\pm 5^{\circ}\text{C}$):Rubidium $<1 \times 10^{-11}/\text{day}$
OCXO $<2 \times 10^{-10}/\text{day}$

Time Accuracy

- Tracking to GNSS: <30 ns when locked to GNSS,
PRTC-compliant
Holdover ($\pm 5^{\circ}\text{C}$):
Rubidium: $1.5\mu\text{sec}$ over 1 days
OCXO: $1.5\mu\text{sec}$ over 1 day

Mechanical :

- Dimensions:44mm(H) x 220 mm(W) x 146 mm(D)
- Weight: 2.2kg

Environmental Specifications

- Operating temperature: 0°C to $+60^{\circ}\text{C}$
- Storage temperature: -40°C to $+85^{\circ}\text{C}$

- Humidity:30% to 80% with condensation

Power Requirement

- Supply:-48VDC or 96~265VAC
- Power consumption: 20W typical

LEDs

- RUN,GNSS,ALARM and PTP SATUS

DP3000E PTP Grandmaster

Interface

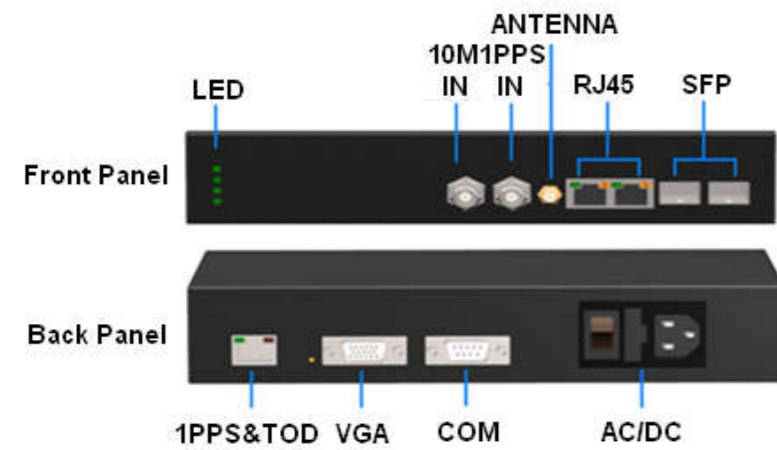

- COM port for configuration
- VGA port for TOD, 10MHz, 1PPS and other frequency outputs/inputs, support extensions

Typical block

- GNSS receiving antenna
- Two-way Ethernet port;
- Two-way SFP port
- GNSS receiving antenna(SMA)
- 2X IEEE1588 PTP 100Base-TX & 1000Base-T with SyncE(RJ45)
- 2X IEEE1588 PTP 1000Base-X with SyncE (SFP)
- 10MHz Frequency standard output(BNC)
- 1PPS standard output(BNC)
- 1PPS + TOD output(RJ45)

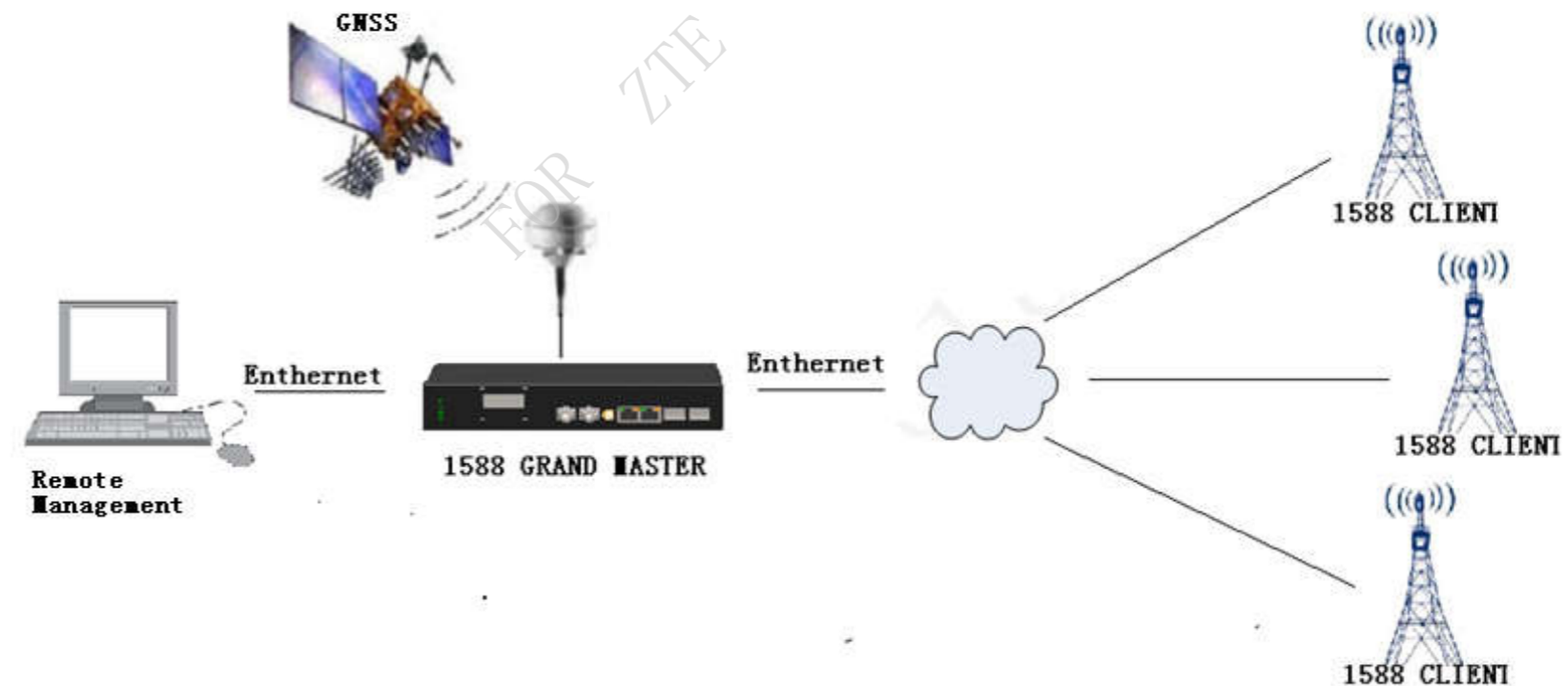

Typical wireless backhaul application utilizing the DP3000E Grandmaster Clock with fully redundant, carrier-class architecture to provide precise timing and frequency for remote base stations over a packet-based Ethernet network infrastructure.