

Travelling Merchant: _____

DATASHEET

Standard: **T21-A573-26.00MHz-B**

P/N: _____

Plot			The Label
Drew	Audited	Approved	Stamp, please! Thanks!
Date: 2021.05.19			

Guangdong Dapu Telecom Technology Co.,Ltd

Building 5, No.24, Industrial East Road, Songshanhu Park, Dongguan, Guangdong, P.R. China

TEL: 0086-0769-88010888 FAX: 0086-0769-81800098



Table of amendment

Version	Revision contents	Prepared by	Revised date
1.0	The first issued	<i>Amway</i>	2021.05.19

DAPIU Confidential



1. Electrical Parameters

MODEL: T21-A573-26.00MHz-B						
Item	Description	Parameters			Unit	Test Condition
		Min.	Typ.	Max.		
Output	Frequency	26.00			MHz	
	Output Waveform	Clipped Sine Wave				
	Start up time			0.8	ms	Output amplitude $\geq 350\text{mV}$ Within $\pm 20 \times 10^{-6}$
				1.5	ms	90% of final output amplitude Within $\pm 2 \times 10^{-6}$
				2.5	ms	95% of final output amplitude Within $\pm 0.1 \times 10^{-6}$
				5.0	ms	100% of final output amplitude Within $\pm 0.05 \times 10^{-6}$
	Vp-p	0.7		1.2	V	
	Harmonics			-20	dBc	2nd
				-10	dBc	3rd
				-60	dBc	34th, 36th, >69th
			-18	dBc	Other	
Load	10K Ω //10pF					
Frequency Stabilities	Frequency Tolerance	-2		+2	$\times 10^{-6}$	@25 $^{\circ}\text{C}$
	vs. Temperature Range	-1.5		+1.5	$\times 10^{-6}$	T _A varied from -40 $^{\circ}\text{C}$ to 85 $^{\circ}\text{C}$, measurement referenced to frequency observed with T _A =25 $^{\circ}\text{C}$, V _{cc} =1.8V, V _c =0.9V, O _{load} =10K Ω //10pF, temperature variable speed less than 2 $^{\circ}\text{C}$ per minute.
	Frequency Tolerance vs. Supply Voltage	-0.2		+0.2	$\times 10^{-6}$	measurement referenced to frequency observed T _A =25 $^{\circ}\text{C}$, V _{cc} varied from 1.70V to 1.90V, and O _{load} =10K Ω //10pF



Frequency Stabilities	Frequency Tolerance vs. Load	-0.2		+0.2	$\times 10^{-6}$	10% load change measurement referenced to frequency observed with $T_A=25^\circ\text{C}$, $V_{cc}=1.8\text{V}$, and $O_{Load}=10\text{K}\Omega//10\text{pF}$.
	Aging Tolerance Per Day	-0.02		+0.02	$\times 10^{-6}$	$T_A=25^\circ\text{C}$, $V_{cc}=1.8\text{V}$, and after 1h of operation.
	Aging Tolerance 1 Year	-1		+1	$\times 10^{-6}$	
Power Supply	Operating Current			2	mA	@ 25°C , $V_{cc}=1.8\text{V}$
	Supply Voltage	1.70	1.80	1.90	V	
Phase Noise	Phase Noise@ 25°C			-108	dBc/Hz	100Hz
				-130	dBc/Hz	1KHz
				-145	dBc/Hz	10KHz
				-148	dBc/Hz	100KHz
				-148	dBc/Hz	1MHz
Voltage Control Characteristics	Frequency Tuning Range			-8	$\times 10^{-6}$	$V_c=0.05\text{V}$. measurement referenced to $V_c=0.9\text{V}$
		+7			$\times 10^{-6}$	$V_c=1.5\text{V}$. measurement referenced to $V_c=0.9\text{V}$
		+10.5			$\times 10^{-6}$	$V_c=1.8\text{V}$. measurement referenced to $V_c=0.9\text{V}$
	Tuning linearity deviation	-20		+20	%	Relative to mean df/dV_{con}
	Tuning sensitivity			16	$\times 10^{-6}/\text{V}$	
	Input Impedance	100			$\text{K}\Omega$	
Environmental Conditions	Operable Temperature	-30		+85	$^\circ\text{C}$	
	Storage Temperature	-40		+90	$^\circ\text{C}$	
	ESD Level	Human Body Model,class2: 2000V to 4000V; ANSI/ESDA/JEDEC JS-001-2010.				
		Machine Model, class B: 200V to 400V; JEDEC JESD22-A115C.				
	Moisture Sensitivity Level	Level 2.				
	Vibration	Test Condition: 0.75mm ;acceleration:10g;10Hz~2000Hz, one cycle per 30 min, test 2 hour. (3 times for each 3 directions X , Y , Z) .IEC 68-2-06 Test Fc.				
	Shock	100g; 6ms; half sine wave (3 times for each 3 directions X , Y , Z),IEC 68-2-27 Test Ea/Severity 50A.				
Full Package Storage	Relative humidity (%)	20%~70%				
	Temperature ($^\circ\text{C}$)	-10~35 $^\circ\text{C}$				



2. Mechanical Structure(mm)

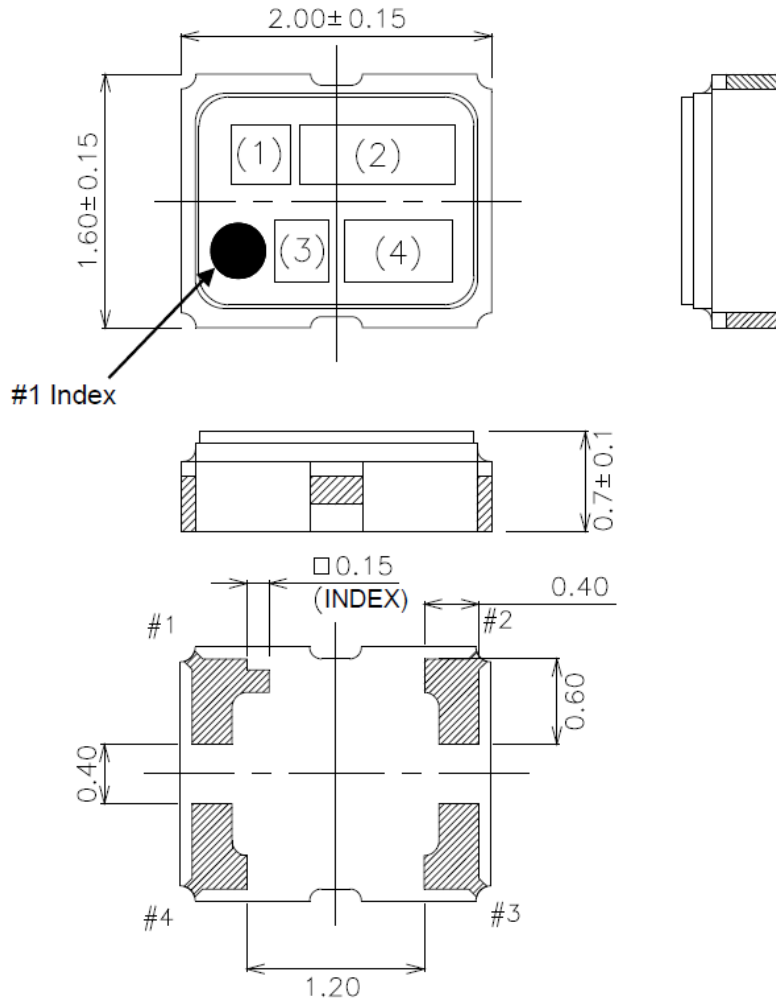

Pin Connections

Pin No.	Connection
#1	V_{CONT}
#2	GND
#3	Output
#4	V_{CC}

Marking

(1) Model code	AN
(2) Frequency	26.0 (MHz, 3digits)
(3) Logo	D
(4) Date code	Year (1digit) +Week (2digits)
	e.g.2017/1/1 → 701

unit: mm

Dimensional Tolerance: ± 0.15

(Unless otherwise noted)

DAPU



3. Test Circuit

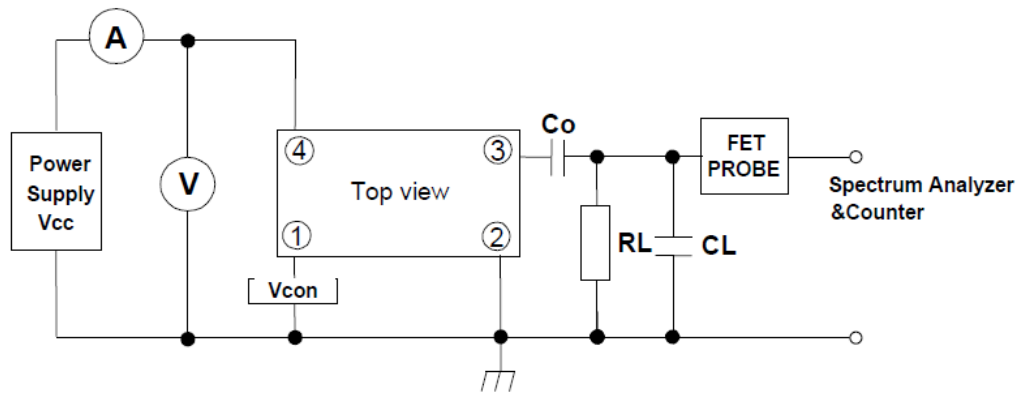

4. Reflow Soldering Curve (RoHS)

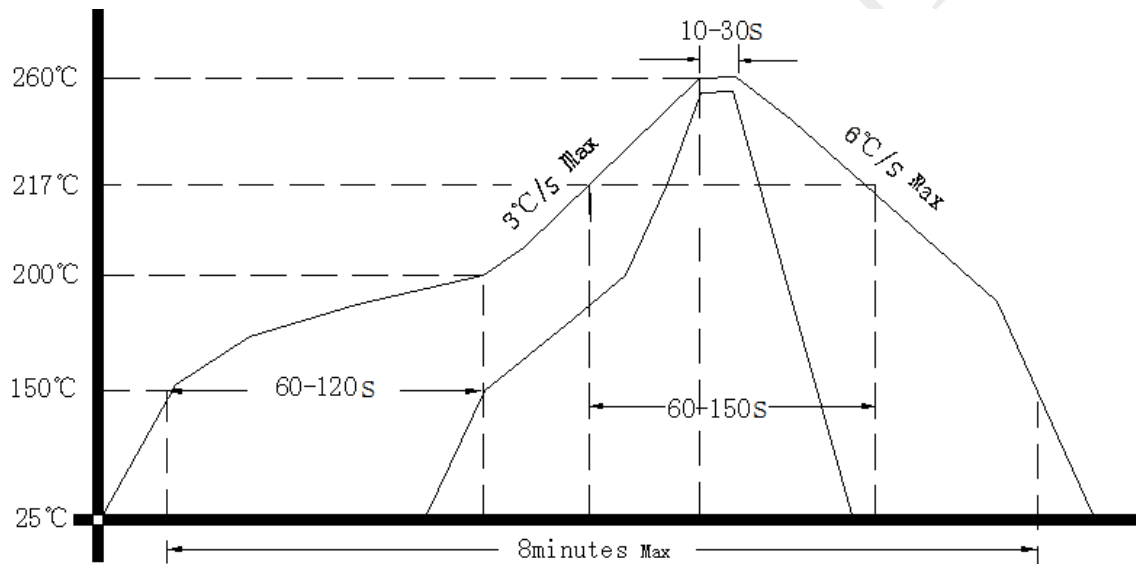

5. Package: Tape & Reel (mm)

