

Travelling Merchant: _____

DATASHEET

Standard: T21-A573-26.00MHz-A

P/N: _____

Plot			The Label
Drew	Audited	Approved	Stamp, please! Thanks!
Date: 2020.12.07			

Guangdong Dapu Telecom Technology Co.,Ltd

Bldg13-16,.N.Ind.Zone,SSL Industry Park, Dongguan City, Guangdong Province, China

TEL: 0086-0769-88010888 FAX: 0086-0769-81800098



1. Electrical Parameters

MODEL: T21-A573-26.00MHz-A						
Item	Description	Parameters			Unit	Test Condition
		Min.	Typ.	Max.		
Output	Frequency	26.00			MHz	
	Output Waveform	Clipped Sine Wave				
	V _{p-p}	0.7		1.2	V	
	Load	10KΩ//10pF				
Frequency Stabilities	Frequency Tolerance	-2		+2	× 10 ⁻⁶	@25°C
	vs. Temperature Range	-1.5		+1.5	× 10 ⁻⁶	T _A varied from -30°C to 85°C, measurement referenced to frequency observed with T _A =25°C, V _{cc} =1.8V, V _c =0.9V, O _{load} =10KΩ//10pF, temperature variable speed less than 2°C per minute.
	Frequency Tolerance vs. Supply Voltage	-0.2		+0.2	× 10 ⁻⁶	measurement referenced to frequency observed TA=25°C, V _{cc} varied from 1.70V to 1.90V, and O _{Load} =10KΩ//10pF
Frequency Stabilities	Frequency Tolerance vs. Load	-0.2		+0.2	× 10 ⁻⁶	10% load change measurement referenced to frequency observed with T _A =25°C, V _{cc} =1.8V, and O _{Load} =10KΩ//10pF.
	Aging Tolerance Per Day	-0.02		+0.02	× 10 ⁻⁶	T _A =25°C, V _{cc} =1.8V, and after 1h of operation.
	Aging Tolerance 1 Year	-1		+1	× 10 ⁻⁶	
Power Supply	Operating Current			2	mA	@25°C, V _{cc} =1.8V
	Supply Voltage	1.70	1.80	1.90	V	
Phase Noise	Phase Noise@25°C			-108	dBc/Hz	100Hz
				-130		1KHz
				-145		10KHz
				-148		100KHz
				-148		1MHz



Voltage Control Characteristics	Frequency Tuning Range			-8	$\times 10^{-6}$	$V_c=0.05V$. measurement referenced to $V_c=0.9V$	
		+7			$\times 10^{-6}$	$V_c=1.5V$. measurement referenced to $V_c=0.9V$	
		+10.5			$\times 10^{-6}$	$V_c=1.8V$. measurement referenced to $V_c=0.9V$	
	Tuning deviation	linearity	-20		+20	%	Relative to mean df/dV_{con}
	Tuning sensitivity				16	$\times 10^{-6}/V$	
	Input Impedance		100			$K\Omega$	
Environmental Conditions	Operable Temperature		-30		+85	$^{\circ}C$	
	Storage Temperature		-40		+90	$^{\circ}C$	
	ESD Level		Human Body Model,class2: 2000V to 4000V; ANSI/ESDA/JEDEC JS-001-2010. Machine Model, class B: 200V to 400V; JEDEC JESD22-A115C.				
	Moisture Sensitivity Level		Level 2.				
	Vibration		Test Condition: 0.75mm ;acceleration:10g;10Hz~2000Hz, one cycle per 30 min, test 2 hour. (3 times for each 3 directions X , Y , Z).IEC 68-2-06 Test Fc.				
	Shock		100g; 6ms; half sine wave (3 times for each 3 directions X , Y, Z),IEC 68-2-27 Test Ea/Severity 50A.				
Full Package Storage	Relative humidity (%)		20% ~ 70%				
	Temperature ($^{\circ}C$)		-10~35 $^{\circ}C$				



2. Mechanical Structure(mm)

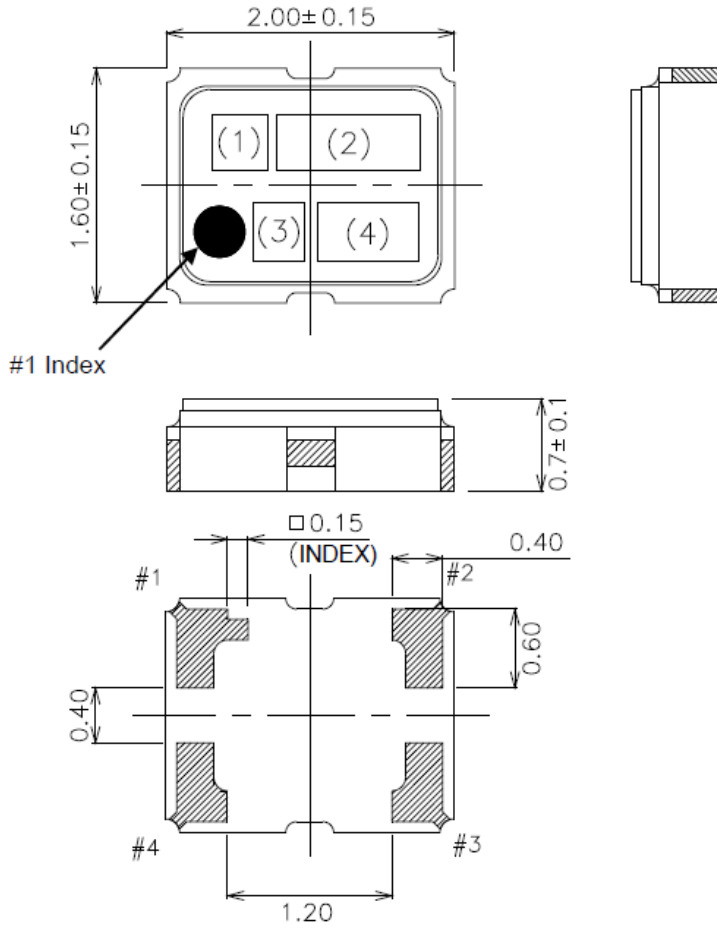

Pin Connections

Pin No.	Connection
#1	V_{CONT}
#2	GND
#3	Output
#4	V_{CC}

Marking

(1) Model code	AN
(2) Frequency	26.0 (MHz, 3digits)
(3) Logo	D
(4) Date code	Year (1digit) +Week (2digits) e.g.2017/1/1 → 701

unit: mm

Dimensional Tolerance: ± 0.15

(Unless otherwise noted)

DAPU CC



3. Test Circuit

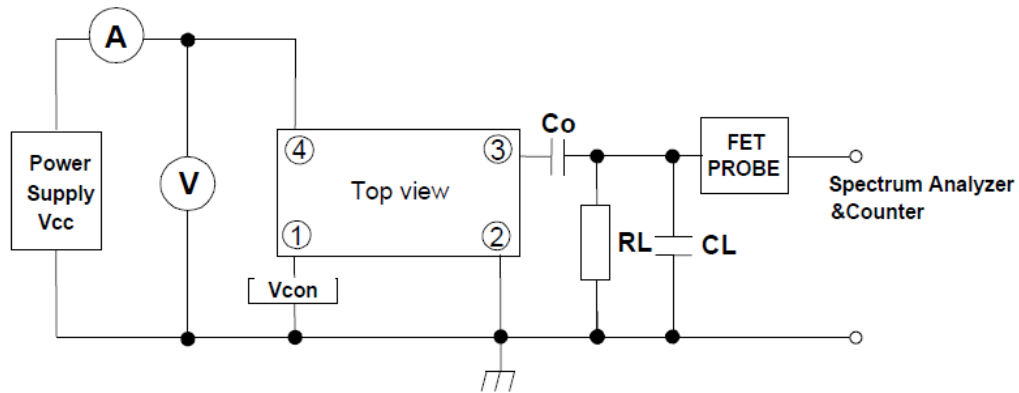

4. Reflow Soldering Curve (RoHS)

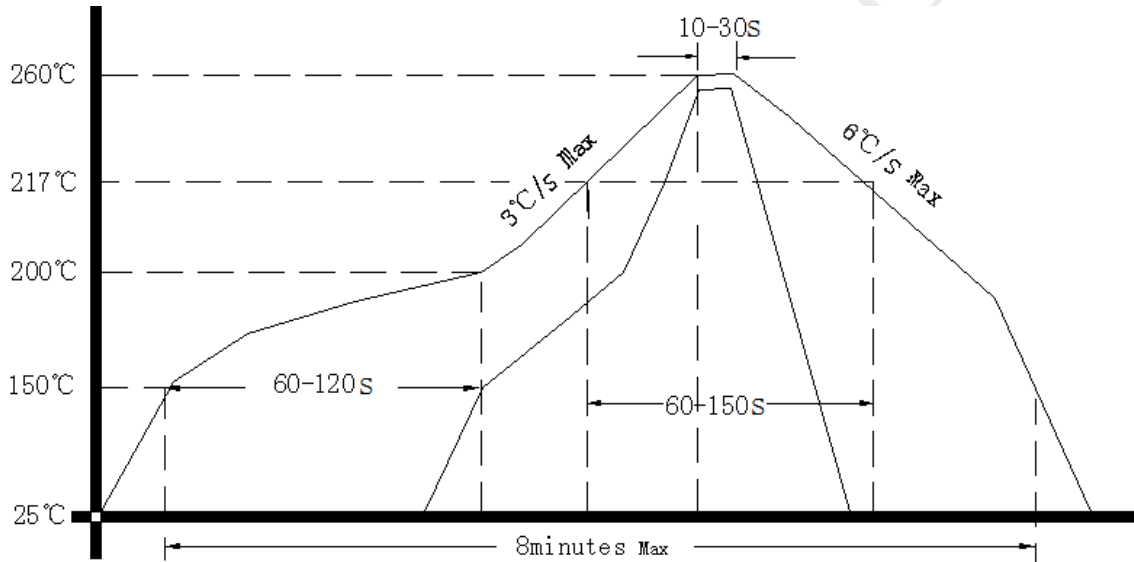

5. Package: Tape & Reel (mm)

