

Customer Code : \_\_\_\_\_

# DATASHEET

DAPU P/N: M11A-L444-32.512MHz

Customer P/N: \_\_\_\_\_

DAPU			Customer Approval
Drew	Audited	Approved	Stamp, please! Thanks!
<i>Amway.wei</i>	<i>Jerry.Yue</i>	<i>James.Liu</i>	
Date: 2016.03.25			

## Guangdong Dapu Telecom Technology Co.,Ltd

Bldg 16,.N.Ind.Zone,SSL Industry Park, Dongguan City, Guangdong Province, China

TEL: 0086-0769-88010888 FAX: 0086-0769-81800098





## 1. Electrical Parameters

MODEL: M11A-L444-32.512MHz						
Item	Description	Parameters			Unit	Test Condition
		Min.	Typ.	Max.		
Output	Frequency	32.512			MHz	
	Output Waveform	Sine Wave				
	Level	6			dBm	
	Harmonics Suppression			-30	dBc	
	Spurious Suppression			-60	dBc	
	Load	50			$\Omega$	
Frequency Stabilities	Frequency Tolerance vs. Operating Temperature Range	-0.5		+0.5	$\times 10^{-6}$	$T_A$ varied from $-40^\circ\text{C}$ to $85^\circ\text{C}$ , measurement referenced to frequency observed with $T_A=25^\circ\text{C}$ , $V_{cc}=12.0\text{V}$ , $V_c=2.5\text{V}$ , $O_{load}=50\Omega$ , temperature variable speed less than $2^\circ\text{C}$ per minute.
	Initial Frequency Tolerance	-1		+1	$\times 10^{-6}$	Measurement referenced to frequency observed with $T_A=25^\circ\text{C}$ , $V_{cc}=12.0\text{V}$ , $V_c=2.5\text{V}$ within 30 days after ex-works.
	Frequency Tolerance vs. Supply Voltage	-0.1		+0.1	$\times 10^{-6}$	measurement referenced to frequency observed $T_A=25^\circ\text{C}$ , $V_{cc}$ varied from 11.4V to 12.6V, $V_c=2.5\text{V}$ and $O_{Load}=50\Omega$ .
	Frequency Tolerance vs. Load	-0.1		+0.1	$\times 10^{-6}$	5% load change measurement referenced to frequency observed with $T_A=25^\circ\text{C}$ , $V_{cc}=12.0\text{V}$ , $V_c=2.5\text{V}$ , $O_{Load}=50\Omega$ .
	Aging Tolerance Per Day	-0.02		+0.02	$\times 10^{-6}$	$T_A=25^\circ\text{C}$ , $V_{cc}=12.0\text{V}$ , $V_c=2.5\text{V}$ and after 1h of operation.
	Aging Tolerance 1 Year	-1		+1	$\times 10^{-6}$	
Power Supply	Current Consumption			15	mA	@ $25^\circ\text{C}$ , $V_{cc}=12.0\text{V}$ , $V_c=2.5\text{V}$ , $O_{load}=50\Omega$ .
	Supply Voltage	11.4	12.0	12.6	V	



Voltage Control Characteristics	Frequency Tuning Range	-10		-5	$\times 10^{-6}$	$V_c=0V$ . measurement referenced to $V_c=2.5V$
		-1		+1	$\times 10^{-6}$	$V_c=2.5$ . measurement referenced to exactly 32.512MHz
		+5		+10	$\times 10^{-6}$	$V_c=5.0V$ . measurement referenced to $V_c=2.5V$
	Linearity			10	%	
	Slope	Positive				
	Input Impedance	100				K $\Omega$
Phase Noise	Phase Noise @25°C		-130	-125	dBc/Hz	1KHz
Environmental Conditions	Operable Temperature	-40		+85	°C	
	Storage Temperature	-55		+105	°C	
	ESD Level	Human Body Model,class2: 2000V to 4000V; ANSI/ESDA/JEDEC JS-001-2010.				
		Machine Model, class B: 200V to 400V; ANSI/ESDA/JEDEC JS-001-2010.				
	Moisture Sensitivity Level	Not humidity sensitive.				
	Vibration	Test Condition: 0.75mm ;acceleration:10g;10Hz~2000Hz, one cycle per 30 min, test 2 hour. (3 times for each 3 directions X , Y , Z) .IEC 68-2009 Test Fc.				
Shock	100g; 6ms; half sine wave (3 times for each 3 directions X , Y , Z ),IEC 68-2009 Test Ea/Severity 50A.					
Full Package Storage	Relative humidity (%)	20%~70%				
	Temperature (°C)	-10~35°C				



## 2. Mechanical Structure(mm)

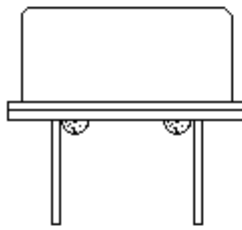
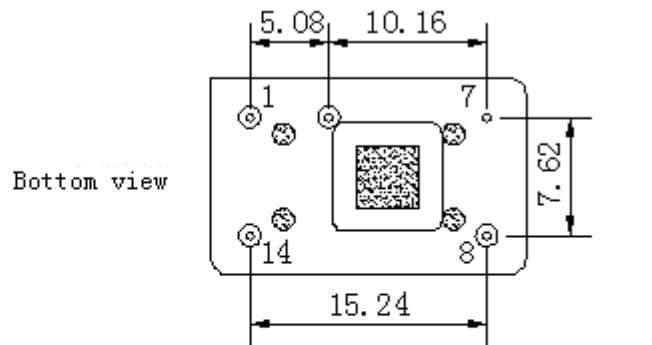

Side view

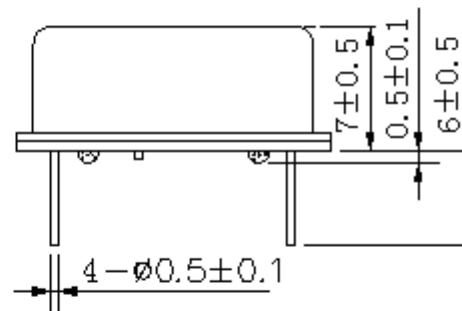

PIN FUNCTION

PIN	NOTATION	FUNCTION
1	VC	Control Voltage
7	GND	GND
8	OUTPUT	RF Output
14	VCC	Supply Voltage

Top view

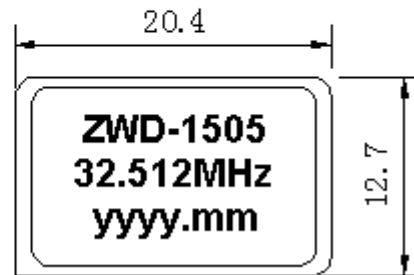

**Note1:** Tolerance  $\pm 0.20\text{mm}$  without mark

**Note2:** The yyyy representative: year  
The mm representative: month

**Note3:** Referential Weight 4.2g



### 3. Test circuit

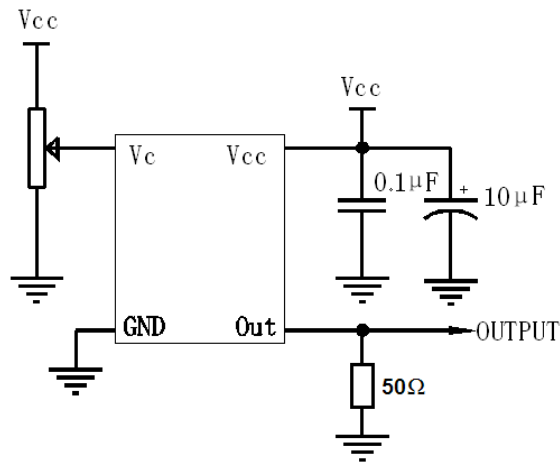

### 4. Reflow Soldering Curve (RoHS)

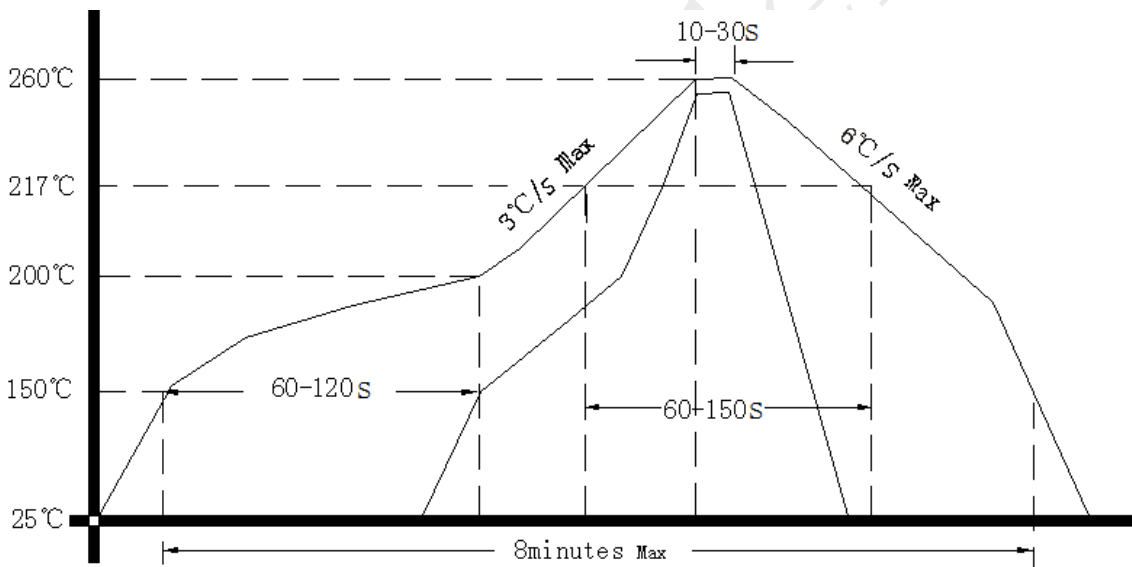

### 5. Package: PVC Tube,10pcs (mm)

