

Customer Code : _____

DATASHEET

DAPU P/N: 022A-Q426-10.00MHz-A

Customer P/N: _____

DAPU			Customer Approval
Drew	Audited	Approved	Stamp, please! Thanks!
Date: 2020.07.28			

Guangdong Dapu Telecom Technology Co.,Ltd

Bldg 16,.N.Ind.Zone,SSL Industry Park, Dongguan City, Guangdong Province, China

TEL: 0086-0769-88010888 FAX: 0086-0769-81800098



1. Electrical Parameters

MODEL: O22A-Q426-10.00MHz-A						
Item	Description	Parameters			Unit	Test Condition
		Min.	Typ.	Max.		
Output	Frequency	10.00			MHz	
	Output Waveform	Sine wave				
	Level	10			dBm	
	Load	50			Ω	
	Harmonics Suppression			-30	dBc	
	Spurious Suppression			-75	dBc	
	Frequency Tolerance vs. Operating Temperature Range	-0.03		+0.03	$\times 10^{-6}$	T_A varied from -40°C to 75°C , measurement referenced to frequency observed with $f_{\text{ref}}=(f_{\text{max}}+f_{\text{min}})/2$, $V_{\text{cc}}=5.0\text{V}$, $O_{\text{load}}=50\Omega$, temperature variable speed less than 2°C per minute.
	Initial Frequency Tolerance	-0.1		+0.1	$\times 10^{-6}$	Measurement referenced to frequency observed with $T_A=25^\circ\text{C}$, $V_{\text{cc}}=5.0\text{V}$, $V_c=2.5\text{V}$ and after 30 minutes of operation, within 30 days after ex-works.
	Frequency Tolerance vs. supply voltage	-3		+3	$\times 10^{-9}$	measurement referenced to frequency observed $T_A=25^\circ\text{C}$, V_{cc} varied from 4.5V to 5.5V, $V_c=2.5\text{V}$, $O_{\text{load}}=50\Omega$.
	Frequency Tolerance vs. Load	-3		+3	$\times 10^{-9}$	5% Load Change Measurement referenced to frequency observed with $T_A=25^\circ\text{C}$, $V_{\text{cc}}=5.0\text{V}$, $V_c=2.5\text{V}$, $O_{\text{load}}=50\Omega$.
	Aging Tolerance per day	-1		+1	$\times 10^{-9}$	V_{cc}, V_c, T_A constant Measurement referenced to frequency observed with $T_A=25^\circ\text{C}$, $V_{\text{cc}}=5.0\text{V}$, $V_c=2.5\text{V}$, $O_{\text{load}}=50\Omega$ and after 30 days of operation.
Aging Tolerance 1Year	-0.1		+0.1	$\times 10^{-6}$		



Power Supply	Supply Voltage	4.5	5.0	5.5	V	
	Steady Consumption			230	mA	@25°C
	Warm up current			700	mA	
	Warm up Time			7	minutes	@25°C within $\pm 0.01 \times 10^{-6}$ of final frequency with reference after 1H on.
Voltage Control Characteristics	Frequency Tuning Range			-0.7	$\times 10^{-6}$	$V_c=0V$. measurement referenced to $V_c=2.5V$.
		-0.1		+0.1	$\times 10^{-6}$	$V_c=2.5V$. measurement referenced to exactly 10.00MHz.
		+0.7			$\times 10^{-6}$	$V_c=5.0V$. measurement referenced to $V_c=2.5V$.
	Linearity			10	%	
	Slope	Positive				
	Input Impedance	100				K Ω
Phase Noise	Phase Noise		-85			1Hz
			-125			10Hz
			-145			100Hz
			-150			1KHz
			-155			10KHz
Environmental Conditions	Operable Temperature	-40		+75	°C	
	Storage Temperature	-55		+100	°C	
	ESD Level	Human Body Model, class2: 2000V to 4000V; ANSI/ESDA/JEDEC JS-001-2010.				
		Machine Model, class B: 200V to 400V; JEDEC JESD22-A115C.				
	Moisture Sensitivity Level	Not humidity sensitive.				
	Vibration	Frequency range: 20Hz~2000Hz, acceleration : 6g , ASD:0.04g ² /Hz one cycle per 30 min, test 2 hour. (3 times for each 3 directions X , Y , Z), GJB 150.16A-2009				
Shock	100g; 6ms; half sine wave (3 times for each 3 directions X , Y , Z),GJB 360B-2009					
Full Package Storage	Relative humidity (%)	20%~70%				
	Temperature (°C)	-10~35°C				



2. Mechanical Structure (mm)

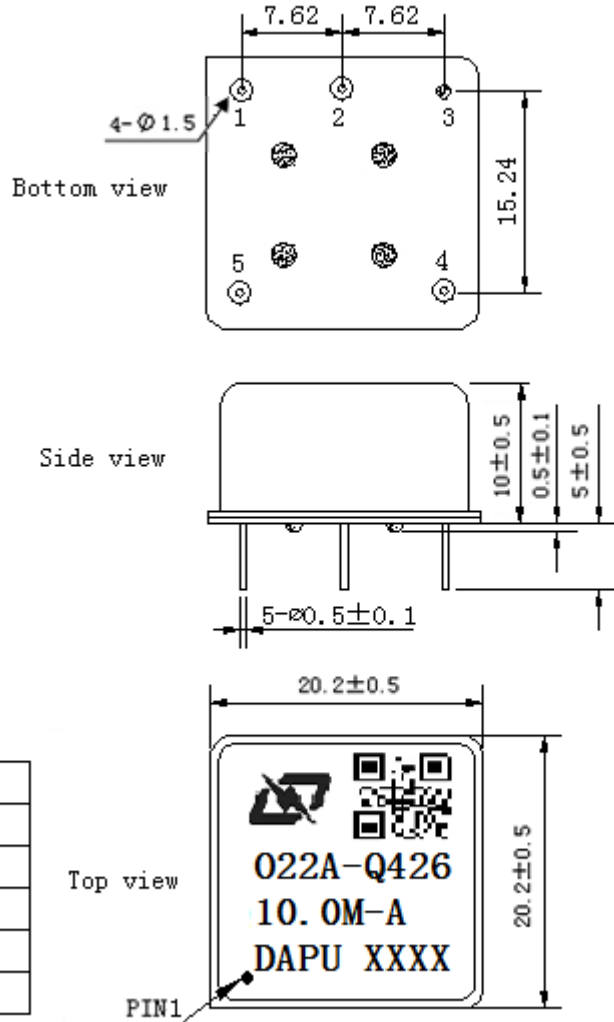

PIN FUNCTION

PIN	NOTATION	FUNCTION
1	VCC	Supply Voltage
2	OUTPUT	RF Output
3	GND	GND
4	VC	Control Voltage
5	NC	Not Connect

- Note1:** Tolerance ±0.20mm without mark
- Note2:** The first two xx representative: week
After two xx representative: year
- Note3:** Referential weight 8.0g
- Note4:** NC is not connect



3. Test Circuit

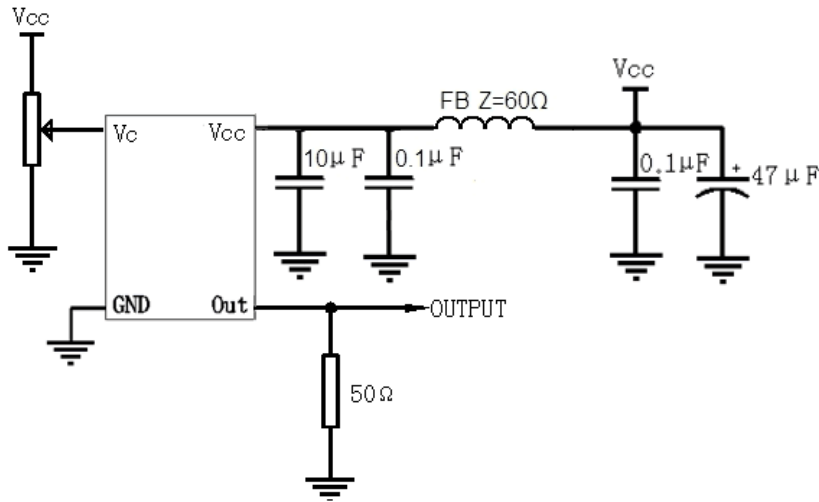

4. Reflow Soldering Curve (RoHS)

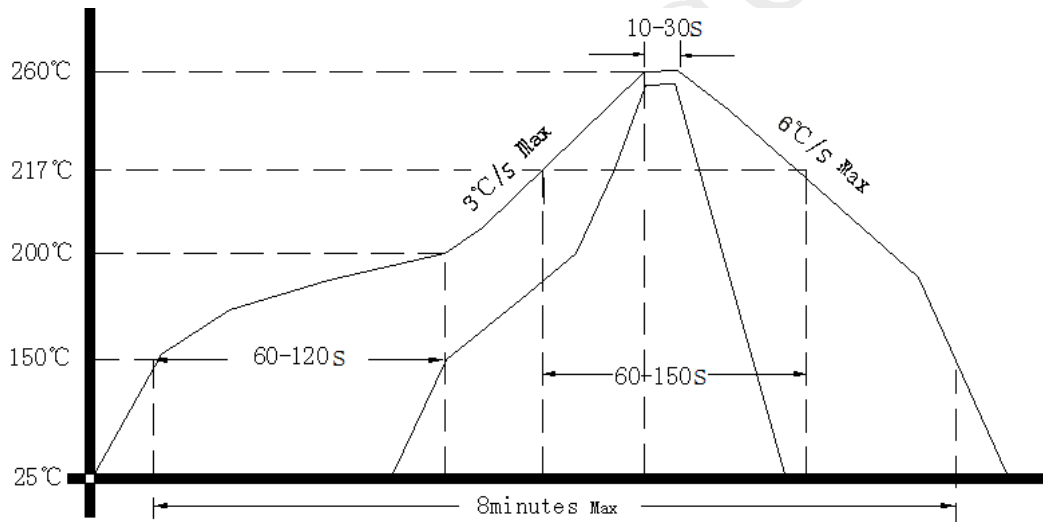

5. Package(mm)

