

Travelling Merchant: \_\_\_\_\_

# DATASHEET

Standard:           **O11A-L427-100.00MHz**          

P/N: \_\_\_\_\_

Plot			The Label
Drew	Audited	Approved	Stamp, please! Thanks!
Date: 2020.07.22			

## Guangdong Dapu Telecom Technology Co.,Ltd

Bldg13-16,.N.Ind.Zone,SSL Industry Park, Dongguan City, Guangdong Province, China

TEL: 0086-0769-88010888    FAX: 0086-0769-81800098





## 1. Electrical Parameters

MODEL: O11A-L427-100.00MHz						
Item	Description	Parameters			Unit	Test Condition
		Min.	Typ.	Max.		
Output	Frequency	100.00			MHz	
	Output Waveform	Sine wave				
	Level	7			dBm	
	Load	50			$\Omega$	
	Harmonics Suppression			-25	dBc	
	Spurious Suppression			-70	dBc	
Frequency Stabilities	Frequency Tolerance vs. Operating Temperature Range	-0.05		+0.05	$\times 10^{-6}$	$T_A$ varied from -40°C to 85°C, measurement referenced to frequency observed with $f_{ref}=(f_{max}+f_{min})/2$ , $V_{cc}=5.0V$ , $O_{load}=50\Omega$ , temperature variable speed less than 2°C per minute.
	Initial Frequency Tolerance	-0.5		+0.5	$\times 10^{-6}$	Measurement referenced to frequency observed with $T_A=25^\circ C$ , $V_{cc}=5.0V$ , $V_c=2.5V$ , and after 15 minutes of operation, within 30 days after ex-works.
	Frequency Tolerance vs. Supply Voltage	-0.1		+0.1	$\times 10^{-6}$	measurement referenced to frequency observed $T_A=25^\circ C$ , $V_{cc}$ varied from 4.75V to 5.25V, $V_c=2.5V$ and $O_{load}=50\Omega$ .
	Frequency Tolerance vs. Load	-0.1		+0.1	$\times 10^{-6}$	5% load change measurement referenced to frequency observed with $T_A=25^\circ C$ , $V_{cc}=5.0V$ , $V_c=2.5V$ , and $O_{load}=50\Omega$ .
	Short-Term Stability: Allan Variance			0.1	$\times 10^{-9}$	Temperature stability, no EMI\EMC or other interference, test after power for 1hour ref. to 25°C; 1s, using PN9000 equipment.
	Aging Tolerance 1 Year	-0.3		+0.3	$\times 10^{-6}$	$V_{cc}$ , $V_c$ , $T_A$ constant measurement referenced to frequency observed with $T_A=25^\circ C$ , $V_{cc}=5.0V$ , $V_c=2.5V$ and after 30 days of operation.



Power Supply	Supply Voltage	4.75	5.0	5.25	V	
	Steady Consumption			300	mA	@25°C
	Warm up current			600	mA	
Voltage Control Characteristics	Frequency Tuning Range			-3	$\times 10^{-6}$	$V_c=0V$ . measurement referenced to $V_c=2.5V$
		-0.5		+0.5	$\times 10^{-6}$	$V_c=2.5V$ . measurement referenced to exactly 100.00MHz
		+3			$\times 10^{-6}$	$V_c=5.0V$ . measurement referenced to $V_c=2.5V$
	Linearity			10	%	
	Slope	Positive				
	Input Impedance	100			K $\Omega$	
Phase Noise	Phase Noise @25°C			-145	dBc/Hz	1KHz
Environmental Conditions	Operable Temperature	-40		+85	°C	
	Storage Temperature	-55		+105	°C	
	ESD Level	Human Body Model, class2: 2000V to 4000V; ANSI/ESDA/JEDEC JS-001-2010.				
		Machine Model, class B: 200V to 400V; JEDEC JESD22-A115C.				
	Moisture Sensitivity Level	Not humidity sensitive.				
	Vibration	Test Condition: 0.75mm ;acceleration:10g;10Hz~500Hz, one cycle per 30 min, test 2 hour. (3 times for each 3 directions X , Y , Z), IEC 68-2-06 Test Fc.				
Shock	50g; 11ms; half sine wave (3 times for each 3 directions X, Y, Z), IEC 68-2-27 Test Ea/Severity 50A.					



## 2. Mechanical Structure (mm)

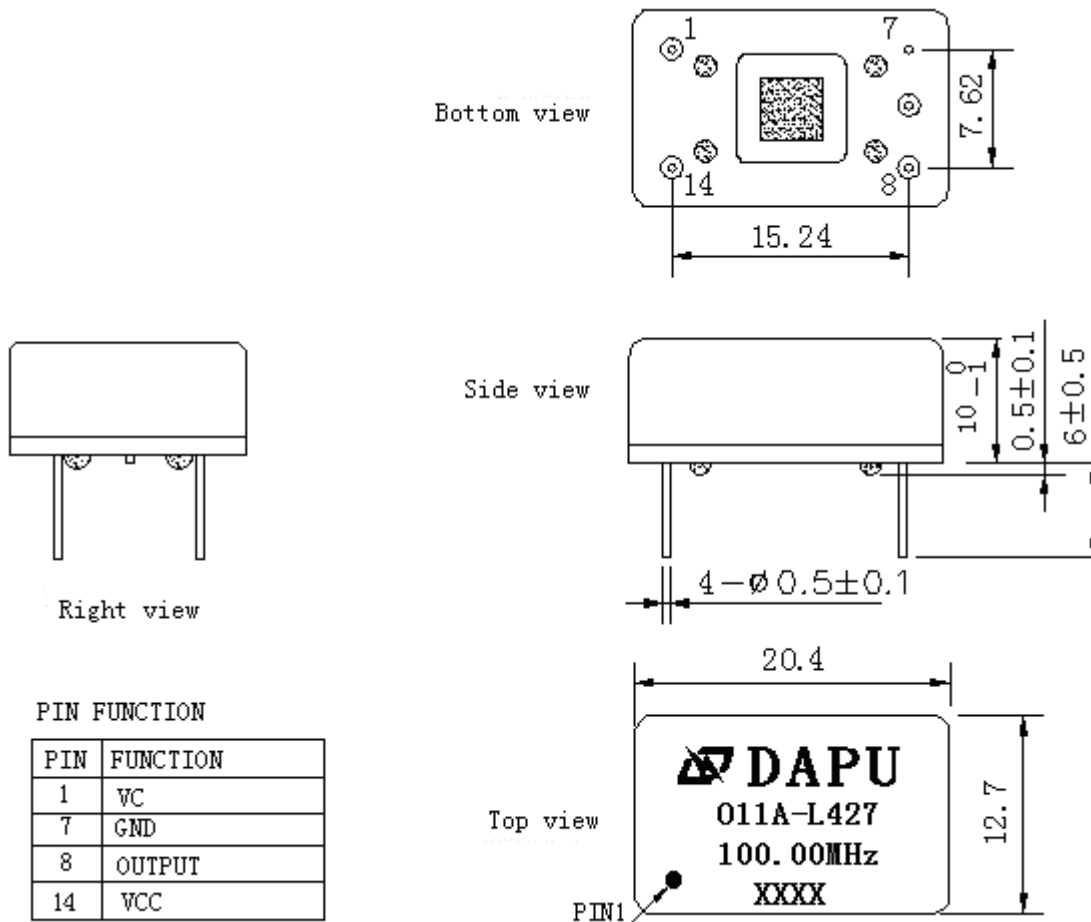

**Note1:** Tolerance ±0.2mm without mark

**Note2:** The first two xx representative: week  
After two xx representative: year

**Note3:** Referential Weight 8.0g



### 3. Test Circuit

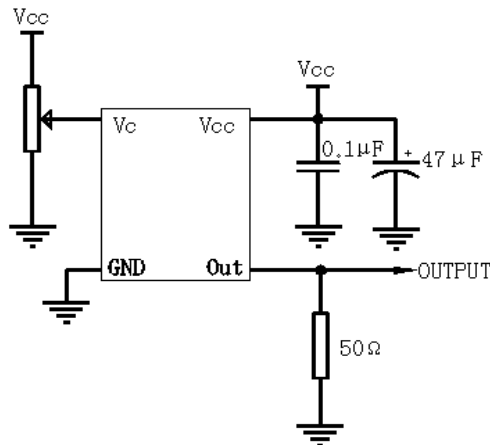

### 4. Reflow Soldering Curve (RoHS)

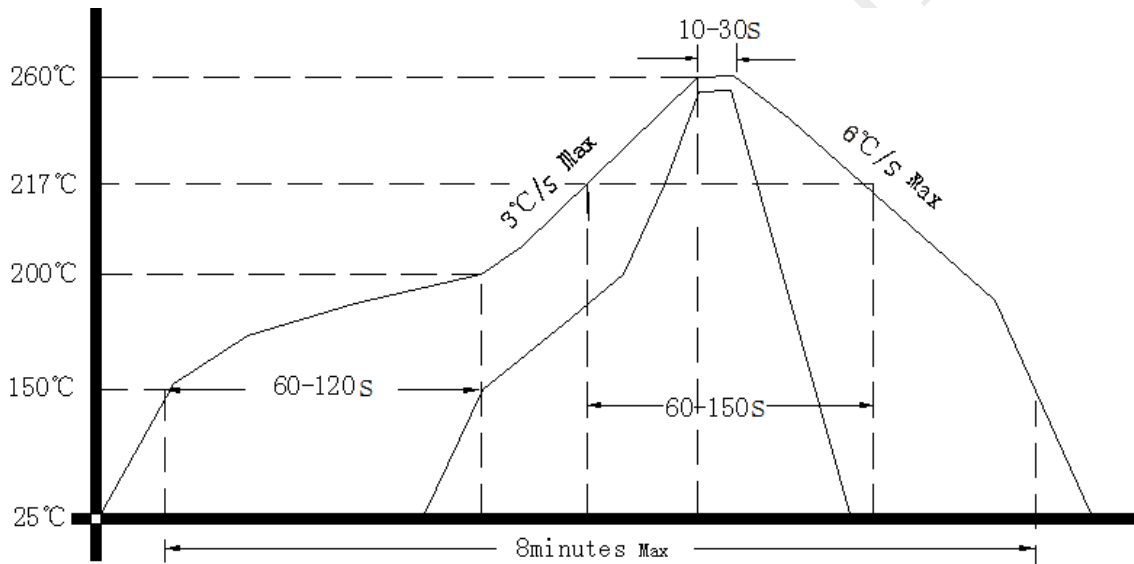

### 5. Package: Tape & Reel (mm)

