

Travelling Merchant: _____

DATASHEET

Standard: **O11F-X411-100.00MHz**

P/N: _____

| Plot | | | The Label |
|------------------|---------|----------|------------------------|
| Drew | Audited | Approved | Stamp, please! Thanks! |
| | | | |
| Date: 2020.07.21 | | | |

Guangdong Dapu Telecom Technology Co.,Ltd

Bldg13-16,.N.Ind.Zone,SSL Industry Park, Dongguan City, Guangdong Province, China

TEL: 0086-0769-88010888 FAX: 0086-0769-81800098



1. Electrical Parameters

| MODEL: O11F-X411-100.00MHz | | | | | | |
|----------------------------|---|------------|------|-------|------------------|---|
| Item | Description | Parameters | | | Unit | Test Condition |
| | | Min. | Typ. | Max. | | |
| Output | Frequency | 100.00 | | | MHz | |
| | Output Waveform | Sine wave | | | | |
| | Level | 6 | | | dBm | |
| | Load | 50 | | | Ω | |
| | Harmonics Suppression | | | -30 | dBc | |
| | Spurious Suppression | | | -60 | dBc | |
| Frequency Stabilities | Frequency Tolerance vs. Operating Temperature Range | -0.05 | | +0.05 | $\times 10^{-6}$ | T_A varied from -40°C to 85°C , measurement referenced to frequency observed with $f_{\text{ref}}=(f_{\text{max}}+f_{\text{min}})/2$, $V_{\text{cc}}=3.3\text{V}$, $V_c=1.65\text{V}$, $O_{\text{load}}=50\Omega$, temperature variable speed less than 2°C per minute. |
| | Initial Frequency Tolerance | -0.5 | | +0.5 | $\times 10^{-6}$ | Measurement referenced to frequency observed with $T_A=25^\circ\text{C}$, $V_{\text{cc}}=3.3\text{V}$, $V_c=1.65\text{V}$ and after 15 minutes of operation, within 30 days after ex-works. |
| | Frequency Tolerance vs. supply voltage | -0.05 | | +0.05 | $\times 10^{-6}$ | measurement referenced to frequency observed $T_A=25^\circ\text{C}$, V_{cc} varied from 3.13V to 3.47V, $V_c=1.65\text{V}$, $O_{\text{load}}=50\Omega$. |
| | Frequency Tolerance vs. Load | -0.05 | | +0.05 | $\times 10^{-6}$ | 5% Load Change Measurement referenced to frequency observed with $T_A=25^\circ\text{C}$, $V_{\text{cc}}=3.3\text{V}$, $V_c=1.65\text{V}$, $O_{\text{load}}=50\Omega$. |
| | Short Term Stability | | | 0.1 | $\times 10^{-9}$ | Temperature stability, no EMI\EMC or other interference, test after power for 1hour ref. to 25°C ; 1s. |
| | Aging Tolerance per day | -0.02 | | +0.02 | $\times 10^{-6}$ | V_{cc}, V_c, T_A constant Measurement referenced to frequency observed with $T_A=25^\circ\text{C}$, $V_{\text{cc}}=3.3\text{V}$, $V_c=1.65\text{V}$, $O_{\text{load}}=50\Omega$ and after 30 days of operation. |
| | Aging Tolerance 1Year | -1.0 | | +1.0 | $\times 10^{-6}$ | |



| | | | | | | |
|---------------------------------|--|---|------|------|------------------|--|
| Power Supply | Supply Voltage | 3.13 | 3.3 | 3.47 | V | |
| | Current Consumption | | | 300 | mA | @25°C |
| | Current Consumption during warm up | | | 600 | mA | |
| | Warm-Up Time | | | 5 | min | @25°C within $\pm 0.1 \times 10^{-6}$ of final frequency with reference after 1 hour on. |
| Voltage Control Characteristics | Frequency Tuning Range | -8 | | -3 | $\times 10^{-6}$ | $V_c=0V$. measurement referenced to $V_c=1.65V$. |
| | | -0.5 | | +0.5 | $\times 10^{-6}$ | $V_c=1.65V$. measurement referenced to exactly 100.00MHz. |
| | | +3 | | +8 | $\times 10^{-6}$ | $V_c=3.3V$. measurement referenced to $V_c=1.65V$. |
| | Linearity | | | 10 | % | |
| | Slope | Positive | | | | |
| | Input Impedance | 100 | | | K Ω | |
| Phase Noise | Phase Noise | | -85 | -75 | dBc/Hz | 10Hz |
| | | | -120 | -110 | | 100Hz |
| | | | -145 | -140 | | 1KHz |
| | | | -155 | -150 | | 10KHz |
| | | | -155 | -150 | | 100KHz |
| | | | -155 | -150 | | 1MHz |
| | | | -155 | -150 | | |
| Environmental Conditions | Operable Temperature | -40 | | +85 | °C | |
| | Storage Temperature | -55 | | +105 | °C | |
| | ESD Level | Human Body Model, class2: 2000V to 4000V; ANSI/ESDA/JEDEC JS-001-2010. | | | | |
| | | Machine Model, class B: 200V to 400V; JEDEC JESD22-A115C. | | | | |
| | Moisture Sensitivity Level | Level 2. | | | | |
| | Vibration | Test Condition: 0.75mm ;acceleration:10g;10Hz~500Hz, one cycle per 30 min, test 2 hour. (3 times for each 3 directions X , Y , Z), IEC 68-2-06 Test Fc. | | | | |
| Shock | 50g; 11ms; half sine wave (3 times for each 3 directions X , Y , Z),IEC 68-2-27 Test Ea/Severity 50A. | | | | | |
| Full Package Storage | Relative humidity (%) | 20% ~70% | | | | |
| | Temperature (°C) | -10~35°C | | | | |



2. Mechanical Structure (mm)

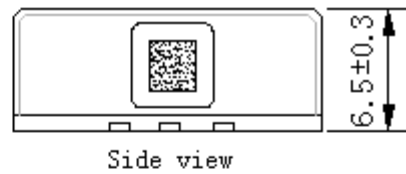
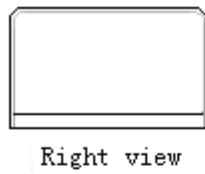
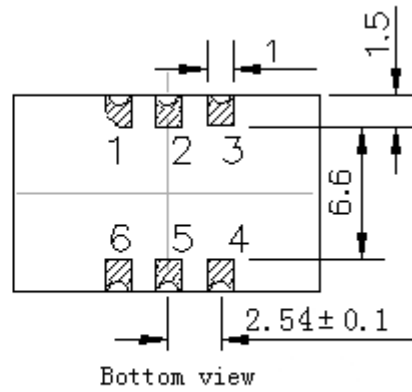
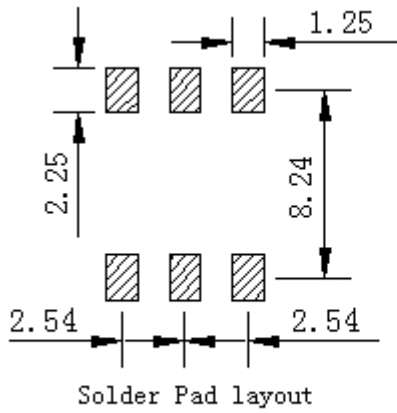

PIN FUNCTION

| PIN | NOTATION | FUNCTION |
|-----|----------|-----------------|
| 1 | VC | Control Voltage |
| 2,5 | NC | Not Connect |
| 3 | GND | GND |
| 4 | OUTPUT | RF Output |
| 6 | VCC | Supply Voltage |

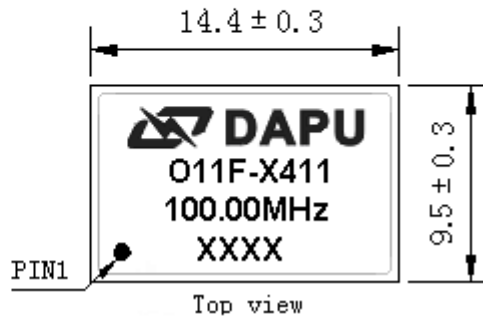

- Note1:** Tolerance $\pm 0.2\text{mm}$ without mark
- Note2:** The first two xx representative: week
After two xx representative: year
- Note3:** Referential weight 2.2g
- Note4:** NC is not connect



3. Test Circuit

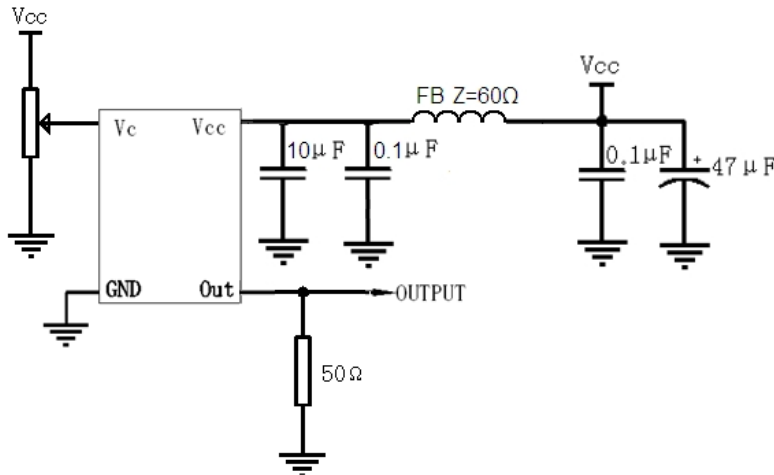

4. Reflow Soldering Curve (RoHS)

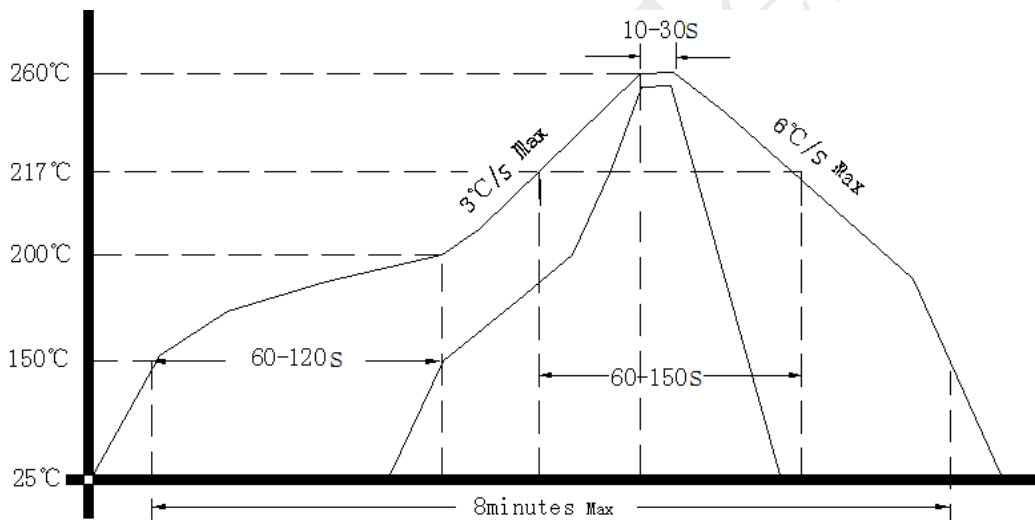

5. Package: Tape & Reel (mm)

