

Travelling Merchant: _____

DATASHEET

Standard: DP8Y20000003

Plot			The Label
Drew	Audited	Approved	Stamp, please! Thanks!
Date: 2020.07.01			

Guangdong Dapu Telecom Technology Co.,Ltd

Bldg13,.N.Ind.Zone,SSL Industry Park, Dongguan City, Guangdong Province, China

TEL: 0086-0769-88010888 FAX: 0086-0769-81800098



1、Electrical Parameters

MODEL: DP8Y2000003							
No.	Parameters	SYM.	Electrical Spec.				Notes
			Min.	Typ.	Max.	Units	
1	Nominal Frequency	FL	20.00			MHz	
2	Oscillation Mode	-	Fundamental				
3	Load Capacitance	CL	10			pF	
4	Initial Frequency Accuracy	-	-30		+30	ppm	at 25°C ±3°C
5	DLD	RLD2			60	Ω	10 nW to 100 uW step 10
6	Autoeciousness	SPDB			-3	dB	± 5300ppm of nominal Freq.
7	Aging	-	-2		+2	ppm	1st Year
8	Drive Level	DL	-	100	-	uW	
9	Resonance Resistance	Rr	-	-	60	Ω	
10	Shunt Capacitance	C0	-	-	2	pF	
11	Insulation Resistance	-	500	-	-	MΩ	at DC 100V
12	Operating Temperature Range	-	-40	~	+85	°C	Operating Temperature Range
13	Storage Temperature Range	-	-55	~	+125	°C	



2、Mechanical Structure(mm)

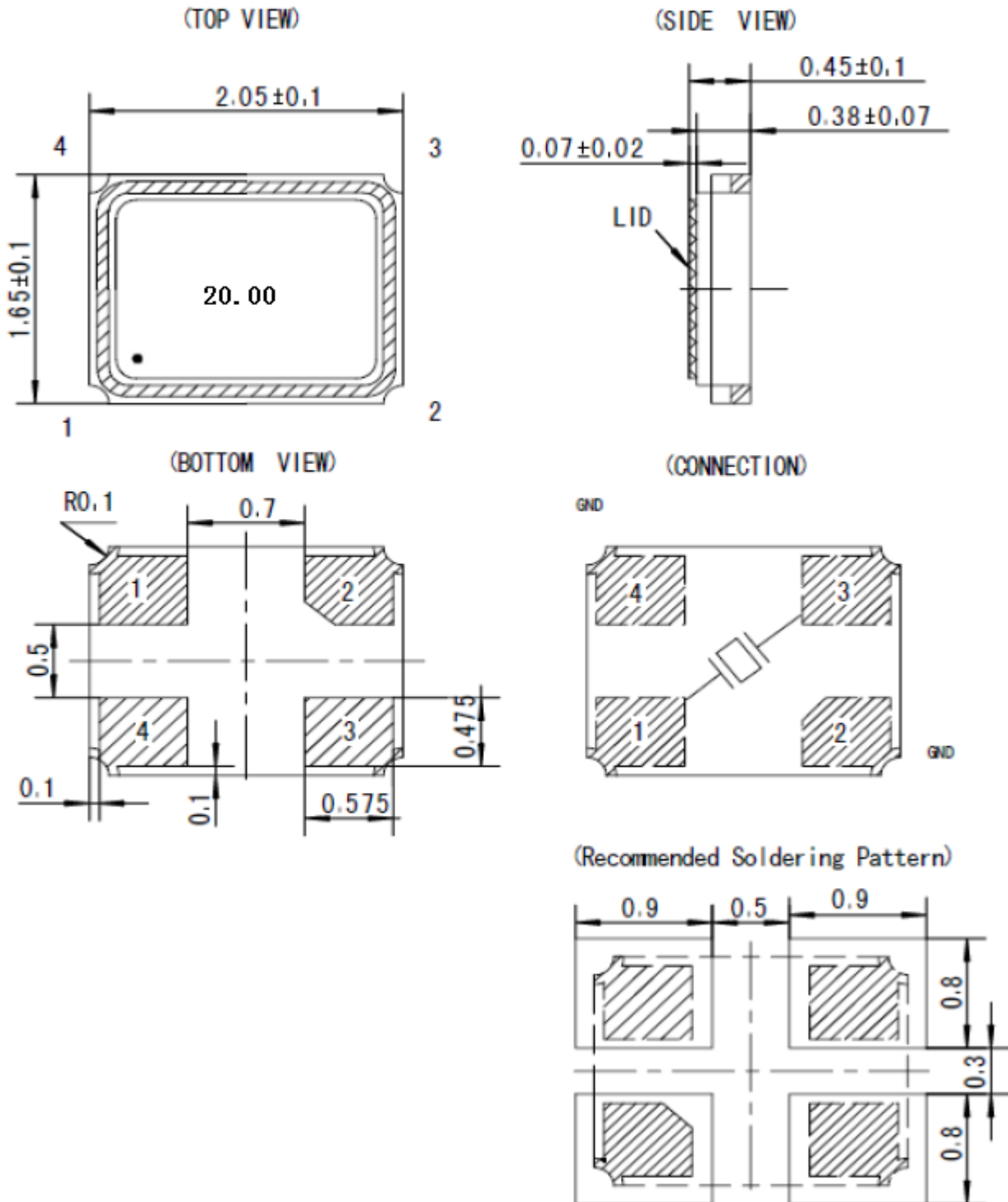



3、 Reflow Soldering Curve (RoHS)

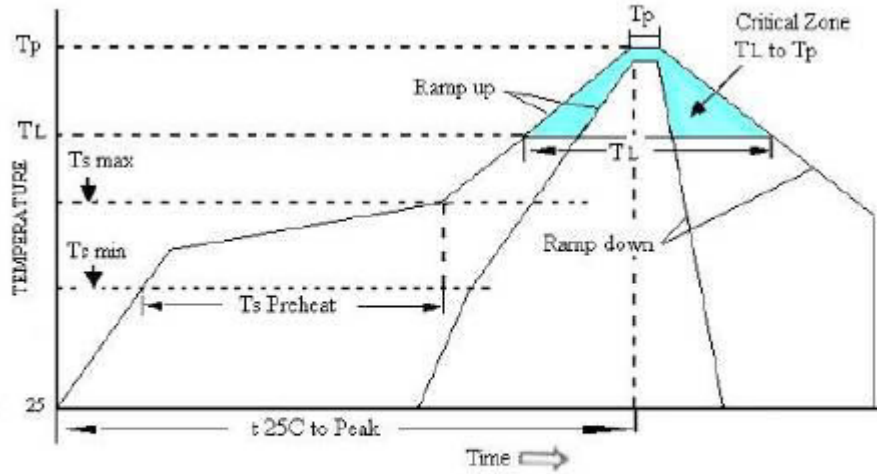

High Temperature Infrared /Convection

Note: Temperature shown are applied to body of device

Ts max to T_L (Ramp-up Rate)	3°C/second max
Preheat	
Temperature Min(T_s Min)	150°C
Temperature Typical(T_s Typ)	175°C
Temperature Max.(T_s Max)	200°C
Time(t_s)	60-180 seconds
Ram-up Rate(T_L to T_p)	3°C/second Max
Time Maintained Above:	
--Temperature(T_L)	217°C
--Time(T_L)	60-150seconds
Peak Temperature (T_p)	280°C Max for 10 seconds
Time within 5°C of actual peak(t_p)	20-40 seconds
Ramp-down Rate	6°C/seconds Max
Tune 25°C to Peak Temperature(t)	8 minutes Max
Moisture Sensitivity Level	Level 1

High Temperature Manual Soldering

Note: Temperature shown are applied to body of device

280°C Max for 10 seconds Max, 4 times Max



4、 Package: Tape & Reel (mm)

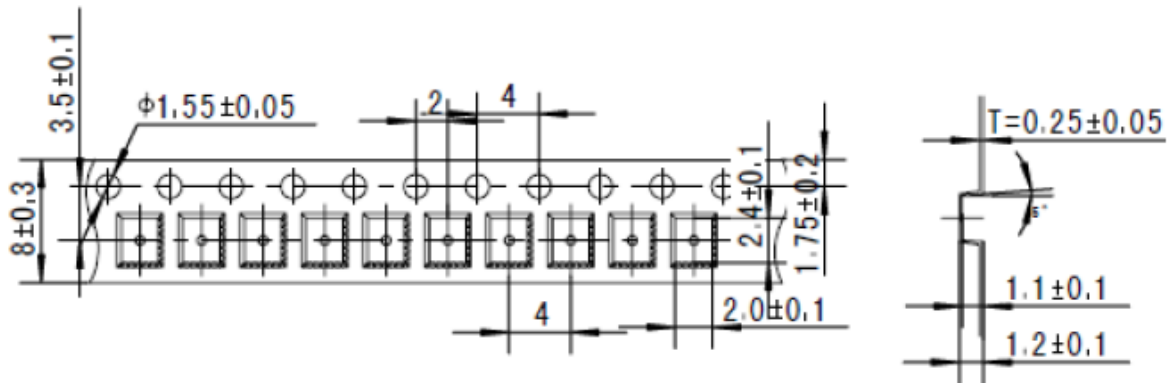

2. Dimensions of Reel

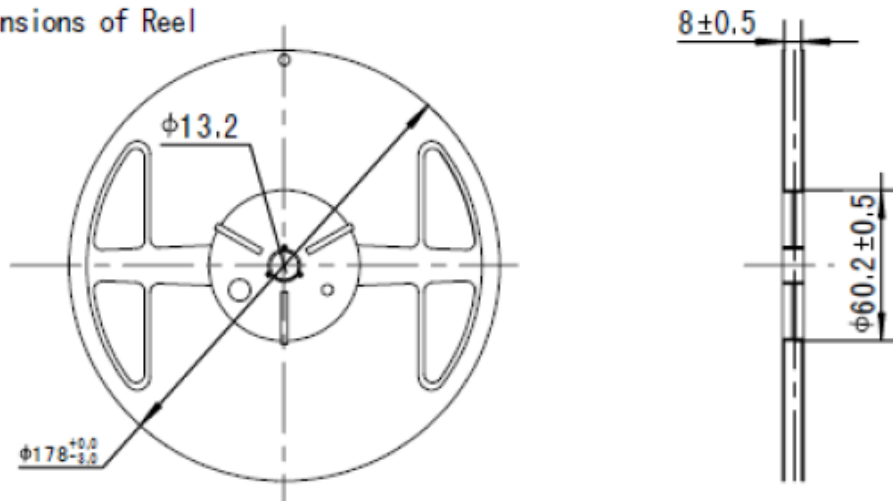

3. Packing

1 reel/box 1 reel=3000pcs

10 boxes/carton (the carton with bubble pad on four sides)

