

Customer Code :

DATASHEET

DAPU P/N: **CM30B-X125-10.00MHz**

Customer P/N: _____

DAPU			Customer Approval
Drew	Audited	Approved	Stamp, please! Thanks!
Date: 2019.06.27			

Guangdong Dapu Telecom Technology Co., Ltd

Bldg 16, N.Ind.Zone,SSL Industry Park,DongguanCity, Guangdong Province, China

TEL: 0086-0769-88010888 FAX: 0086-0769-81800098



Table of Content

1. GENERAL DESCRIPTION.....	4
2. PIN DEFINITION.....	5
3. ELECTRICAL PARAMETERS	5
4. PERFORMANCE.....	6
5. UART.....	7
6. CONTROL AND STATUS PINS.....	7
7. ENVIRONMENTAL CONDITIONS.....	8
8. TYPICAL APPLICATION	9
9. MECHANICAL STRUCTURE (MM)	10
10. WAVE SOLDERING CURVE (ROHS).....	11
11. PACKAGE (MM)	11



1. General Description

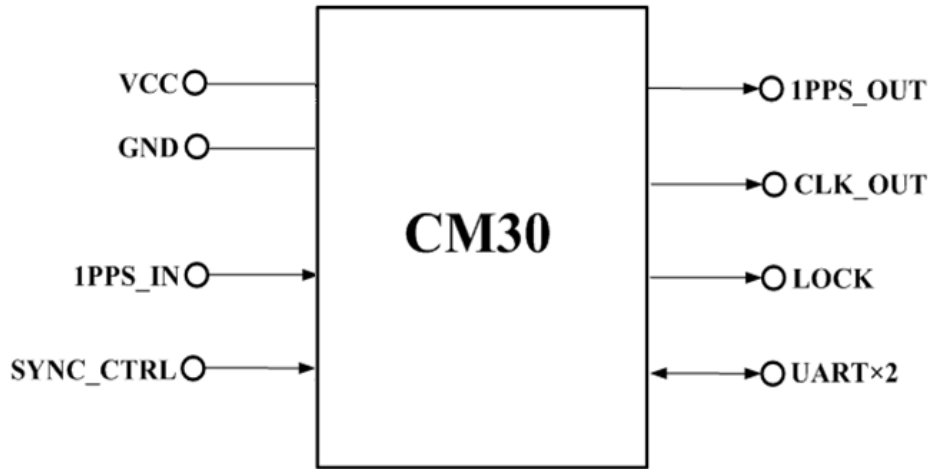

Figure 1 CM30

Figure 1 is the basic diagram of CM30. CM30 is a high-performance clock module designed to provide precise frequency and phase synchronizing with external time reference for telecom and other applications.

Key features:

- **Reference:** 1PPS and TOD from GNSS receiver, IEEE1588 etc.;
- **Temperature Stability:** ± 0.2 ppb;
- **Holdover:** $\pm 10\mu\text{s}/6\text{h}$ @ $\Delta T = \pm 20^\circ\text{C}$ after power up 7 days;
- **Clocks Input and Output:** 1*1PPS input, 1*1PPS output and 1*10MHz output;
- **Serial Interface:** 1*UART for TOD and management;
- **Mechanical Size:** 30mm*25mm*15mm.



2. Pin Definition

Table 1 Pin Definition

Pin group	Pin#	Pin Name	Type	Description
Supply Voltage	3	GND	GND	Ground
	7	VCC	PWR	Power Supply
Control and Status Pins	1	SYNC_CTR L	I	Synchronizing Procedure Control
	12	LOCK	O	Lock Status
UART	8	RXD0	I	Asynchronous Serial Data Output/Input
	9	TXD0	O	
Input Clock	2	1PPS_IN	I	1PPS Reference Input.
Output Clocks	5	1PPS_OUT	O	1PPSOutput
	6	CLK_OUT	O	10.00MHz Output
Reserve	4,10,11	NC		Reserved

3. Electrical Parameters

Table 2 Electrical Parameters

Parameter	Symbol	Minimum	Typical	Maximum	Units
LVC MOS Input					
High Level Input Voltage	V_{IH}	2.4			V
Low Level Input Voltage	V_{IL}			0.4	V
LVC MOS Output					
High Level Output Voltage	V_{OH}	2.4			V
Low Level Output Voltage	V_{OL}			0.4	V



4. Performance

Table 3 Performance

Item	Parameter	Minimum	Typical	Maximum	Units	Test Condition	
Clock Output	Nominal Frequency	10.00			MHz	Synchronizing with 1PPS reference.	
	Duty Cycle	45	50	55	%	Load 15pF	
	Frequency vs. Temperature	-0.2		+0.2	$\times 10^{-9}$	V _{cc} =3.3V; O _{load} =15pF;T _A varies from -40°C to 70°C, temperature slope less than 2°C per minute.	
	Accuracy	-5		+5	$\times 10^{-12}$	24 hours average value when locked to 1PPS.	
	Short-term Stability	-0.01		+0.01	$\times 10^{-9}$	V _{cc} =3.3V;T _A =25°C; 1s; using PN9000; no EMI/EMC or other interference.	
	Daily Aging	-0.5		+0.5	$\times 10^{-9}$	V _{cc} =3.3V;T _A =25°C.	
	Yearly Aging	-0.03		+0.03	$\times 10^{-6}$		
	Phase Noise			-110	-100	dBc/Hz	10Hz
				-138	-133		100Hz
				-148	-143		1KHz
			-150	-145	10KHz		
			-150	-145	100KHz		
			-150	-150	1MHz		
1 PPS Output	Pulse Width		100		ms		
	Accuracy	-30		+30	ns	Synchronizing with 1PPS reference. Mean is 0, and standard deviation is 30ns. After locking, monitor 24 hours.	
	6 hours holdover	-10		+10	μs	ΔT=±20°C, 6 hours holdover after power up 24hours, re-power up and lock 2 hours with 24 hours. Temperature slope less than 3°C per minute.	



Supply Voltage	Supply Voltage	3.135	3.3	3.465	V	
	Warm Up Current			700	mA	
	Steady Current			350	mA	@25°C
	AC Ripple			50	mVpk-pk	10Hz to 1MHz

5. UART

UART interfaces are used for management and TOD, which has a fixed baud rate (115200) using 1 stop bit and no parity. It is a LVTTTL-compatible port and needs an external translator to work with other signal types (such as RS-232C or RS-485).

Time of Day

A TOD message format can be a GPRMC message or one of a group of other GPS messages or proprietary messages to suit specific causes. Such as a GPRMC message has the format \$GPRMC,122356,A,0000.0000,N,00000.0000,W,0.0.0.0,120508,,A*F6 in which the commas are separators. The message is 62 characters in length (i.e. 62 bytes). No parity bit is used, but each byte has a stop bit. The architecture of the message is shown in Table 4.

Table 4 Architecture of GPRMC message

Elements	Description
\$GPRMC	Message header.
122356	UTC value.
A	Status (A = active, V = void).
0000.0000,N	Latitude, north (fixed to zero).
00000.0000,W	Longitude, west (fixed to zero).
0.0	Speed over ground (fixed to zero).
0.0	Track angle (fixed to zero).
120508	Date (ddmmyy).
A	A = autonomous, D = differential, E = estimated, S = simulation, N = not valid.
*F6	Checksum.

6. Control and Status Pins

CM30 is a clock module which synchronizes the local clock to reference such as 1 PPS retrieving from GPS. CM30 will work normally performing synchronizing algorithm when the SYNC_CTRL pin is driven high. It also could be force to work in free-run or holdover status when the SYNC_CTRL pin is driven low.

The LOCK pin indicates the lock status of CM30. High level indicates the module is locked to external 1PPS reference. When the module never is locked to reference after power up, the status of module is free-run, the LOCK pin outputs low. When the reference is lost, the status of module is holdover, the LOCK pin also output low.



7. Environmental Conditions

Table 5 Environmental Conditions

Parameter	Conditions	
Operating Temperature	-40°C to 70°C	
Storage Temperature	-55°C to 105°C	
Storage Humidity	30%~80%	
ESD Level	Human Body Model, class2: 2000V to 4000V; ANSI/ESDA/JEDEC JS-001-2010.	
	Machine Model, class B: 200V to 400V; ANSI/ESDA/JEDEC JS-001-2010.	
Moisture Sensitivity Level	Not humidity sensitive.	
Vibration	Test Condition: 0.75mm ;acceleration:10g;10Hz~500Hz, one cycle per 30 min, test 2 hour. (3 times for each 3 directions X ,Y , Z), IEC 68-2-06 Test Fc.	
Shock	50g; 11ms; half sine wave (3 times for each 3 directions X,Y, Z),IEC 68-2-27 Test Ea/Severity 50A.	
Relative Humidity	20%~70%	Full Package Storage
Temperature	-10°C~35°C	



8. Typical Application

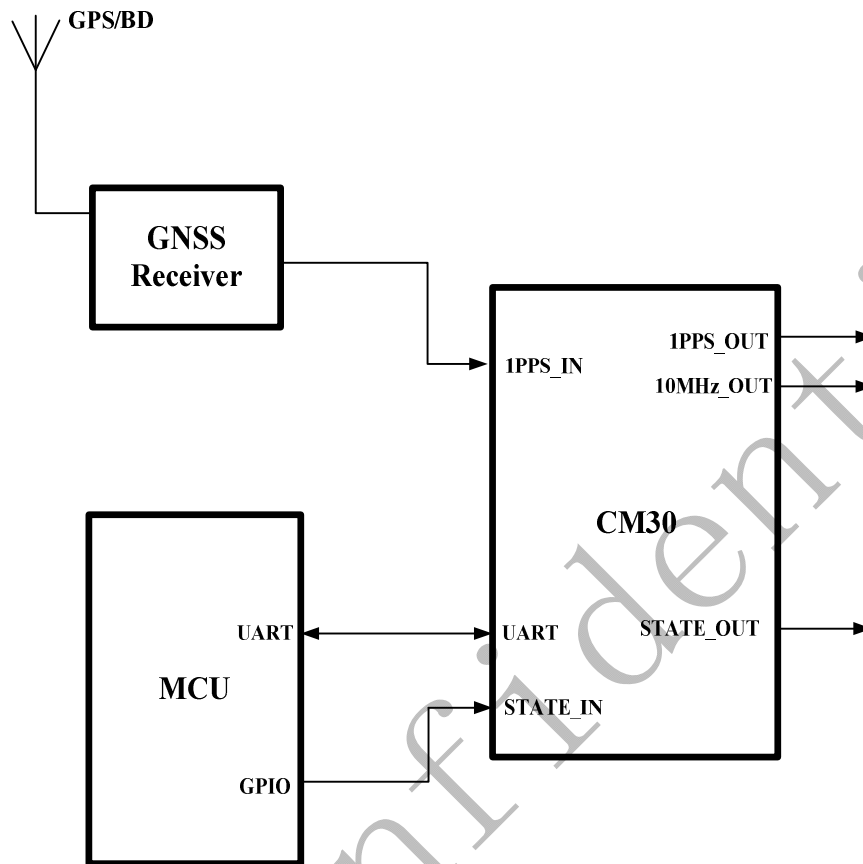

Figure 2 Typical application

GNSS Receiver offers 1PPS signal to CM30.
The MCU monitors the work state of CM30.



9. Mechanical Structure (mm)

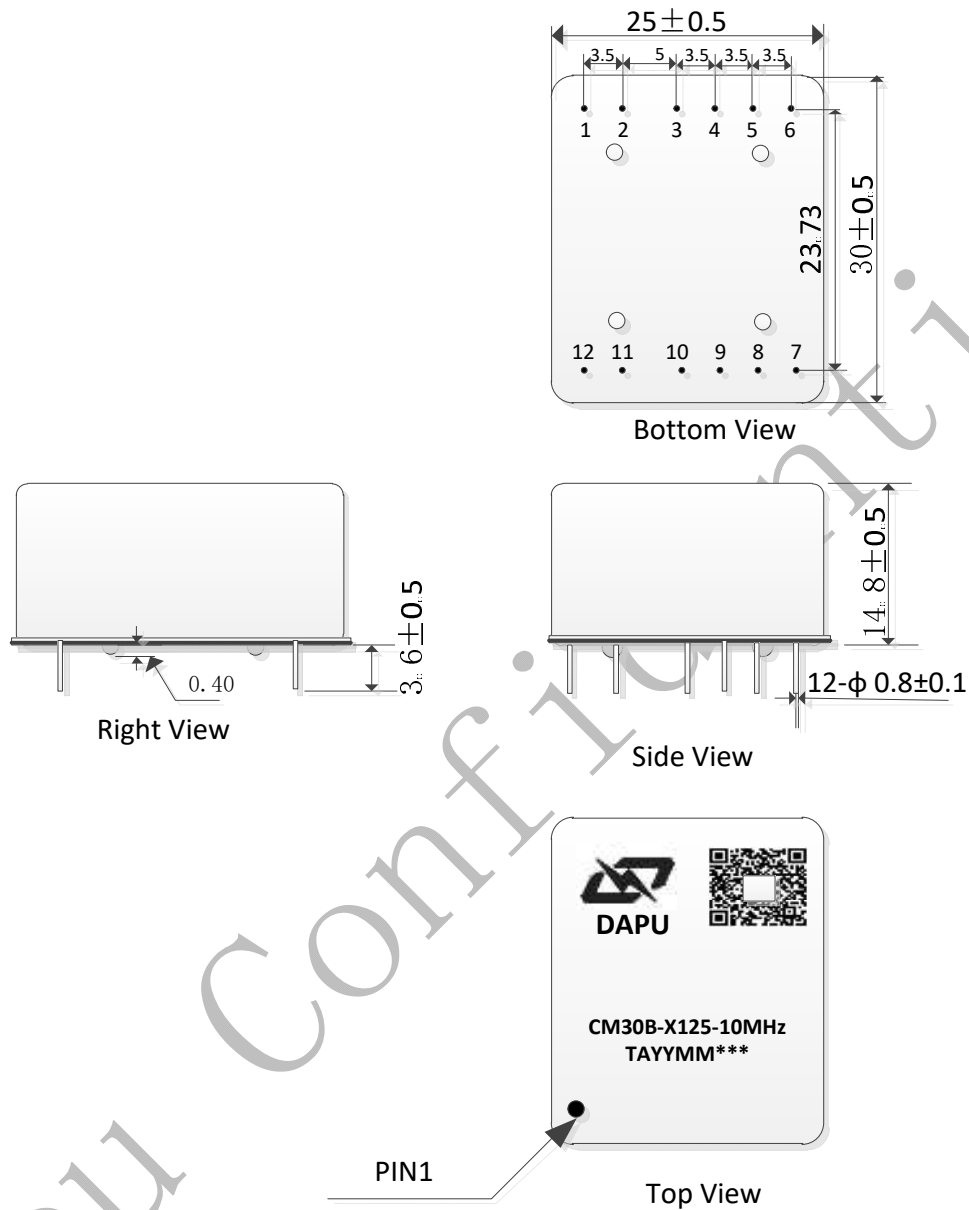

Figure 3 Mechanical structure

Note1: Tolerance ± 0.3 mm without mark.

Note2: WW representative: week.

YY representative: year.



10. Wave Soldering Curve(RoHS)

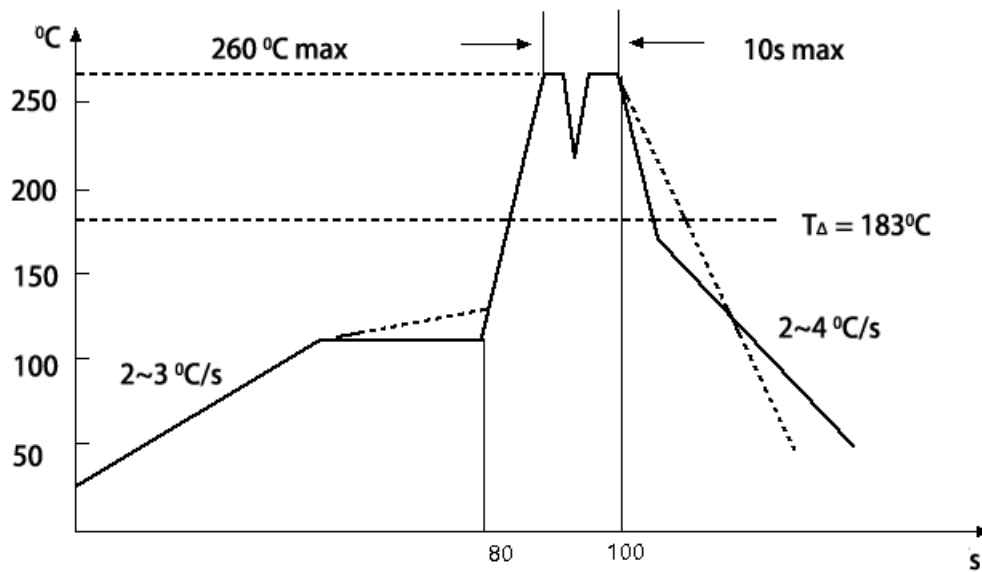

Figure 4 Wave soldering curve

11. Package (mm)

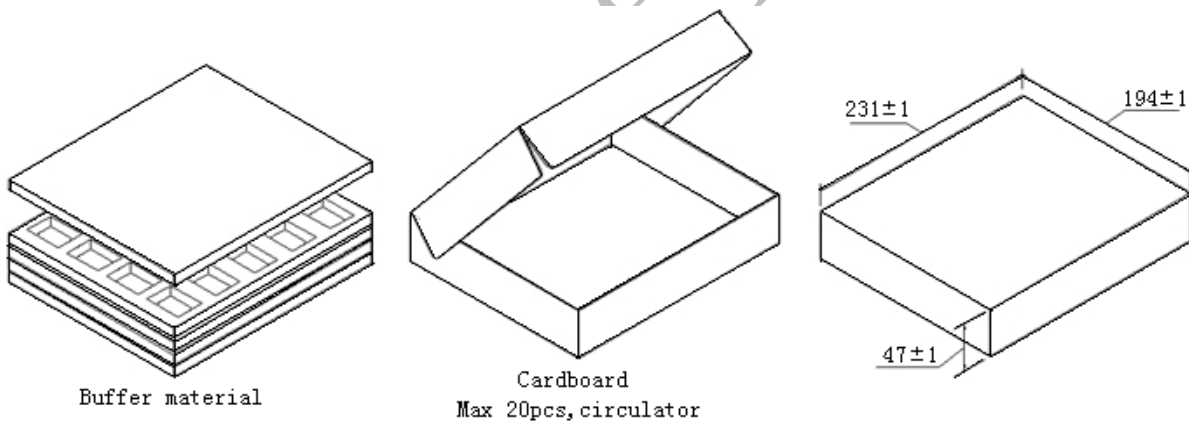

Figure 5 Package