

Travelling Merchant: _____

DATASHEET

Standard: **O23A-R326-10.00MHz**

Plot			The Label
Drew	Audited	Approved	Stamp, please! Thanks!
Date: 2020.06.16			

Guangdong Dapu Telecom Technology Co.,Ltd

Bldg16,.N.Ind.Zone,SSL Industry Park, Dongguan City, Guangdong Province, China

TEL: 0086-0769-88010888 FAX: 0086-0769-81800098



Table of amendment

Version	Revision contents	Prepared by	Revised date
1.1	The first issued	<i>Amway</i>	2010.07.13
1.2	“Current Consumption” changed	<i>Amway</i>	2014.12.23
1.3	“Initial Frequency Tolerance” changed and “Mechanical Structure” changed	<i>Amway</i>	2016.07.28
1.4	The “Mechanical Structure” changed	<i>Amway</i>	2017.04.24
1.5	The “Short-Term Stability: Allan Variance” “Mechanical Structure” changed	<i>Amway</i>	2020.06.16



1、Electrical Parameters

MODEL: O23A-R326-10.00MHz						
Item	Description	Parameters			Unit	Test Condition
		Min.	Typ.	Max.		
Output	Frequency	10.00			MHz	
	Output Waveform	HCMOS				
	Output Low Voltage			+0.4	V	V _{cc} =5.0V, O _{load} =15pF
	Output High Voltage	+3.5			V	V _{cc} =5.0V, O _{load} =15pF
	Duty Cycle	45	50	55	%	@50%
	Rise / Fall Time (10%~90%)			6	ns	@25°C
	Load	15			pF	
Frequency Stabilities	Frequency Tolerance vs. Operating Temperature Range	-0.03		+0.03	ppm	T _A varied from -20°C to70°C, measurement referenced to frequency observed with T _A = 25°C, V _{cc} =5.0V, V _C = 2.5V, O _{load} =15pF , temperature rise speed less than 2°C per minute.
	Initial Frequency Tolerance	-0.05		+0.05	ppm	After warm up 15 minute, Measurement referenced to frequency observed with T _A = 25°C, V _{cc} =5.0V, V _C =2.5V, and after 1 hour of operation.
	Frequency Tolerance vs. Supply Voltage	-5		+5	ppb	measurement referenced to frequency observed T _A =25°C, V _{cc} varied from4.75V to 5.25V, V _C = 2.5V and O _{Load} =15pF.
	Frequency Tolerance vs. Load	-5		+5	ppb	5% load change measurement referenced to frequency observed with T _A = 25°C, V _{cc} =5.0V, V _C =2.5V.
	Short-Term Stability: Allan Variance			0.01	ppb	Temperature stability, no EMI\EMC or other interference, test after power for 1hour ref. to 25°C; 1s.
	Aging Tolerance Per Day	-0.5		+0.5	ppb	V _{cc} , V _C , T _A constant measurement referenced to frequency observed with T _A = 25°C, V _{cc} = 5.0V, V _C =2.5V,and after 30 days of operation.
	Aging Tolerance 1 Year	-0.05		+0.05	ppm	
Power Supply	Supply Voltage	4.75	5	5.25	V	
	Current Consumption			300	mA	@25°C
	Current Consumption during warm up			500	mA	



Voltage Control Characteristics	Frequency Tuning Range			-0.4	ppm	V _C = 0 V. measurement referenced to V _C =2.5V
		-0.05		+0.05	ppm	V _C = 2.5V. measurement referenced to Exactly 10.00MHz
		+0.4			ppm	V _C = 5.0V. measurement referenced to V _C =2.5V
	Linearity			10	%	
	Slope	Positive				
	Input Impedance	100				K Ohm
Phase Noise	Phase Noise		-130		dBc/Hz	100Hz
			-145			1KHz
			-150			10KHz
Environmental Conditions	Operable Temperature	-20		+70	°C	
	Storage Temperature	-40		+85	°C	
	Vibration	Test Condition: 0.75mm ;acceleration:10g;10Hz~500Hz, one cycle per 30 min, test 2 hour. (3 times for each 3 directions X ,Y , Z), IEC 68-2-06 Test Fc.				
	Shock	50g; 11ms; half sine wave (3 times for each 3 directions X ,Y, Z),IEC 68-2-27 Test Ea/Severity 50A.				



2、 Mechanical Structure(mm)

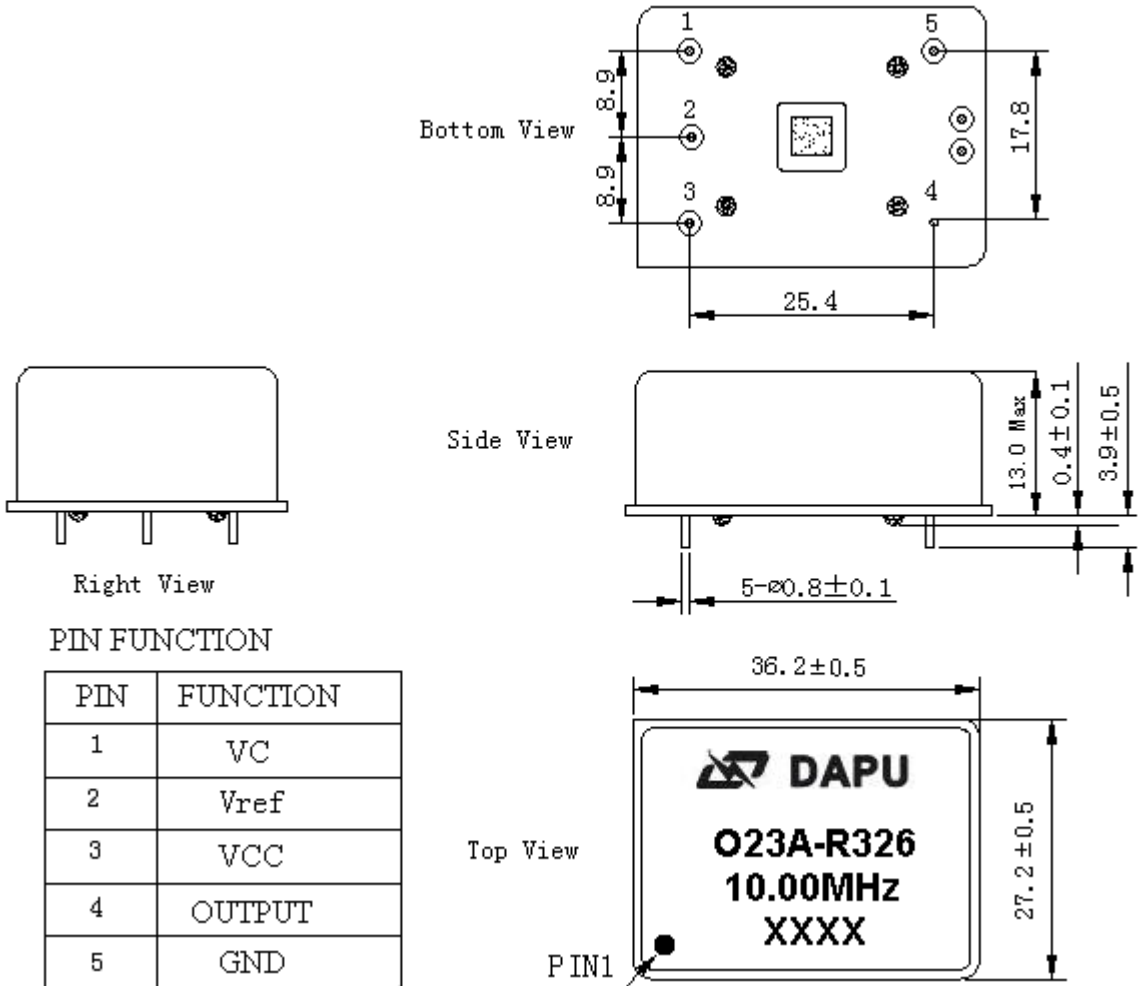

Note1: Referential weight 22.8g

Note2: The first two xx representative: week
After two xx representative: year

Note3: Tolerance ±0.2mm without mark



3、 Test Circuit

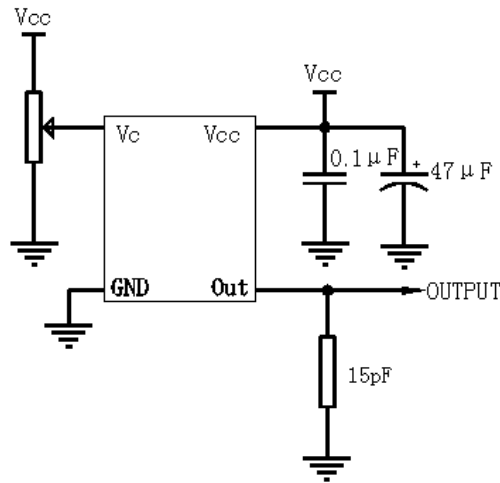

4、 Wave Soldering Curve (RoHS)

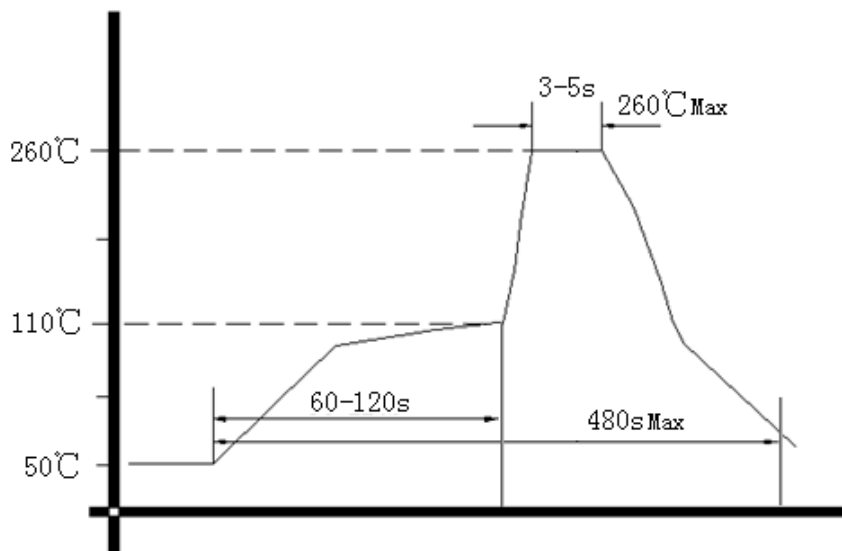

5、 Package (mm)

