

Customer Code : _____

DATASHEET

DAPU P/N: T12A-F426-100.00MHz-B

Customer P/N: _____

DAPU			Customer Approval
Drew	Audited	Approved	Stamp, please! Thanks!
Date: 2020.05.14			

Guangdong Dapu Telecom Technology Co.,Ltd

Bldg13-16,.N.Ind.Zone,SSL Industry Park, Dongguan City, Guangdong Province, China

TEL: 0086-0769-88010888 FAX: 0086-0769-81800098



Table of amendment

Version	Revision contents	Prepared by	Revised date
1.0	The first issued	<i>Amway</i>	2020.03.23
1.1	The "Mechanical Structure" changed	<i>Amway</i>	2020.05.14



1. Electrical Parameters

MODEL: T12A-F426-100.00MHz-B						
Item	Description	Parameters			Unit	Test Condition
		Min.	Typ.	Max.		
Output	Frequency	100.00			MHz	
	Output Waveform	Sine Wave				
	Level	+4	+7		dBm	$V_{cc} = 5.0V, O_{load}=50\Omega.$
	Harmonics Suppression		-30	-25	dBc	$V_{cc} = 5.0V, O_{load}=50\Omega.$
	Spurious Suppression		-85		dBc	
	Load	50			Ω	
Frequency Stabilities	Frequency Tolerance vs. Operating Temperature Range	-0.5		+0.5	$\times 10^{-6}$	T_A varied from $-40^\circ C$ to $85^\circ C$, measurement referenced to frequency observed with $f_{ref}=(f_{max}+f_{min})/2$, $V_{cc}=5.0V, V_c=1.5V$, temperature variable speed less than $2^\circ C$ per minute.
	Initial Frequency Tolerance	-1.0		+1.0	$\times 10^{-6}$	Measurement referenced to frequency observed with $T_A=25^\circ C, V_{cc}=5.0V, V_c=1.5V$, and after 15 minutes of operation, within 30 days after ex-works.
	Frequency Tolerance vs. Supply Voltage	-0.1		+0.1	$\times 10^{-6}$	measurement referenced to frequency observed $T_A=25^\circ C, V_{cc}$ varied from 4.75V to 5.25V, $V_c=1.5V$ and $O_{load}=50\Omega$.
	Frequency Tolerance vs. Load	-0.1		+0.1	$\times 10^{-6}$	5% load change measurement referenced to frequency observed with $T_A=25^\circ C, V_{cc}=5.0V, V_c=1.5V$, and $O_{load}=50\Omega$.
	Aging Tolerance First Year	-1		+1	$\times 10^{-6}$	V_{cc}, V_c, T_A constant measurement referenced to frequency observed with $T_A=25^\circ C, V_{cc}=5.0V, V_c=1.5V$ and after 30 days of operation.
Power Supply	Current Consumption			40	mA	@ $25^\circ C, V_{cc}=5.0V, O_{load}=50\Omega.$
	Supply Voltage	4.75	5.0	5.25	V	



Jitter	Phase Jitter		0.4		ps	12KHz to 20MHz
Voltage Control Characteristics	Frequency Tuning Range			-5	$\times 10^{-6}$	$V_c=0V$. measurement referenced to $V_c=1.5V$
		-1.0		+1.0	$\times 10^{-6}$	$V_c=1.5V$. measurement referenced to exactly 100.00MHz
		+5			$\times 10^{-6}$	$V_c=3.0V$. measurement referenced to $V_c=1.5V$
	Linearity			10	%	
	Slope	Positive				
	Input Impedance	100				K Ω
Phase Noise	Phase Noise		-80		dBc/Hz	10Hz
			-110			100Hz
			-140			1KHz
			-155			10KHz
			-160			100KHz
Environmental Conditions	Operable Temperature	-40		+85	$^{\circ}C$	
	Storage Temperature	-55		+105	$^{\circ}C$	
	ESD Level	Human Body Model, class2: 2000V to 4000V; ANSI/ESDA/JEDEC JS-001-2010.				
		Machine Model, class B: 200V to 400V; JEDEC JESD22-A115C.				
	Moisture Sensitivity Level	Not humidity sensitive.				
	Vibration	Test Condition: 0.75mm ;acceleration:10g;10Hz~2000Hz, one cycle per 30 min, test 2 hour. (3 times for each 3 directions X , Y , Z) .IEC 68-2-06 Test Fc.				
Shock	100g; 6ms; half sine wave (3 times for each 3 directions X , Y , Z),IEC 68-2-27 Test Ea/Severity 50A.					
Full Package Storage	Relative humidity (%)	20% ~ 70%				
	Temperature ($^{\circ}C$)	-10~35 $^{\circ}C$				



2. Mechanical Structure(mm)

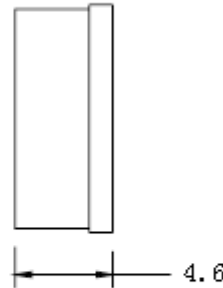
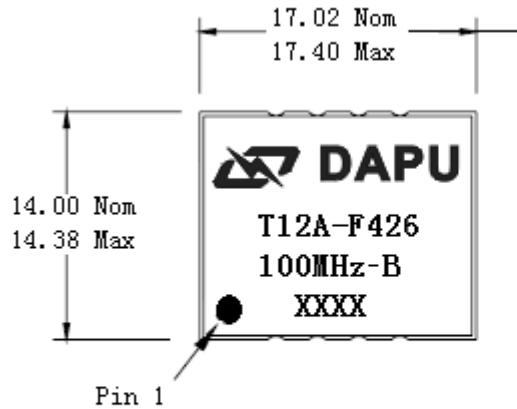

PIN CONNECTIONS

1	Supply Voltage
2	N/C
3	Gnd
4	Gnd
5	Output
6	Voltage Control
7	N/C
8	N/C

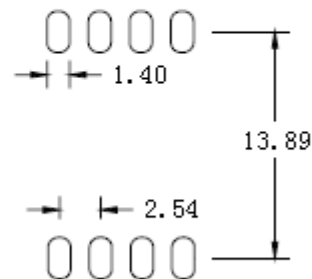
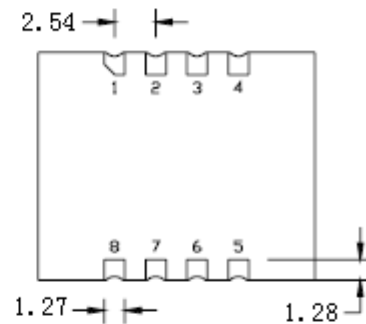

Recommended land pattern based on IPC-7351

- Note1:** Tolerance $\pm 0.20\text{mm}$ without mark
Note2: The first two xx representative: week
 After two xx representative: year



3. Test circuit

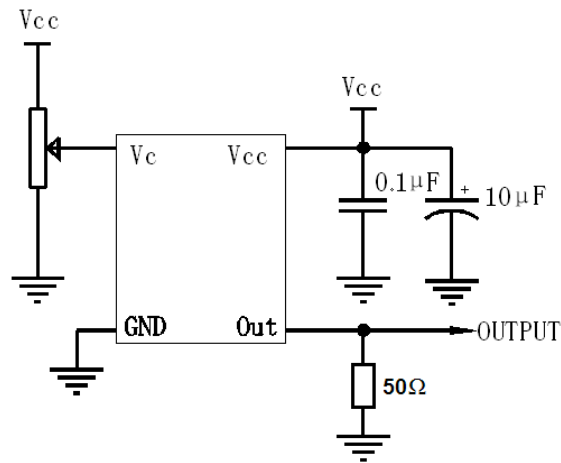

4. Reflow Soldering Curve (RoHS)

