

Travelling Merchant: _____

DATASHEET

Standard: O22B-J329-10.00MHz

P/N: _____

Plot			The Label
Drew	Aud ited	Approve d	Stamp, please! Thanks!
Date : 2018 .08.06			

Guangdong Dapu Telecom Technology Co., Ltd

Bldg13-16,.N.Ind.Zone,SSL Industry Park,DongguanCity, GuangdongProvince, China

TEL: 0086076988010888 FAX: 0086076981800098



1. Electrical Parameters

MODEL: O22B-J329-10.00MHz						
Item	Description	Parameters			Unit	Test Condition
		Min.	Typ.	Max.		
Output	Frequency	10.00			MHz	
	OutputWaveform	LVTTTL				
	OutputLow Voltage			0.4	V	$V_{cc}=5.0V, Q_{load}=15pF$
	OutputHigh Voltage	2.6			V	$V_{cc}=5.0V, Q_{load}=15pF$
	Duty Cycle	45	50	55	%	@50%
	Rise / FallTime (10%~90%)			6	ns	
	Load	15			pF	
	Spurious			-60	dBc	
	Output overshoot			10	%	
Frequency Stabilities	FrequencyTolerance vs. Operating Temperature Range	-0.01		+0.01	$\times 10^{-6}$	T_A varied from $-40^{\circ}C$ to $85^{\circ}C$, measurement referenced to frequency observed with $T_A=$ $25^{\circ}C, V_{cc}=5.0V, Q_{load}=15pF$, temperature rise speed less than $2^{\circ}C$ per minute.
	Initial Frequency Tolerance	-0.1		+0.1	$\times 10^{-6}$	Measurement referenced to frequency observed with $T_A=25^{\circ}C, V_{cc}=5.0V$,
	FrequencyTolerance vs. SupplyVoltage	-1.0		+1.0	$\times 10^{-9}$	measurement referenced to frequency observed $T_A=25^{\circ}C, V_{cc}$ varied from 4.75V to 5.25V and $Q_{load}=15pF$
	FrequencyTolerance vs. Load	-1.0		+1.0	$\times 10^{-9}$	5% loadchangemeasurement referenced to frequency observed with $T_A=25^{\circ}C, V_{cc}=5.0V$ and $Q_{load}=15pF$
	ShortTerm Stability			0.05	$\times 10^{-9}$	After power on one hour and stabilization after power on 30mins, Alan Variance
	Aging Tolerance Per day	-0.5		+0.5	$\times 10^{-9}$	V_{cc}, T_A constant measurement referenced to frequency observed with $T_A=25^{\circ}C, V_{cc}=$ 5.0V, and after 30 days of operation
	Aging Tolerance 1 Year	-0.05		+0.05	$\times 10^{-6}$	
	Aging Tolerance 10Year	-0.3		+0.3	$\times 10^{-6}$	



Power Supply	Supply Voltage	4.75	5.0	5.25	V	
	Steady Consumption			300	mA	@25°C
	Warm up current			600	mA	
	Warm-Up Time			10	minutes	@25°C within $\pm 0.01 \times 10^6$ power on 10 minutes compared with 1 hour
Phase Noise	Phase Noise		-95	-90	dBc/Hz	1Hz
			-125	-120		10Hz
			-140	-135		100Hz
			-148	-145		1KHz
Environmental Conditions	Operable Temperature	-40		+85	°C	
	Storage Temperature	-55		+125	°C	
	Operating Humidity	10		85	%	
	ESD Level	Human Body Model, class 2: 2000V to 4000V; ANSI/ESDA/JEDEC JS-001-2010				
		Machine Model, class B 200V to 400V; ANSI/ESDA/JEDEC JS-001-2010				
	Moisture Sensitivity Level	Not humidity sensitive.				
Vibration	Test Condition: 0.75mm ;acceleration:100Hz~500Hz, one cycle per 30 min, test hour. (3 times for each 3 directions X , Y , Z) IEC 68-2-06 Test Fc.					
Shock	50g; 11ms; half sine wave (3 times for each 3 directions X,Y,Z), IEC 68-2-27 Test Ea/Severity 50A.					
Full Package Storage	Relative humidity (%)	20%~70%				
	Temperature(°C)	-10~35°C				



2. Mechanical Structure (mm)

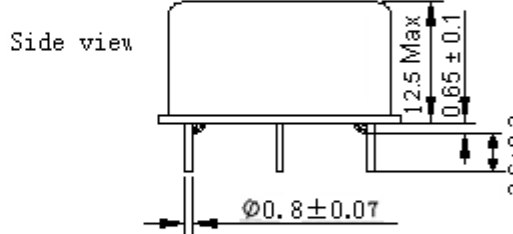
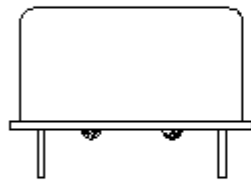
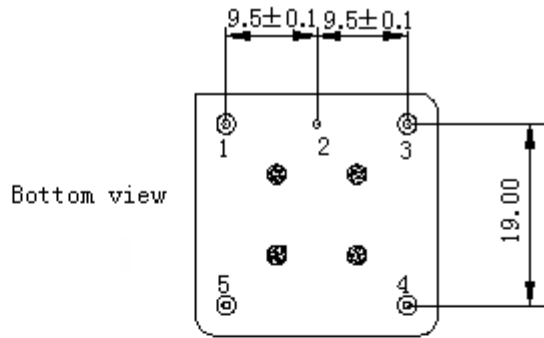

PIN FUNCTION

PIN	NOTATION	FUNCTION
1	OUTPUT	RF Output
2	GND	GND
3	NC	Not Connect
4	NC	Not Connect
5	VCC	Supply Voltage

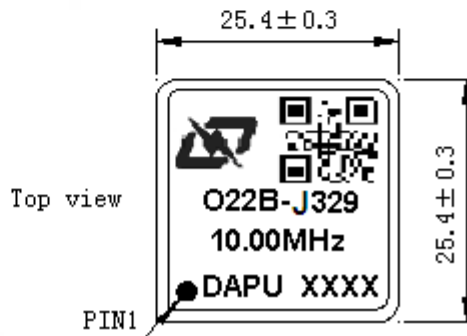

- Note1:** Tolerance± 0.2mm without mark
- Note2:** Referential weight 13.6g
- Note3:** NC is not connect
- Note4:** The first two xx representative: week
After two xx representative: year



3. Test Circuit

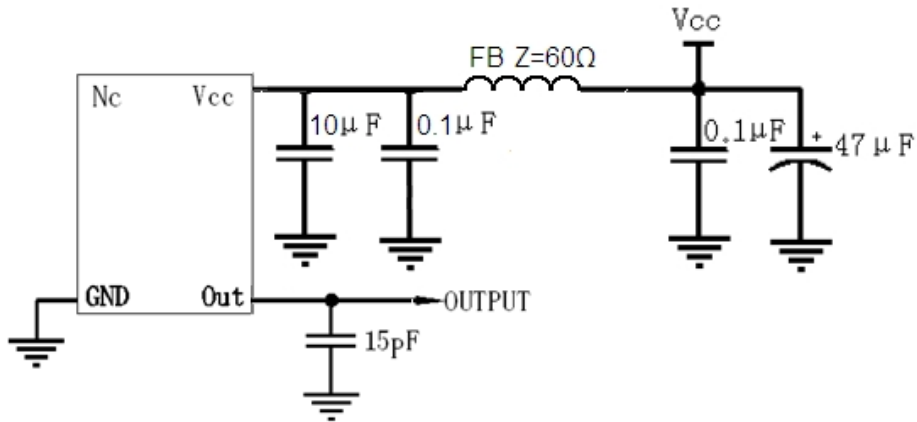

4. Reflow Soldering Curve (RoHS)

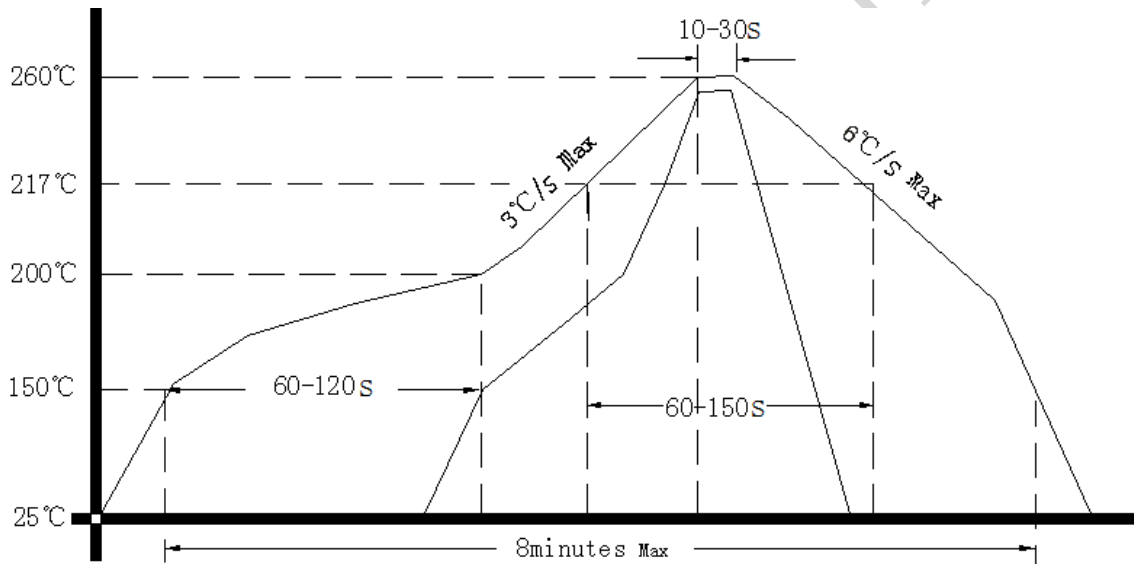

5. Package (mm)

